

Project \_\_\_\_\_

Item \_\_\_\_\_

Quantity \_\_\_\_\_

## PROW-8 Tabletop Proofer



\*Shown with optional 3" casters.  
All external dimensions shown with 3" casters.

### STANDARD FEATURES:

- Stainless steel exterior
- Aluminum interior
- Set of 4" adjustable legs
- Full view tempered glass door
- Silicone rubber door gasket
- AutoMist humidity system

### OPTIONAL FEATURES:

- Warmer
- Set of four casters

### SIZE:

**PROW-8** - 39-3/4" High, 24-1/4" Wide, 31-1/8" Deep  
1010 mm High, 616 mm Wide, 791 mm Deep

NU-VU's PROW-8 tabletop proofer has a stainless steel exterior and tempered glass doors for full view of your product. These units feature the AutoMist humidity system, which eliminates the need for a water pan; however, it does require a 1/4" waterline connection. This feature utilizes a mist, which is sprayed directly onto a fan that distributes the heat and humidity evenly throughout the proofer cavity.

The PROW-8 has a capacity of 8 full size pans and 16 half-size pans.

### CONSTRUCTION:

- Welded stainless steel
- Fully insulated
- Control panel accessible through front of unit
- Heating elements accessible inside of cabinet and through top

### CONTROLS:

- Electromechanical controls
- Indicator light for thermostat
- Separate heat and humidity controls

### LABORATORY CERTIFICATION & APPROVALS:

- C, ETL, US AND NSF

**NU-VU® PROW-8 Tabletop Proofer**

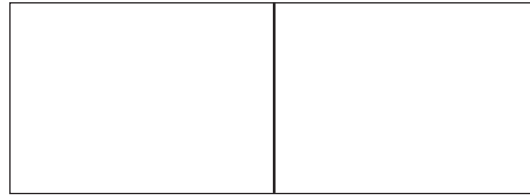

Approval / Stamp

## PROW-8 Tabletop Proofer

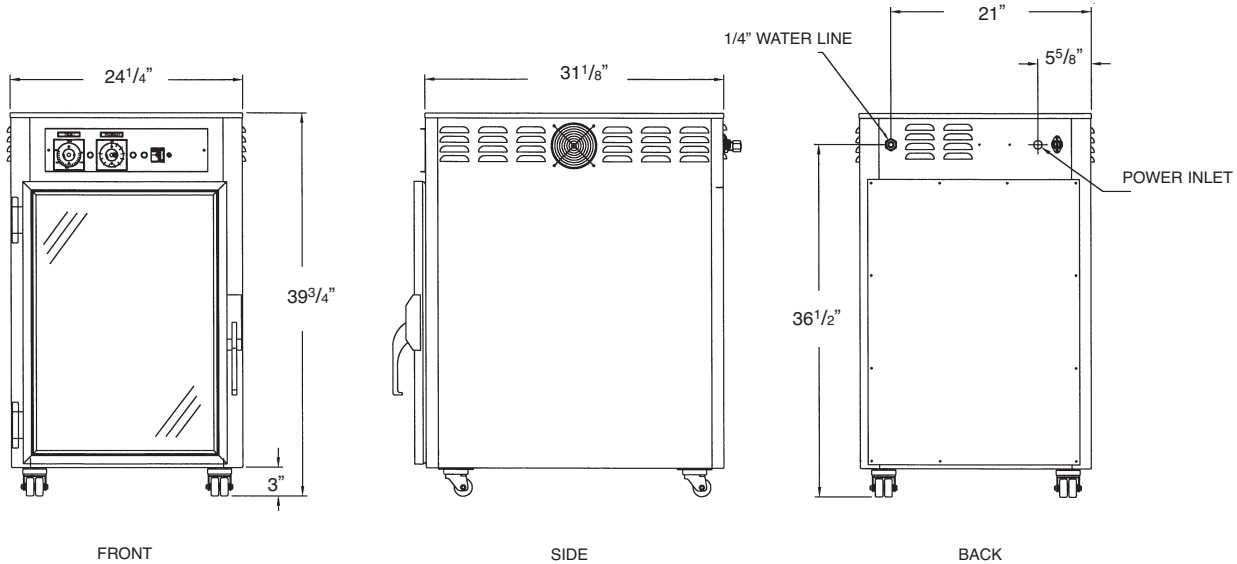

\*Dimensions shown include optional 3" casters.

### SPECIFICATIONS:

#### ELECTRICAL:

#### SERVICE CONNECTIONS:

- Unit is shipped from factory with cord and plug
- A 1/4" water line is required.

#### ELECTRICAL:

Amp Draw	120/1
L1	15
L2	0

#### INSTALLATION:

Allow four inches on each side and back of unit for ventilation of oven.

#### CAPACITY:

	18"x26" Sheet Pans	13"x18" Sheet Pans	Spacing
Proofer	8	16	3-5/16"

#### DIMENSIONS:

	Height	Width	Depth
Exterior	39-3/4"	24-1/4"	31-1/8"
Interior	27-7/8"	18-3/8"	29"

**DOOR SWING:** Proofer - 23-7/8" (606 mm)

#### PACKING SIZE:

45" High, 36" Wide, 36" Deep  
(1143 mm High, 914 mm Wide, 914 mm Deep)

#### SHIPPING WEIGHT:

230 Pounds (104 Kg), FOB Menominee, MI 49858

**NU-VU® PROW-8 Tabletop Proofer**