



# Electrolux

## High Productivity Cooking Touchline tilting pressure braising pan, electric, 24 gal (90 lt)

ITEM # \_\_\_\_\_

MODEL # \_\_\_\_\_

NAME # \_\_\_\_\_

SIS # \_\_\_\_\_

AIA # \_\_\_\_\_



# Electrolux

High Productivity Cooking  
Touchline tilting pressure braising pan, electric, 24 gal (90 lt)



**587021 (PUET09ECUU)** Touchline tilting pressure braising pan, electric, 24gal capacity (90lt) - 208V/3p/60Hz

### Short Form Specification

#### Item No. \_\_\_\_\_

AISI 304 stainless steel construction. GN compliant pan size; 0.7" (18mm) thick pan bottom 0.6" (15mm) mild steel and 0.1" (3 mm) AISI 316 stainless steel. Insulated and counterbalanced lid. Motorized tilting with variable speed control. Pan can be tilted beyond 90° to completely empty the food. Safety thermostat protects the pan from overheating. A precise, electronic control of pan bottom temperature ensures fast reaction and exact adherence to preselected cooking temperatures between 122 and 482°F (50° and 250°C). Automatic steam elimination at the end of the cooking cycle. It can be used for poaching or steaming (with the lid open); simmering and boiling (with open or closed lid). TOUCH control panel. SOFT function. PRESSURE function. IPX6 water resistant. Configuration: Free-standing or Standing against a wall. Installation options (not included): floor mounted on 8" (200mm) high feet or a plinth which can be either steel or masonry construction.



APPROVAL: \_\_\_\_\_

### Main Features

- Multifunctional cooking appliance used for roasting, pot-roasting, braising, simmering, boiling, pressure cooking and steaming.
- Pan size is GN compliant.
- Easy to clean cooking surface due to large-radius edges and corners.
- Thermoblock heating system for optimal temperature distribution and high temperature stability.
- Pan bottom with two individually adjustable heating zones, each with a temperature sensor.
- Safety mechanism prevents lid from opening, even in case of voluntary attempt, when cooking under pressure.
- Temperature sensors provides efficient temperature control: the power is supplied as and when required to keep the set temperature value without exceeding it.
- Safety valve on the lid avoids overpressure in the food compartment.
- Cooking with a working pressure of 6.5psi (0.45 bar) reduces cooking times.
- IPX6 water resistant.
- Optimum heat distribution in the food provides best cooking results in terms of taste, colour and consistency and in terms of vitamin preserving.
- Overnight cooking: saving electricity and time.
- High-quality thermal insulation of the pan saves energy and keeps operating ambient temperature low.
- Motorized, variable pan tilting with "SOFT STOP". Tilting and pouring speeds can be precisely adjusted. Pan can be tilted over 90° to facilitate pouring and cleaning operations.
- "Pressure function": once the pressure lid is locked, the system automatically regulates itself.
- Built in temperature sensor to precisely control the cooking process.
- No overshooting of cooking temperatures, fast reaction.
- USB connection to easily update the software, upload recipes and download HACCP data.

### Construction

- External panelling and internal frame made of 1.4301 (AISI 304) stainless steel.
- Multipurpose non-stick cooking surface in 0.75" (18 mm) thick compound: 0.1" (3 mm) shot-blasted 1.4404 (AISI 316L) stainless steel surface, seamlessly welded to the mild steel bottom.
- Entire pan tub made in 1.4301 (AISI 304) stainless

Electrolux Professional, Inc.

[www.electroluxusa.com/professional](http://www.electroluxusa.com/professional)

10200 David Taylor Drive, Charlotte, NC 28262 • Telephone Number: 866-449-4200 • Fax Number: 704-547-7401



# Electrolux

## High Productivity Cooking Touchline tilting pressure braising pan, electric, 24 gal (90 lt)

steel, single-piece deep drawn.

- Double-lined insulated lid in 1.4301 (AISI 304) stainless steel mounted on the cross beam of the unit, counterbalanced by a hinge that remains open in all positions.
- 0.6" (15 mm) thick heating layer concealed below the entire pan bottom, to provide high thermal diffusion and heat storage properties.
- Water mixing tap is available as optional accessory to make water filling and pan cleaning easier.
- Heatproof handle with non-slip surface.
- Front-mounted inclined led "TOUCH" control panel with recessed deep drawn casing, features self-explanatory display functions which guide operator throughout the cooking process: simultaneous display of actual and set temperature as well as set cooking time and remaining cooking time; real time clock; "SOFT" control for gentle heating up for delicate food; 9 power simmering levels from gentle to heavy boiling; timer for deferred start; error display for quick troubleshooting.
- Pressure lid fitted with a proven fast-acting lock which is simple and safe in operation.
- "Boiling" or "Braising" mode functions.
- Minimised presence of narrow gaps for easier cleaning of the sides to meet the highest hygiene standards.
- Can be prearranged for energy optimisation or external surveillance systems (optional).
- 98% recyclable by weight; packaging material free of toxic substances.

### Optional Accessories

- Dumpling strainer for 21/26 gallon kettles PNC 910053
- Scraper for "dumpling" strainer for kettles PNC 910058
- Suspension frame for Pressurized Tilting Braising Pans - 2 needed for 24 gallon units (587021, 587027) - 3 needed for 45 gallon units (587025, 587028) PNC 910191
- Base plate, for pressure braising pans and non-pressure braising pans, half size - 2 needed for 24 gallon units (587031, 587037, 587021, 587027) - 3 needed for 45 gallon units (587035, 587039, 587025, 587028) PNC 910201
- Perforated container with handles, height 4" (102mm) PNC 910211
- Perforated container with handles, height 6" (152mm) PNC 910212
- Perforated container with handles, height 8" (203mm) PNC 911673
- Left cover plate and mixing faucet for kettle (587040), and all braising pans (587037, 587039, 587031, 587035, 587027, 587028, 587021, and 587025) PNC 911819
- Spray gun for tilting units, height 27-1/2" (698.5mm) - factory fitted PNC 912776

- Integrated HACCP kit PNC 912781
- SCRAPER WITHOUT HANDLE (PFEX/PUEX) PNC 913431
- - NOT TRANSLATED - PNC 913432
- 4 flanged feet, 2", for prothermetic units (kettles, braising pans & pressure braising pans) PNC 913438



# Electrolux

## High Productivity Cooking Touchline tilting pressure braising pan, electric, 24 gal (90 lt)

Front

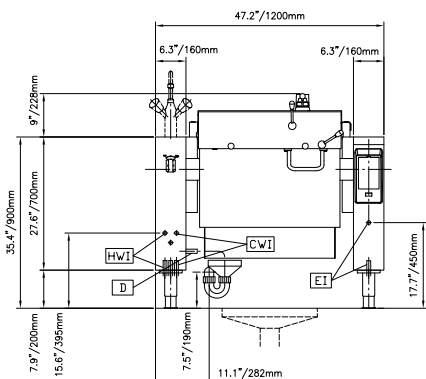

Side

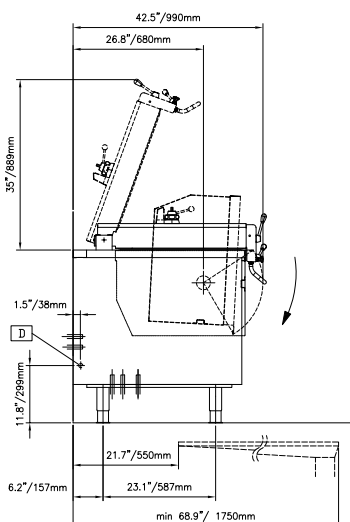

CWII = Cold Water inlet

D = Drain

EI = Electrical connection

Top

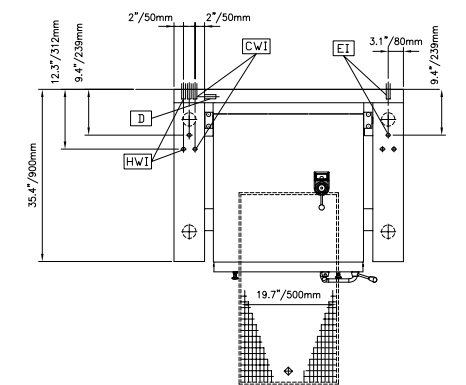

### Electric

Supply voltage:

587021 (PUET09ECUU) 208 V/3 ph/60 Hz

Total Watts:

15.5 kW

### Water:

Pressure:

29-87 psi (2-6 bar)

Drain line size:

1/2"

Incoming Cold/hot Water

line size:

1/2"

### Installation:

FS on concrete base; FS on feet; On base; Standing against wall

Type of installation:

### Key Information:

Configuration:

Rectangular; Tilting

Working Temperature MIN:

122 °F (50 °C)

Working Temperature MAX:

482 °F (250 °C)

External dimensions, Width:

47 1/4" (1200 mm)

External dimensions, Depth:

35 7/16" (900 mm)

External dimensions, Height:

27 9/16" (700 mm)

Net weight:

529 lbs (240 kg)

Shipping width:

51 3/16" (1300 mm)

Shipping depth:

49 3/16" (1250 mm)

Shipping height:

55 1/8" (1400 mm)

Shipping weight:

992 lbs (450 kg)

Shipping volume:

80.33 ft<sup>3</sup> (2.27 m<sup>3</sup>)

Heating type:

Direct

Tilting mechanism:

Automatic

High Productivity Cooking  
Touchline tilting pressure braising pan, electric, 24 gal (90 lt)

The company reserves the right to make modifications to the products  
without prior notice. All information correct at time of printing.

2019.07.19