

# DOUGHPRO™



## The Hydra Dual Heated Press

DP2350SE Dual Heat - Hydraulic Driven - Automatic Dough Press



We've done it again! We recognized a need and did something about it. We designed this dual heated machine to press perfect pizzas in the high paced chain driven environment. We realize the customer must have a consistently pressed product in an incredibly fast paced environment every time. No time to waste! \*NO Compressor required

The DP2350SE concept is based on our patented DP1300 model, which has time tested technology for over 25 years.

### DP2350SE Features:

- Automatic hydraulic driven press with 8" cylinder for more pressure and force than any other press
- 4600 watts to maintain set point temperature
- Dual heat polished aluminum platens upper and lower
- Proluxe Standard Mold.
- Easy two button operation for safety
- Timer and counter function
- Self leveling upper platen
- Embedded cast-in heating elements, backed by our exclusive Proluxe limited lifetime warranty
- No Compressor Required

In addition to the quality execution and unique customization capabilities, our expert technical support team supports the Proluxe DP2350SE. We are available 24 hours a day/7 days a week to answer any questions and provide you with great, no-debate service support.

**PROLUXE** ™

formerly DoughPro. New Name. Same Quality. Superior Service.

[prolux.com](http://prolux.com)



# DOUGHPRO™

## The Hydra Dual Heated Press

DP2350SE Dual Heat - Hydraulic Driven - Automatic Dough Press

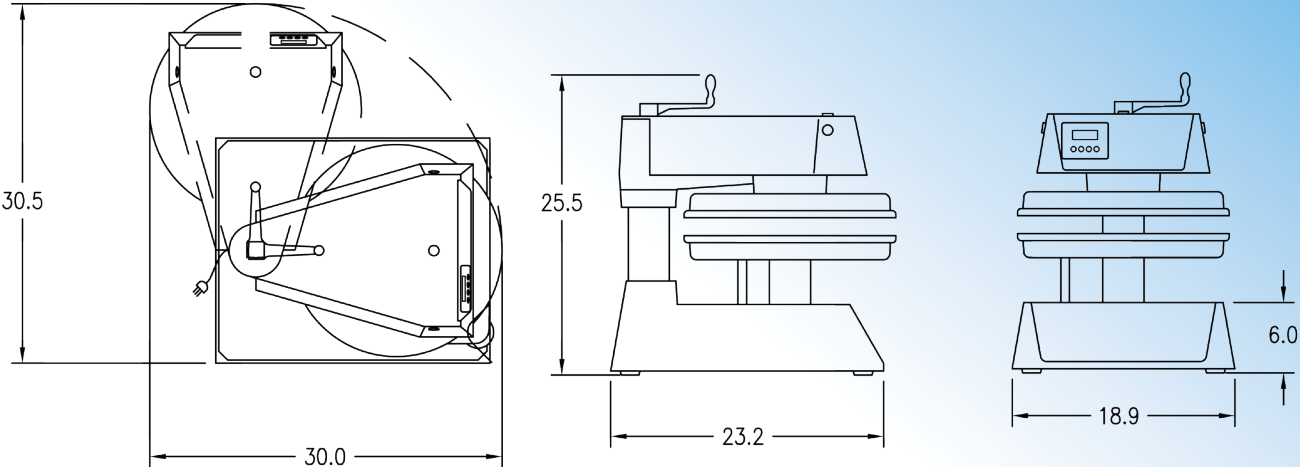

TOP VIEW

LEFT SIDE VIEW

FRONT VIEW

<b>ON/OFF Switch</b>	Yes	<b>Electrical Data</b>  DP2350SE - 208v/50/60hz 4600w/22.1 amps - NEMA 6-30P  Power cord length 72"
<b>Programmable Timer</b>	Yes	
<b>Temperature Control</b>	Yes	
<b>Thickness Adjustment</b>	Based on Mold Size	<b>Shipping Weight</b> 225lbs/102kg  <b>Machine Weight</b> 202lbs/91kg
<b>Maximum Heat</b>	0-450 F	

Listed:



## PROLUXE™

20281 Harvill Ave | Perris, CA 92570  
 t: (951) 657-0379 | t: (800) 624-6717 | f: (951) 657-4594  
 w: www.proluxe.com | e: info@prolux.com