

MODELS:

PPM-20

Heavy Duty 20 Quart Planetary Mixer

Standard Features

- Three fixed speeds
- Gear driven transmission with aluminum alloy gear box
- 30-minute timer
- Safety cut-switch temporarily interrupts power if gears are changed without stopping the mixer
- Easy to reach controls
- Interlocked bowl lift and stainless-steel bowl guard with swing out bowl
- 6' cord with NEMA 5-15 plug
- Steel body with open base



Standard Accessory Package

- Stainless steel bowl
- Aluminum flat beater
- Stainless steel wire whisk
- Aluminum spiral dough hook
- Non-slip rubber feet

Optional Accessories

- Meat grinder for #12 hub
- Slicer/Shredder/Grater for #12 hub



1 YEAR PARTS AND LABOR WARRANTY (US ONLY)



SPECIFICATIONS

Model	HP	Watts (W)	Voltage (V/Hz/Ph)	Amps (A)	Capacity (Quarts)	Exterior Dimensions (inch)	Net Weight (lbs)	Gross Weight (lbs)	Agitator Speed (RPMs)		
									First (low)	Second (intermediate)	Third (high)
PPM-20	1 ^{1/2}	1100	115/60/1	14	20	21 ^{3/4} ×21×32	211	246	106	180	367

PLAN VIEW

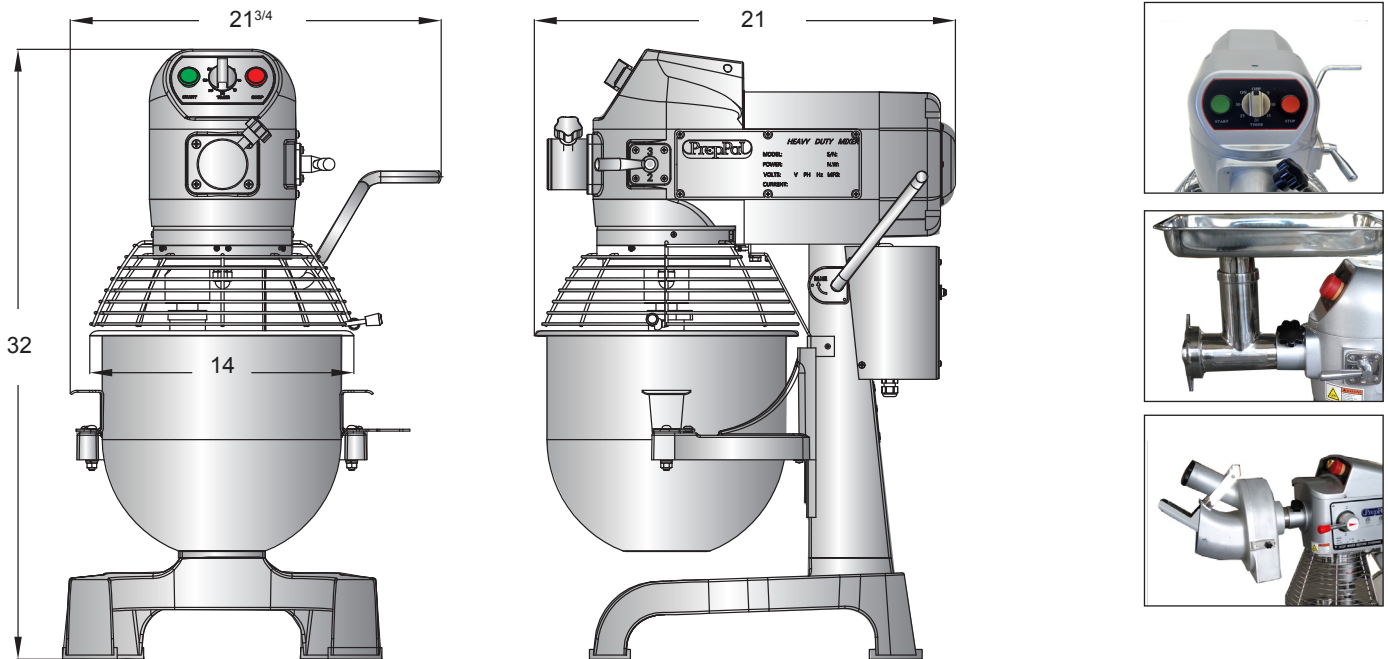

STANDARD ACCESSORY PACKAGE

Mixing Bowl



Dough Hook



Wire whip



Flat beater



NEMA 5-15P



NEMA
15A/125V