

DOUGHPRO™



Simply The Best Dough Press Around

PP1818 Economy Manual Dough Press



If pizza is not your main menu item then this press is designed for you. The ProLuxe PP1818 is simple to use, and super easy to clean. It can create crust equal to hand tossed perfectly every time. Most importantly, this product's ease of use allows anyone to master the art of dough forming. Based on patented technology, the embedded heating element guarantees long-lasting performance.

Features

- Digital control with timer and counter.
- Heated upper platen helps cold dough flow faster.
- Manually operated, no motor or compressors required.
- Flattens all size pizzas up to and including 18" (46 cm) diameter.
- Patented technology
- Heating element is backed by the exclusive ProLuxe limited lifetime warranty.
- Patented base suction prevents press from moving or falling.

In addition to the quality execution and unique customization capabilities, our expert technical support team supports the ProLuxe PP1818. We are available 24 hours a day/7 days a week to answer any questions and provide you with great, no-debate service support.

PROLUXE ™

formerly DoughPro. New Name. Same Quality. Superior Service.

proluxe.com

DOUGHPRO™

Simply The Best Dough Press Around

PP1818 Economy Manual Dough Press

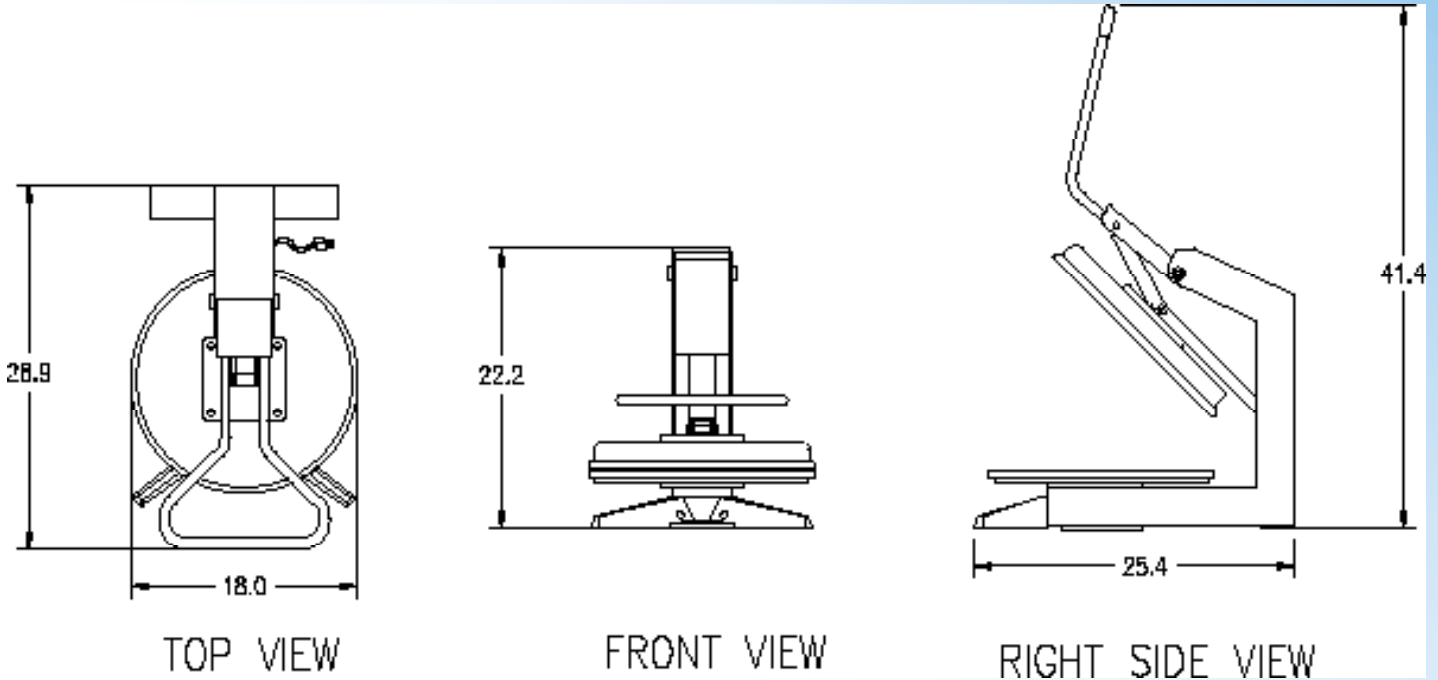

Care and Cleaning-

The use of a mild soapy water solution and a soft sponge to clean the upper and lower platens.

ON/OFF Switch	Yes	Electrical Data PP1818A - 120v/50/60hz 1500w/12.5 amps - NEMA 5-15P PP1818B - 240v/50/60hz 1500w/6.3 amps - NEMA 6-15P
Programmable Timer	Yes	
Temperature Control	Yes	
Thickness Adjustment	No	Shipping Weight 137lbs/62kg Machine Weight 103lbs/46kg
Maximum Heat	0-450 F	

Power cord length 72"

Listed:



PROLUXE™

20281 Harvill Ave | Perris, CA 92570
 t: (951) 657-0379 | t: (800) 624-6717 | f: (951) 657-4594
 w: www.proluxe.com | e: info@prolux.com