

AMERICAN RANGE

QUALITY PROFESSIONAL COOKING EQUIPMENT

AVB-E ECONOMY VERTICAL BROILERS

GAS TYPE: NATURAL LP

STANDARD FEATURES

- Heavy gauge steel frame construction.
- All Stainless Steel front, side and top.
- Compact design for counter installation.
- Sturdy skewers hold up to 70 lb. of product.
- 15" diameter pan at the bottom, slide adjustment front to back.
- Manual valve control for each burner.
- Heavy duty powerful gear motor for smooth and even rotation.
- Front panel located toggle.
- 6 position adjustment of skewer.
- One year limited warranty, parts and labor.



AVB-2E

American Range innovative technology is work in the food service industry. These hand-crafted broilers are engineered with the most advanced features and fabricated to ensure a long demanding life. All welded frame construction and heavy gauge Stainless Steel panels ensure long life and exceptional quality; an all Stainless Steel body makes clean up easy. High efficiency atmospheric infrared burners provide maximum performance at the least possible cost. With three models to choose from, you can select the one most suited to your needs.



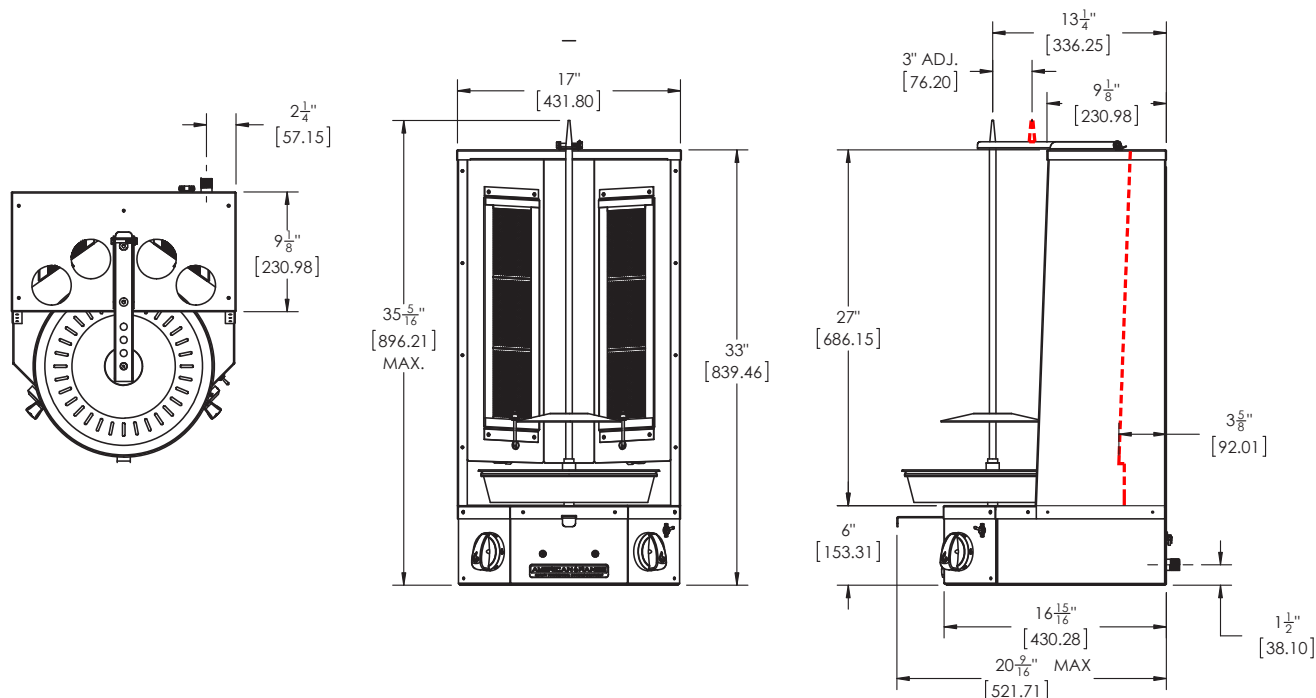

Model	Width	Depth	Height	Burners	Total BTU	KW	Shipping Weight	Lbs.	Kg.
AVB-1E	17"	17"	33"	1	20,000	6		100	45
AVB-2E	17"	17"	33"	2	40,000	12		125	57

STANDARD FEATURES

- Sturdy skewers hold up to 70 lb. of product.
- 15" (381) diameter pan at the bottom, slide adjustment front to back
- High efficiency infrared burners rated @ 20,000 BTU/hr. each (AVB-1E (1), AVB-2E (2))
- Manual valve control for each burner.
- Heavy duty powerful gear motor for smooth and even rotation.
- Toggle switch to turn gear motor on.
- 6 position adjustment of skewer.

GAS SUPPLY AND ELECTRICAL INFORMATION

- Manifold pressure:
5" W.C. - natural gas.
10" W.C. - propane gas.
- When ordering, please specify type of gas and altitude if over 2,000 ft.
- Gas inlet size: 3/4" NPT at bottom.
- A gas pressure regulator is provided and must be installed when the appliance is connected to the gas supply.
- 120 VAC, Single Phase, 60Hz, 15 AMP. 3 prong grounded power cord provided.

GAS SUPPLY:

3/4" NPT Gas inlet. Manifold pressure is 5.0" W.C. for natural gas or 10.0" W.C. for propane gas. Specify type of gas and altitude if over 2000 feet.

CLEARANCES:

Clearance from non-combustible walls is 0". When unit is placed next to combustible walls, clearances must exceed 12" (305) on sides, and 4" (102) from rear.

American Range is a quality manufacturer of commercial cooking equipment because of continuing product improvements these specifications are subject to change without prior notice.