



SPECIFICATION SHEET

Model #:	_____ Qty: _____
Project #:	_____
Consultant:	_____

QUALITY FOOD SERVICE EQUIPMENT

BLENDER STATION



DIMENSIONS

underbar - wall mount

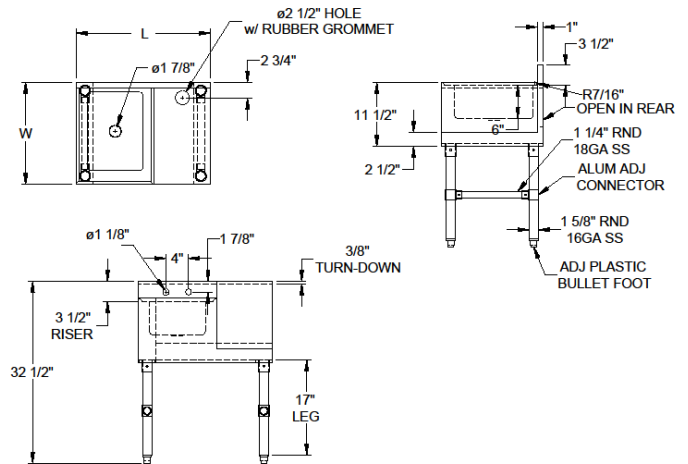

MATERIAL

- ◆ 18GA 300 stainless steel fabricated
- ◆ Stainless steel legs & bracing
- ◆ Plastic bullet feet

FEATURES

- ◆ 4" on center faucet holes
- ◆ 2-1/2" drain hole with rubber grommet
- ◆ Adjustable bullet feet

Model#	Bowl Size LxWxH	Length	Width
UW-1-1014-2418-RH	10"X14"X6"	24"	18-1/4"