



FlamBoyant™ 1400-4PG GAS



DESIGN

- High-performance, elegant, modern rotisserie with interior lighting to accent the beauty of your roasting meats & vegetables
- Porcelain enamel finish in your choice of color
- Stylish metallic valves and switches made of solid chrome
- Chic illuminated "RÔTISSERIE" sign (removable)

CULINARY ADVANTAGES

- Rapid roasting while still retaining traditional rotisserie quality
- 4 adjustable spits, each with its own motor and gas radiant
- State-of-the-art radiants manufactured by ROTISOL
- Separate interchangeable radiants for lower maintenance costs
- Wide variety of cooking accessories (See accessory list.)

SAFETY

- K.GLASS glass doors reduce heat loss, accelerating cooking and preventing burns.
- 2 doors to facilitate access and reduce heat loss (energy saver)
- Heat-proof, ergonomic door handles
- Doorstops control opening & closing and prevent breakage.
- Gas tubes & electric conduits are separated to prevent risk of explosion.

CLEANING

- Removable stainless steel plates between each row of radiants for easy cleaning
- Removable inside panels provide double protection to motors and gas components.
- Drip pan with a drain collects grease drippings for perfect hygiene and accident safety.
- Lighted sign extends out in the front to avoid grease accumulation.

COLOR OPTIONS

STANDARD COLOR	RAL 9005 Glossy Black	RAL 1013 Pearl White	RAL 1015 Ivory	Rose	RAL 3014 Salmon	RAL 1017 Saffron	RAL 1023 Lemon	Pollen	Mustards	Lime	RAL 5003 Sapphire	Aubergine	RAL 7016 Anthracite	TSFW 640/7 Light Copper	Copper
RAL 3020 Scarlett Red	RAL 3013 Tomato Red	RAL 3003 Ruby Red	RAL 3004 Purple Red	RAL 8017 Dark Chocolate	RAL 6011 Almond Green	RAL 6001 Emerald Green	RAL 6002 Olive Green	RAL 6005 Moss Green	NPD 696/61 Glossy Green	RAL 7035 Light Gray	RAL 7037 Dark Gray	Steel	NPD 698/26 Glossy Steel	NPD 698/34 Petrol Blue Gloss	
RAL 2011 Marmalade	Orange	Caramel	RAL 8004 Dark Copper	RAL 8012 Chocolate	Salvia Gray	Iron Blue	Turquoise	Cobalt Blue	RAL 5002 Ultramarine	NPD 698/50 Dark Aubergine	CS 803 Mirror Black	RAL 7021 Charcoal	RAL 9003 White	RAL 9005 Flat Black	

Front view

Rotisserie with roof (optional) and base on casters (optional)

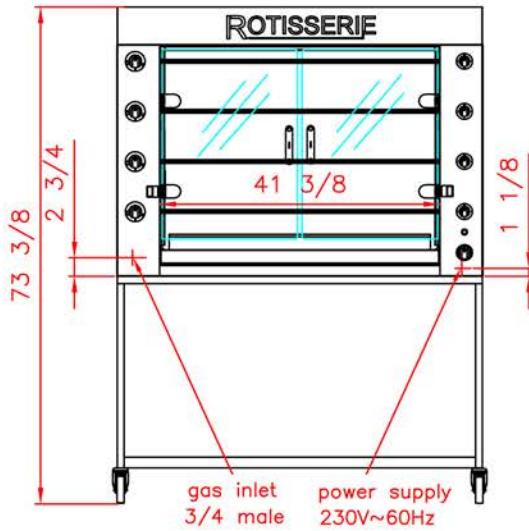

Side view

Rotisserie with roff (optional) and base on casters (optional)

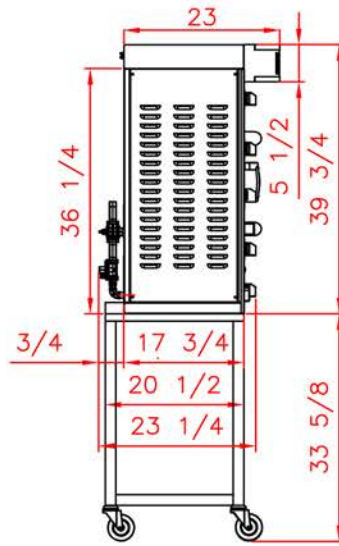

Top view

Rotisserie with roof (optional) and base on casters (optional)

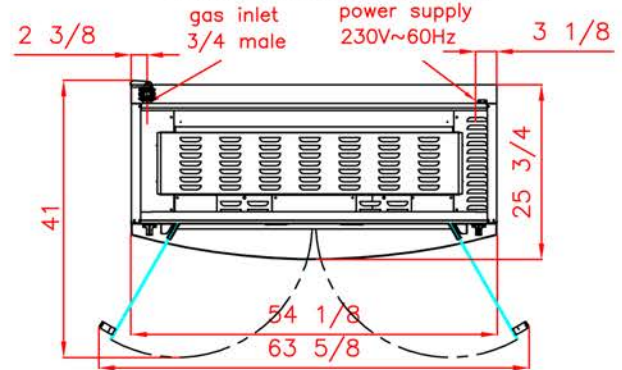

Front view

custom base cabinet (optional)

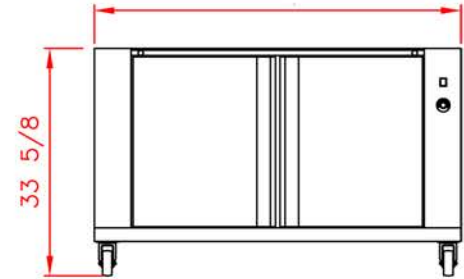

STANDARD FIXTURES

- STD FINISH : Black enamel with all stainless steel trims
- 4 adjustables spit
- Bottom drip pan with drain valve
- 2 Tempered Glass Doors (K.Glass)
- 4 casters with front brakes
- Self-Igniting Pilots
- 4 Individuals Motors
- Roof with Lighted Rotisserie Sign
- 208 / 230 V 60 hertz

SPECIFICATIONS

Gas Power	76000 BTU/hr
Gas minimum pressure	Natural : 7" W.C. minimum ; Propane : 11" W.C.
Gas connector	3/4" male
Electricity	208-230 Volts 60 hertz 1 phase+neutral+earth
Capacity	20/24 poultries
Warranty	1 year parts and labor
Venting	Hood installed conformly with all local codes
Minimum clearance	2 1/2" on the right, left and rear side
Shipping weight	310 LBS

ACCESSORIES

Anti-cutting prongless spit. ref : CUI1400		Lamb/suckling-pig spit. ref : BA1400		Raised rack. ref : GSV1400	
Anti-cutting prongless spit. ref : FIL1400		Vertical spit system. ref : FI1400		Stainless steel tray to unspit. ref : PID1400	
Chicken spit. ref : BP1400		Roast clamp spit. ref : BRRO1400		Spit mover. ref : DEC	
Sabre spit. ref : BS1400		Basket spit. ref : BRC1400		Gas lighter. ref : AT	

Chicken

Turkey

Lamb

Pork

Fish

Beef

Potatoes

