

CONNERTON

American Engineering Since 1936

CNCE SERIES SINGLE DECK ELECTRIC CONVECTION OVENS

Date:

Product:

Quantity:

Single section, Electric convection oven. Stainless steel front, sides and top. Painted legs. Independently operated stainless steel doors with double pane windows. Non-sag insulation applied to the top, rear, sides, bottom and doors. Porcelain enamel on steel oven interior measures 29" w x 22" x 20" h. Two interior oven lights. Five nickel plated oven racks measure 28" x 21". Eleven position nickel plated rack guides with positive rack stops. Furnished with a two speed 1/2 * H.P. oven blower-motor. Oven cool switch for rapid cool down. Heated by electric solid sheath elements rated at 10 KW. Electric options of 208 or 240 volt, 60 Hz, 1 or 3 phase.



Standard Features

- Stainless steel front, sides and top.
- Painted legs.
- Independently operated stainless steel doors with double pane windows.
- 10 Total KW
- 1/2 H.P. two speed oven blower-motor.
- Oven cool switch for rapid cool down.
- Porcelain enamel on steel oven interior.
- Five nickel plated oven racks with eleven rack positions.
- One year limited parts and labor warranty.



Intertek

CNCE

Solid state temperature controls adjust from 150° to 500°F. 60 minute timer with audible alarm.

CNCED

Computer controls with digital time and temperature readouts. 99-hour timer with audible alarm. Roast and Hold cycle. One hundred programmable menu selections.

CONNERTON

11990 Rivera Rd, Santa Fe Springs, CA 90670

Telephone: (562) 464-9901, (714) 547-9218

Fax: (714) 547-1969

connertoncooking.com

CNCE SERIES · SINGLE DECK ELECTRIC CONVECTION OVEN

Accessories

- Stainless steel open stand with adjustable rack supports, stainless steel shelf and choice of adjustable feet or casters.
- Extra oven rack(s).
- Rack hanger.
- Stainless steel drip pan.

Options

- Complete prison package.
- Security screws only.
- Stainless steel legs.
- Casters.
- Second year extended limited parts and labor warranty

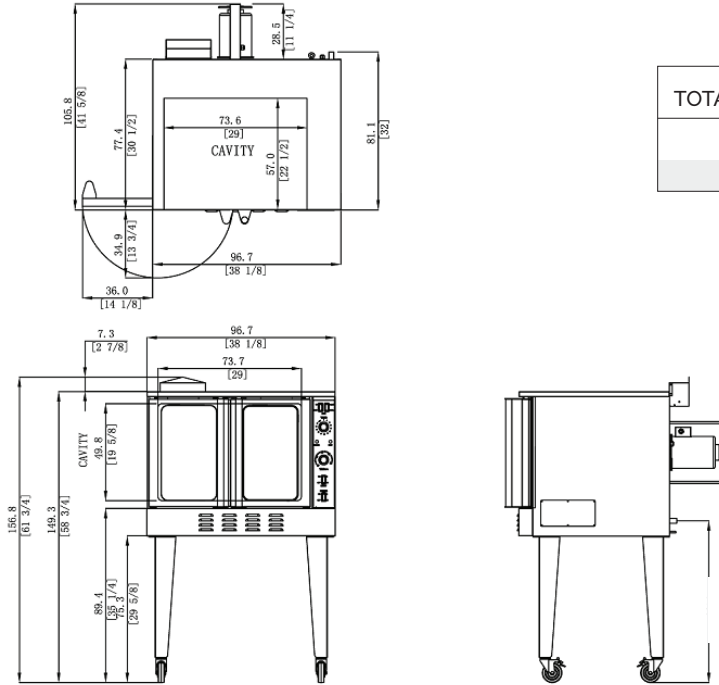

TOTAL HEAT POWER	VOLTAGE	1 PHASE	3 PHASE
10kW	208V	53A	31A
10kW	240V	46A	27A

Product Specifications:

<p>MODEL NO CNCE</p>	<p>WIDTH 38-1/8</p>	<p>DEPTH 41-5/8</p>	<p>HEIGHT 61-3/4</p>
<p>TOTAL 10 KW</p>	<p>ELECTRICAL 120/60/1</p>	<p>WEIGHT WITH SKID & PACKAGING 480/LBS. 218/KG</p>	<p>WEIGHT WITHOUT SKID & PACKAGING 427/LBS. 194/KG</p>

Connerton reserves the right, without notice, to make changes and revisions in product specifications, materials and design, which in our opinion will provide better performance, durability and efficiency.

CONNERTON

11990 Rivera Rd, Santa Fe Springs, CA 90670

Telephone: (562) 464-9901, (714) 547-9218

Fax: (714) 547-1969

connertoncooking.com