



Project \_\_\_\_\_  
 AIA # \_\_\_\_\_ SIS # \_\_\_\_\_  
 Item # \_\_\_\_\_ Quantity \_\_\_\_\_ C.S.I. Section 114000

## G-SERIES - R290

### 1-Section Refrigerator Reach-In Self-Contained Solid Door(s)



#### STANDARD PRODUCT FEATURES

- High Performance, Energy Efficient Refrigeration System
- Reliable Microprocessor Control With LED Temperature Display
- Evaporator Coil Outside Food Zone Provides More Usable Space
- Load-Sure Guard Prevents Problems From Improper Loading
- Durable All-Metal Construction
- Stainless Steel Front & Doors, Anodized Aluminum Sides & Interior
- Full or Half Height Door Models with a Variety of Hinging Configurations
- Long Life EZ-Clean Door Gaskets
- Three (3) Epoxy Coated Shelves Per Section (factory installed)
- Easy to Maintain Front Facing Condenser Coil
- 6" High Locking Casters

#### FIELD INSTALLED ACCESSORIES & OPTIONS

- Trayslides for 18" x 26" Sheet Pans
- Trayslides for 12" x 20" Food Pans
- Trayslides for 14" x 18" Sheet Pans
- Trayslides for 18" x 26", 12" x 20" & 14" x 18" Pans
- Additional Shelves
- Set of (4) 4 1/8" Casters in Lieu of Standard
- 6" High Legs



Intertek



This unit is listed to the applicable ETL, CSA and NSF Standards by an approved NRTL. Consult the factory or unit's data plate for approval information.

#### AVAILABLE CONFIGURATIONS

##### Half-Height Door Models

G10000-032  
G10001-032

##### Hinging

Right  
Left

##### Full-Height Door Models

G10010-032  
G10011-032

##### Hinging

Right  
Left

**\*Please refer to the G-Series Accessory Kit Guide for precise details. (Form TR35872)**

**-GUARANTEED FOR LIFE CAM-LIFT HINGES**

**-GUARANTEED FOR LIFE HORIZONTAL WORKFLOW DOOR HANDLES (SOLID DOORS ONLY)**

Approved by \_\_\_\_\_ Date \_\_\_\_\_ Approved by \_\_\_\_\_ Date \_\_\_\_\_

## MODELS

Half Height Door Models: G10000-032, G10001-032

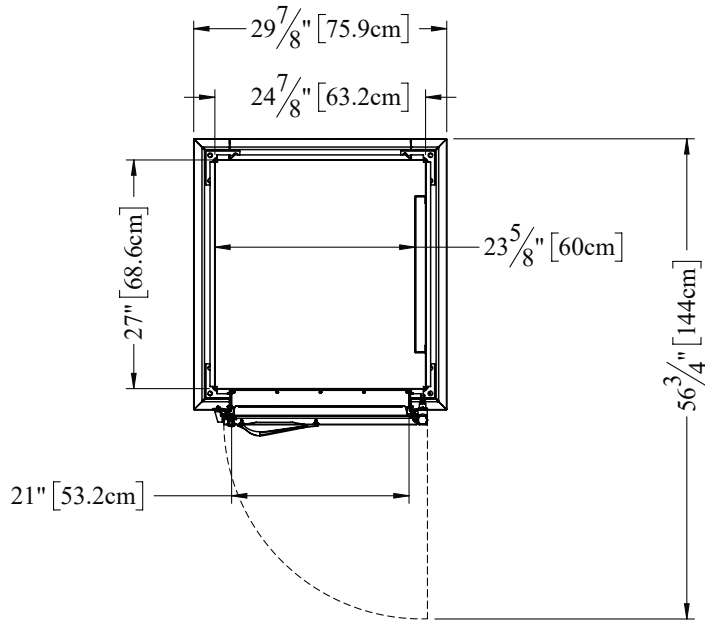

TOP VIEW

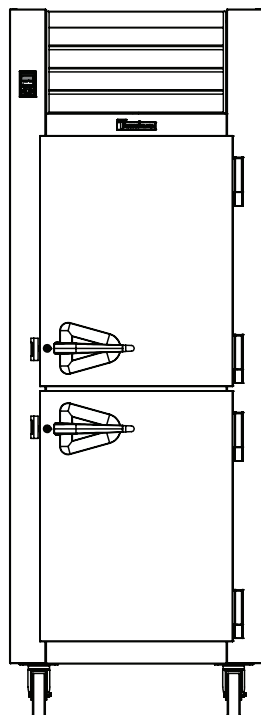

ELEVATION

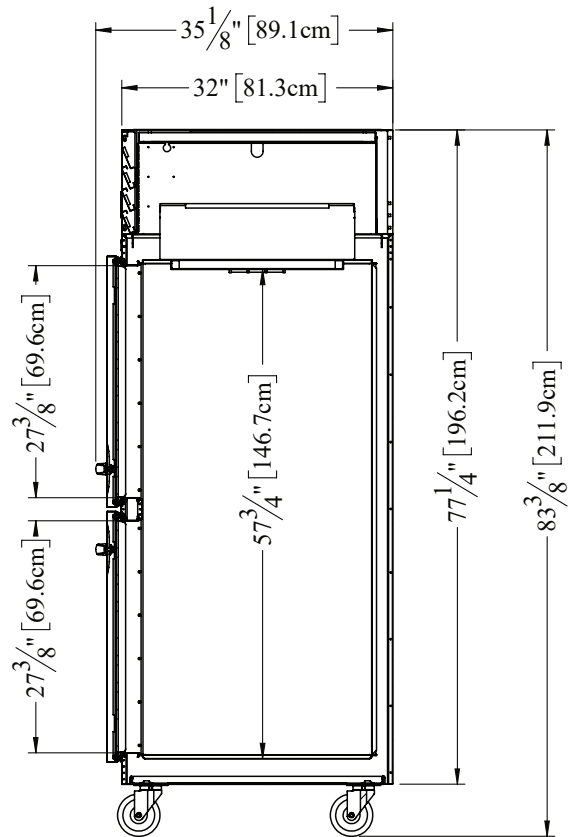

SIDE VIEW

# G-SERIES - R290

## 1-Section Refrigerator Reach-In Self-Contained Solid Door(s)

### MODELS

Full Height Door Models: G10010-032, G10011-032

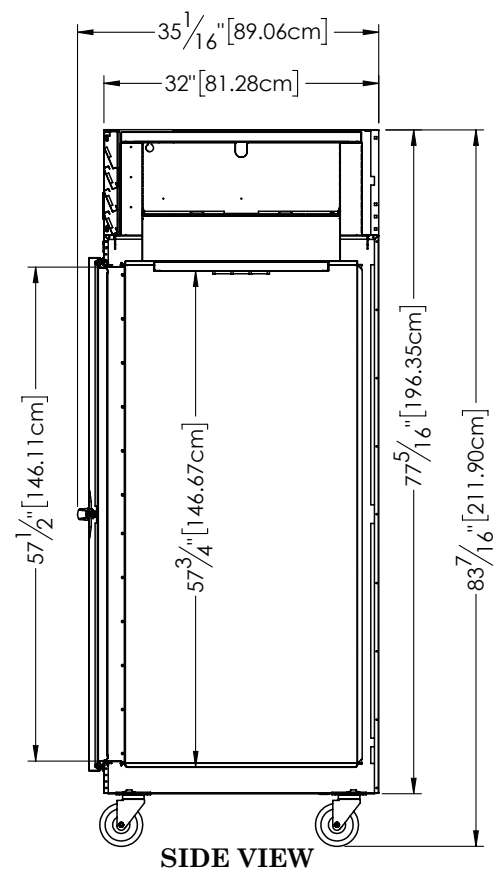
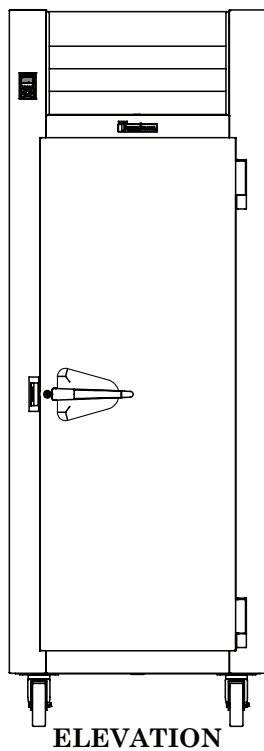
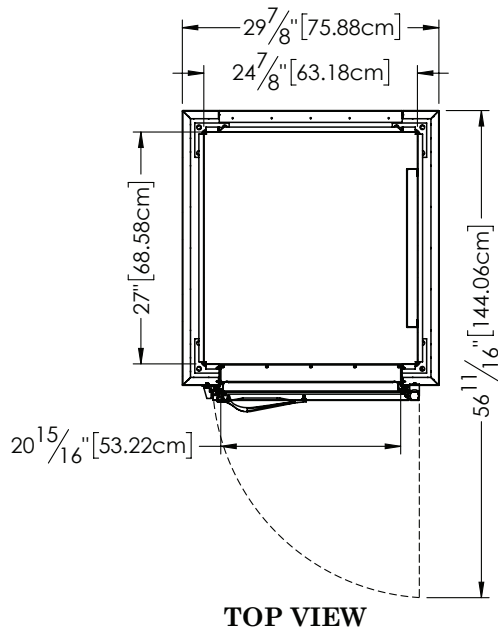



# G-SERIES - R290

## 1-Section Refrigerator Reach-In Self-Contained Solid Door(s)

### MODELS

Half Height Door Models: G10000-032, G10001-032

Full Height Door Models: G10010-032, G10011-032

### EQUIPMENT SPECIFICATIONS

| MODELS                                | G100__-032  |
|---------------------------------------|---|
| <b>DIMENSIONAL DATA</b>               |   |
| Net Capacity cu. ft. <sup>1</sup>     | 23.37 (661.8 l)   23.43 (663.5 l)   |
| L x D x H - Overall in. <sup>2</sup>  | 29 <sup>7</sup> / <sub>8</sub> (75.9 cm) x 35 <sup>1</sup> / <sub>8</sub> (89.1 cm) x 83 <sup>7</sup> / <sub>8</sub> (211.9 cm) |
| Depth - over body in.                 | 32 (81.3 cm)  |
| Depth - door open 90° in.             | 56 <sup>1</sup> / <sub>8</sub> (144.1 cm)   |
| Clear half-door W x H in.             | 21 (53.2 cm) x 27 <sup>3</sup> / <sub>8</sub> (69.6 cm)   |
| Clear full-door W x H in.             | 21 (53.2 cm) x 57 <sup>1</sup> / <sub>2</sub> (146.1 cm)  |
| No. Standard Shelves                  | 3   |
| Shelf Area sq. ft. <sup>3</sup>       | 18.8 (1.75 sq m)  |
| <b>ELECTRICAL DATA</b>                |   |
| Voltage   Plug                        | 115/60/1   NEMA 5-15P (attached)  |
| Feed wires with ground                | 3   |
| Full Load Amperes   MDEC <sup>4</sup> | 3.8   1.54 kWh/Day  |
| <b>REFRIGERATION DATA</b>             |   |
| Refrigerant                           | R-290   |
| Refrigerant Charge Amt. oz.           | 4.5 (127.6 g)   |
| BTU/HR   H.P. <sup>5</sup>            | 1620   1/4 HP   |
| Required Clearance                    | 12" Above   |
| <b>SHIPPING DATA</b>                  |   |
| L x D x H Crated in.                  | 48 (122 cm) x 42 (107 cm) x 85 (216cm)  |
| Volume Crated cu. ft.                 | 99 (2803 l)   |
| Uncrated   Crated Weight lbs.         | 305 (138 kg)   350 (150 kg)   |

#### NOTES:

1. Net Capacity cu. ft. = Half Height Door | Full Height Door models.
2. Height shown when mounted on standard 6" high casters.
3. Figure shown reflects the area of standard shelf compliment.
4. MDEC = Maximum Daily Energy Consumption
5. Based on a 90°F ambient and 20°F evaporator.

#### CONSTRUCTION, HARDWARE, INSULATION

Cabinet exterior front, louver assembly and door(s) are constructed of heavy gauge stainless steel. Cabinet sides (including returns), interior and door liners are constructed of anodized aluminum. The exterior cabinet top, back and bottom are constructed of heavy gauge galvanized steel. A set of four (4) 6" high locking casters are included.

Doors are equipped with a gasket protecting, raised metal door pan, cylinder locks, and guaranteed for life self-closing cam-lift hinges with a stay open feature at 120 degrees. Hinges include a concealed switch to automatically activate the interior LED lighting. Guaranteed for life, metal work flow door handles are mounted horizontally over recess in door which limits protrusion into aisle ways.

Gasket profile and durable long life material simplify cleaning and increase overall gasket life. Anti-condensate heaters are located behind each door opening.

Both the cabinet and door(s) are insulated with an average of 2" thick high density, non-CFC, 100% foamed in place polyurethane.

#### SELF-CONTAINED REFRIGERATION SYSTEM

A top mounted, self-contained, balanced refrigeration system using environmentally friendly R-290 refrigerant is conveniently located behind the one piece louver assembly. It features an easy to clean front facing condenser, thermostatic expansion valve metering device, air-cooled hermetic compressor, large, high humidity evaporator coil located outside the food zone and a top mounted non-electric condensate evaporator. A 9' cord and plug is provided. Standard operating temperature is 34 to 38°F.

#### CONTROL

The easy to use water resistant microprocessor control is supplied standard. It includes a 3-Digit LED Display, and a Fahrenheit or Celsius Temperature Scale Display Capability.

#### INTERIOR ARRANGEMENTS

Standard interior arrangements include three (3) epoxy coated steel wire shelves, mounted on shelf pins, installed at the factory. Recommended load limit per shelf should not exceed 225 lbs.

#### DOMESTIC WARRANTY

Both a six year parts and labor warranty and an additional one year compressor parts warranty (for a total of seven on self-contained models) are provided standard.

When ordering please specify: Voltage, Hinging, and Options.

Equipped with one NEMA 5-15P Plug



| OPTIONAL ACCESSORY TRAYSLIDE VERSATILITY CHART |  |  |  |  |  |   |
|--|--|--|--|--|--|---|
| TRAYSLIDE DRAWINGS                             |  |  |  |  |  |   |
| TRAYSLIDE OFFERING                             | #1<br>(1) 18" x26" or (2) 14"x18"  | #4 (Rod Type)<br>(1) 18" x26"  | Universal<br>(1) 18" x26" or (2) 14"x18"<br>or (2) 12"x20"   | #1 EZ-Change<br>(1) 18" x26" or (2) 14"x18"                        | Universal EZ-Change<br>(1) 18" x26" or (2) 14"x18"<br>or (2) 12"x20"       | HD Universal EZ-Change<br>(1) 18" x26" or (2) 14"x18"<br>or (2) 12"x20" |
| SPACING CAPACITY DOOR SIZE                     | 2" 28 Pairs Full Door & 13 Half<br>3" 19 Pairs Full Door & 09 Half<br>4" 14 Pairs Full Door & 07 Half<br>5" 11 Pairs Full Door & 05 Half | 1 1/2" 38 Pairs Full Door<br>(2 Pair)<br>1 1/2" 18 Pairs Half Door<br>(1 Pair) | 4" 14 Pairs Full Door & 06 Half <sup>1</sup><br>4" 14 Pairs Full Door & 07 Half <sup>2</sup><br>5" 11 Pairs Full Door & 05 Half<br>6" 09 Pairs Full Door & 04 Half | 2" 26 Pairs Full Door & 12 Half<br>4" 13 Pairs Full Door & 06 Half | 2 1/4" 22 Pairs Full Door & 11 Half<br>4 1/2" 11 Pairs Full Door & 05 Half | 4 1/2" 11 Pairs Full Door & 05 Half<br>9" 05 Pairs Full Door & 02 Half  |

- Upper Half Height Door<sup>1</sup>
- Lower Half Height Door<sup>2</sup>

CONTINUED PRODUCT DEVELOPMENT MAY NECESSITATE SPECIFICATION CHANGES WITHOUT NOTICE.