



Project \_\_\_\_\_  
 AIA # \_\_\_\_\_ SIS # \_\_\_\_\_  
 Item # \_\_\_\_\_ Quantity \_\_\_\_\_ C.S.I. Section 114000

## R-Series

Roll-In Freezer Model for 72" High Racks  
 32" Deep, Self-Contained



### STANDARD PRODUCT FEATURES

- Traulsen's Smart Control with LED Display
- StayClear™ Condenser Coil
- Stainless Steel Exterior & Interior
- Balanced, Self-Contained Refrigeration System Using R-448A
- Full-Height Stainless Steel Door with Lock
- Anti-Condensate Door Perimeter Heater
- Self-Closing Door with Stay Open Feature at 120 Degrees
- Standard Door Hinging: 132H = Right (other hings available)
- Automatically Activated LED Lights
- Stainless Steel Breaker Caps
- Accommodates Roll-In Racks Up to 72" High (provided by others)
- Automatic Non-Electric Condensate Evaporator
- Magnetic Snap-In EZ-Clean Door Gasket
- Thermostatic Expansion Valve Metering Device
- Stainless Steel One-Piece Louver Assembly
- Stainless Steel Interior Rack Guides & Threshold Ramp
- 9' Cord & Plug Attached

### ACCESSORIES & OPTIONS

- Stainless Steel Finished Back with Rear Louvers
- Coated Wire Shelf Package (includes 3 shelves per section)
- Additional Coated Wire Shelves for Above
- Rehinging Feature (consult factory)
- Stainless Steel Shelf Package (includes 3 shelves per section)
- Additional Stainless Steel Shelves for Above
- Stainless Steel Banking Strip
- Locking Hasps (padlocks supplied by others)
- Export 220/50/1 Voltage
- Kool Klad Exterior Laminate Decor
- Water Cooled Self-Contained Condenser Suitable for Connection to Glycol
- Heat Shield
- Recessed Installation
- Prison/Correctional Facility Options



Intertek



This unit is listed to the applicable UL, CSA and NSF Standards by an approved NRTL. Consult the factory or unit's data plate for approval information.

### AVAILABLE CONFIGURATIONS

#### R-Series Models

RIF132HUT-FHS

#### Door(s)

Full Height Solid

**\*Remote application available,  
 see form TR35837 for details.**

- **GUARANTEED FOR LIFE CAM-LIFT HINGES**
- **GUARANTEED FOR LIFE HORIZONTAL WORK FLOW DOOR HANDLES (SOLID DOORS ONLY)**

Approved by \_\_\_\_\_ Date \_\_\_\_\_ Approved by \_\_\_\_\_ Date \_\_\_\_\_



# R-Series

Roll-In Freezer Model for 72" High Racks  
32" Deep, Self-Contained

## MODEL

RIF132HUT-FHS

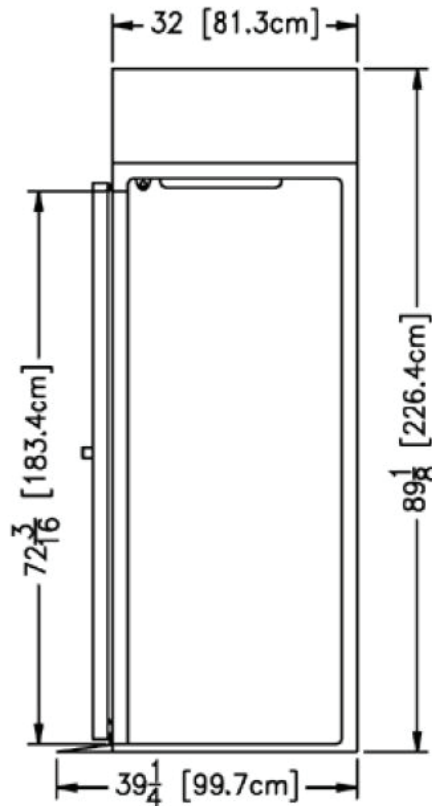
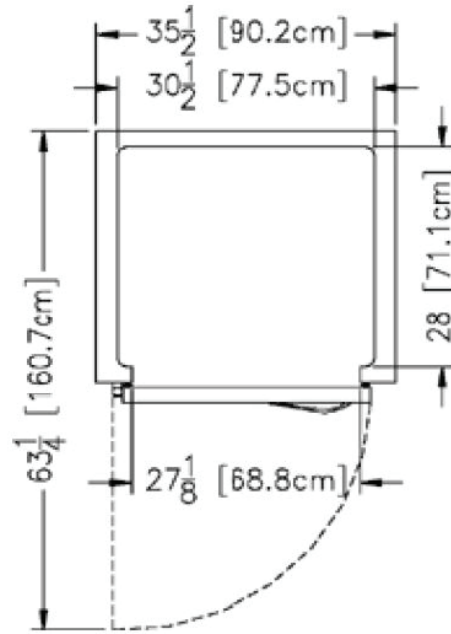
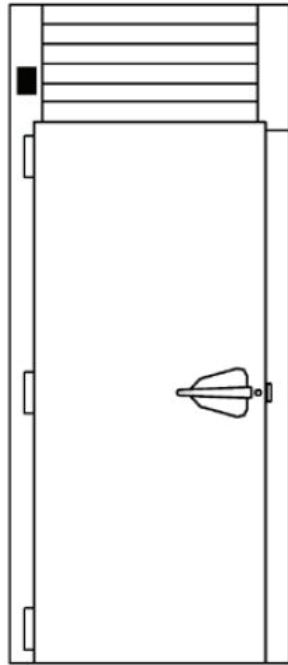

➤ CAD and/or Revit Files Available

<https://traulsen.klccad.com/>



### MODEL

RIF132HUT-FHS

MODELS	RIF132HUT-FHS
<b>DIMENSIONAL DATA</b>	
Net capacity cu. ft.	38.2 (1081.7 cu l)
Length - overall in.	35 1/2" (90.2 cm)
Depth - overall in.	39 1/4" (99.7 cm)
Depth - over body in.	32" (81.3 cm)
Depth - door open 90° in.	63 1/4" (160.7 cm)
Clear door width in.	27 1/8" (68.8 cm)
Clear door height in.	72 3/16" (183.4 cm)
Height - overall in. <sup>2</sup>	89 1/8" (226.4 cm)
Capacity - 66" High	1
<b>ELECTRICAL DATA</b>	
Voltage   Plug	115/60/1   NEMA 5-15P
Full Load Amperes   MDEC <sup>3</sup>	9.4   9.29 kWh/Day
<b>REFRIGERATION DATA</b>	
Refrigerant	R-448A
Refrigerant Charge Amount oz.	15 (425.24 g)
BTU/HR   H.P. <sup>1</sup>	2160   1/2 HP
<b>SHIPPING DATA</b>	
Length - Crated in.	48" (121.9 cm)
Width - Crated in.	42" (206.7 cm)
Height - Crated in.	94" (238.8 cm)
Volume - Crated cu. ft.	109.67 (3105.5 cu l)
Weight - Crated lbs.	790 (358.3 kg)

**NOTES:** Figures in parentheses reflect metric equivalents.

1. Based on a 90°F ambient and -10°F evaporator.
2. 12" Top clearance preferred for optimum performance & service access.
3. MDEC = Maximum Daily Energy Consumption

When ordering please specify: Voltage, Hinging, and Options.

Equipped with one NEMA 5-15P Plug



### EQUIPMENT SPECIFICATIONS

#### CONSTRUCTION, HARDWARE, INSULATION

Cabinet exterior front, one piece sides, louver assembly & door is constructed of heavy gauge stainless steel with #4 finish. Cabinet interior & door liner is constructed of stainless steel. The exterior cabinet top, back & bottom are constructed of heavy gauge galvanized steel. The interior floor is constructed of stainless steel & insulated with 3/4" of resilient cork. A readily attachable stainless steel ramp is provided to facilitate loading/unloading.

Door is equipped with heavy-duty, extruded wiper gasket for sealing to bottom ramp, removable plug cylinder locks & guaranteed for life cam-lift, gravity action, self-closing metal, glide hinges with stay open feature at 120 degrees. Hinges include a concealed switch to automatically activate the interior LED lighting. Guaranteed for life, work flow door handles are mounted horizontally over recess in door which limits protrusion from door face into aiseways. Door has seamless, polished metal corners.

Gasket profile & EZ-Clean material simplify cleaning & increase overall gasket life. Both the cabinet & door are insulated with an average of 2" thick high density, non-CFC, foamed in place polyurethane.

#### SELF-CONTAINED REFRIGERATION SYSTEM

A top mounted, self-contained, balanced refrigeration system using environmentally friendly, non-flammable R-448A refrigerant is conveniently located behind the one piece louver assembly. It features a finless StayClear™ condenser, thermostatic expansion valve, air-cooled hermetic compressor, large, high humidity evaporator coil located outside the food zone & top mounted non-electric condensate evaporator. A 9' cord & plug is provided. Standard operating temperature is 0 to -5°F (all models are -10°F capable in up to 100°F ambient).

#### CONTROL

Traulsen's Smart Control features advanced control algorithms & sophisticated diagnostic capabilities to optimize performance. Utilizing Smart Sensors, it adapts the operation of the refrigeration system to a variety of environments & usage patterns. The Smart Control also offers a complete set of visual alarms designed to alert the user to critical events such as power outages or a prolonged door opening. In the event of an alarm, a dedicated Alarm LED will illuminate, informing the user of the critical event and duration.

#### INTERIOR

Readily removable, interior-mounted, stainless steel guides for racks are provided for protection. Maximum rack size with wheels inboard of frame is 27" wide by 29" deep by 72" high. Racks are supplied by others.

#### WARRANTY

Both a six year parts and labor warranty and a seven year compressor warranty (self-contained models only) are provided standard.

CONTINUED PRODUCT DEVELOPMENT MAY NECESSITATE SPECIFICATION CHANGES WITHOUT NOTICE.