



Project \_\_\_\_\_  
 AIA # \_\_\_\_\_ SIS # \_\_\_\_\_  
 Item # \_\_\_\_\_ Quantity \_\_\_\_\_ C.S.I. Section 114000

## A-Series

W-Width Reach-In Freezer Model  
 32" Deep, Self-Contained



### STANDARD PRODUCT FEATURES

- Traulsen's Smart Control with LED Display
- -10°F Capable in up to 100°F Ambient
- StayClear™ Condenser Coil
- Stainless Steel Exterior/Anodized Aluminum Interior
- Balanced, Self-Contained Refrigeration System Using R-448A
- Rear Biased Return Air Duct
- Full or Half-Height Stainless Steel Doors with Locks
- Anti-Condensate Door Perimeter Heater
- Self-Closing Doors with Stay Open Feature at 120 Degrees
- Standard Door Hinging: 232W = Left/Right (other hings available)
- Automatically Activated LED Lights
- Stainless Steel Breaker Caps
- Three Adjustable, Coated Wire Shelves Per Section, Supported on Shelf Pins (factory installed)
- Automatic Non-Electric Condensate Evaporator
- Magnetic Snap-In EZ-Clean Door Gaskets
- Gasket-Protecting Raised Door Liners
- Thermostatic Expansion Valve Metering Device
- Stainless Steel One-Piece Louver Assembly
- 9' Cord & Plug Attached
- Set of (4) 6" High Adjustable Stainless Steel Legs

### ACCESSORIES & OPTIONS

- R-290 Refrigerant Option
- Option to Relocate Electrical Box
- Stainless Steel Finished Back with Rear Louvers
- #1 Type Trayslides to Accommodate either (1) 18" x 26" or (2) 14" x 18" Pans
- #4 Type Trayslides to Accommodate 18 to 19 Levels for 18" x 26" Pans
- Universal Type Trayslides to Accommodate Either (1) 18" x 26", (2) 14" x 18", or (2) 12" x 20" Pans
- Additional Coated Wire or Optional Stainless Steel Shelves
- Stainless Steel Banking Strip
- Locking Hasps (padlocks supplied by others)
- EZ-Change Interiors (#1, universals, universal heavy duty trayslides & shelves)
- EZ-Open Foot Pedals (full-height doors only)
- Positive Action Latch (consult factory)
- Kool Klad Exterior Laminate Decor (consult factory)
- Optional 208-230/115/60/1, 208-230/60/1, or 208-230/115/60/1 High Capacity Voltages
- Export 220-240/50/1 Voltage
- Set of (4) 4<sup>5</sup>/<sub>8</sub>" or 6" High Casters in Lieu of Legs
- 6" Stainless Steel Flanged Legs
- Other Support Options: 4<sup>1</sup>/<sub>2</sub>" High Base or 6" High Kickplate (for use with standard legs)
- Heat Shield
- Remote Glycol Application (consult factory)



Intertek



This unit is listed to the applicable UL, CSA and NSF Standards by an approved NRTL. Consult the factory or unit's data plate for approval information.

### AVAILABLE CONFIGURATIONS

#### A-Series Models

ALT232WUT-FHS  
 ALT232WUT-HHS

#### Door(s)

Full Height Solid  
 Half Height Solid

**\*Remote application available,  
 see form TR35837 for details.**

- **GUARANTEED FOR LIFE CAM-LIFT HINGES**
- **GUARANTEED FOR LIFE HORIZONTAL WORK FLOW DOOR HANDLES (SOLID DOORS ONLY)**

Approved by \_\_\_\_\_ Date \_\_\_\_\_ Approved by \_\_\_\_\_ Date \_\_\_\_\_



# A-Series

W-Width Reach-In Freezer Model  
32" Deep, Self-Contained

## MODEL

ALT232WUT-HHS  
ALT232WUT-FHS

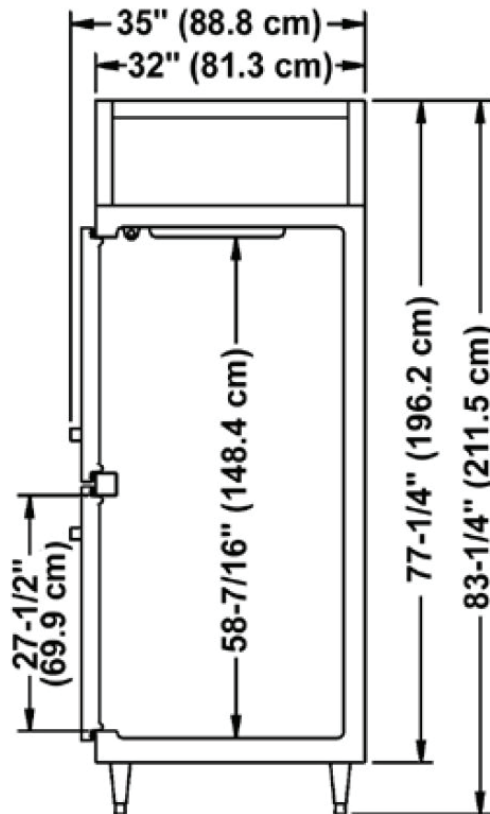
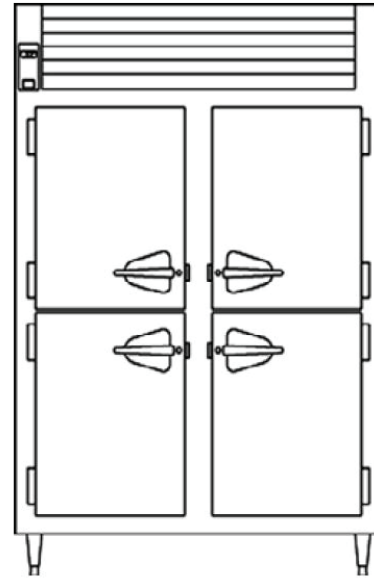
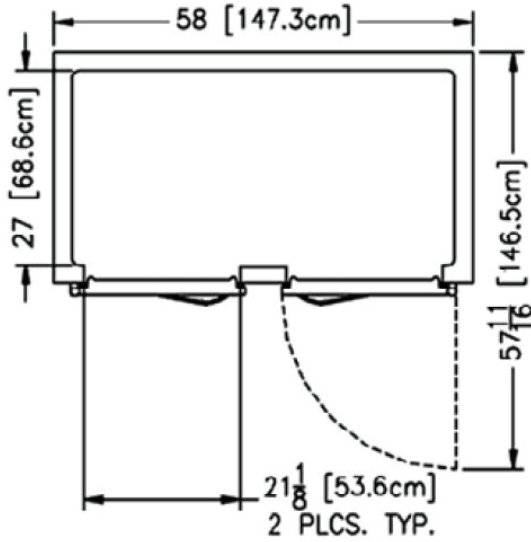

> CAD and/or Revit Files Available

<https://traulsen.klccad.com/>



### MODEL

ALT232WUT-HHS  
ALT232WUT-FHS

MODELS	ALT232WUT
<b>DIMENSIONAL DATA</b>	
Net capacity cu. ft.	50.53 (1430.9 cu l)
Length - overall in.	58" (147.3 cm)
Depth - overall in.	35" (88.8 cm)
Depth - over body in.	32" (81.3 cm)
Depth - door open 90° in.	57 11/16" (146.5 cm)
Clear door width in.	21 1/8" (53.6 cm)
Clear half-door height in.	27 1/2" (69.9 cm)
Clear full-door height in.	57 5/8" (146.3 cm)
Height - overall on 6" legs <sup>2</sup>	83 1/4" (211.5 cm)
No. Standard Shelves	6
Shelf area sq. ft.	27.78 (2.6 sq. m)
<b>ELECTRICAL DATA</b>	
Voltage   Plug	115/60/1   NEMA 5-20P
Full Load Amperes   MDEC <sup>3</sup>	16   11.87 kWh/Day
<b>REFRIGERATION DATA</b>	
Refrigerant	R-448A
Refrigerant Charge Amount oz.	29 (822.1 g)
BTU/HR   H.P. <sup>1</sup>	3790   3/4 HP
<b>SHIPPING DATA</b>	
Length - Crated in.	62" (157.5 cm)
Width - Crated in.	42" (106.7 cm)
Height - Crated in.	85" (215.9 cm)
Volume - Crated cu. ft.	128 (3624.6 cu l)
Weight - Crated lbs.	610 (276.7 kg)

**NOTES:** Figures in parentheses reflect metric equivalents.

1. Based on a 90°F ambient and -10°F evaporator.
2. 12" Top clearance preferred for optimum performance & service access.
3. MDEC = Maximum Daily Energy Consumption

When ordering please specify: Voltage, Hinging, and Options.

Equipped with one NEMA 5-20P Plug



### EQUIPMENT SPECIFICATIONS

#### CONSTRUCTION, HARDWARE, INSULATION

Cabinet exterior front, one piece sides, louver assembly & doors are constructed of heavy gauge stainless steel. Cabinet interior & door liners are constructed of heavy gauge anodized aluminum. The exterior cabinet top, back & bottom are constructed of heavy gauge galvanized steel. A set of four (4) adjustable 6" high stainless steel legs are included.

Doors are equipped with a gasket-protecting metal door pan, removable plug cylinder locks & guaranteed for life cam-lift, gravity action, self-closing metal, glide hinges with stay open feature at 120 degrees. Hinges include a concealed switch to automatically activate the interior LED lighting. Guaranteed for life, work flow door handles are mounted horizontally over recess in doors which limits protrusion from door faces into aiseways. Doors have seamless, polished metal corners.

Gasket profile & EZ-Clean material simplify cleaning & increase overall gasket life. Anti-condensate heaters are located behind the door opening. Both the cabinet & door is insulated with an average of 2" thick high density, non-CFC, foamed in place polyurethane.

#### SELF-CONTAINED REFRIGERATION SYSTEM

A top mounted, self-contained, balanced refrigeration system using environmentally friendly, non-flammable R-448A refrigerant is conveniently located behind the one piece louver assembly. It features a finless StayClear™ condenser, thermostatic expansion valve, air-cooled hermetic compressor, large, high humidity evaporator coil located outside the food zone & top mounted non-electric condensate evaporator. Rear biased return air duct protects against introduction of warm kitchen air, promoting even temperature maintenance & efficient operation. A 9' cord & plug is provided. Standard operating temperature is 0 to -5°F (all models are -10°F capable in up to 100°F ambient).

#### CONTROL

Traulsen's Smart Control features advanced control algorithms & sophisticated diagnostic capabilities to optimize performance. Utilizing Smart Sensors, it adapts the operation of the refrigeration system to a variety of environments & usage patterns. The Smart Control also offers a complete set of visual alarms designed to alert the user to critical events such as power outages or a prolonged door opening. In the event of an alarm, a dedicated Alarm LED will illuminate, informing the user of the critical event and duration.

#### INTERIOR

Standard interior arrangements include three (3) coated wire shelves per section, mounted on shelf pins. Shelves are full-width & do not have any large gaps between them requiring the use of "bridge" or "junior" shelves. Recommended load limit per shelf should not exceed 225 lbs. Interior arrangements are installed at the factory & EZ-Change interior slides (only) are field installed.

#### WARRANTY

Both a six year parts and labor warranty and a seven year compressor warranty [self-contained models only] are provided standard.

CONTINUED PRODUCT DEVELOPMENT MAY NECESSITATE SPECIFICATION CHANGES WITHOUT NOTICE.