



CE ISO 9001

XC112 FROZEN BEVERAGE MACHINE

The XC112 is a high volume slush machine designed for reliability and ease of use in an attractive mirror stainless finish that accents any placement. The XC112 offers an energy efficient refrigeration system for low cost operation, oversized LED backlit signage for merchandising appeal and no heat to melt the slush product, and simple controls for easy operation and perfect slush every time.

Features

- Large 3.2 gallon bowl for high volume applications
- Night time refrigeration mode for energy savings and to minimize cleaning
- Simple switch control functions for reliability and cost efficient maintenance
- Variable consistency control for perfect slush with any product
- Removable drip tray for easy draining and cleaning
- Mirror stainless steel with black trim for an attractive finish that is easy to clean

DONPER USA

Donper USA
24610 Kingsland Blvd
Katy, TX 77494

1-844-366-7371
sales@donperusa.com
www.donperusa.com

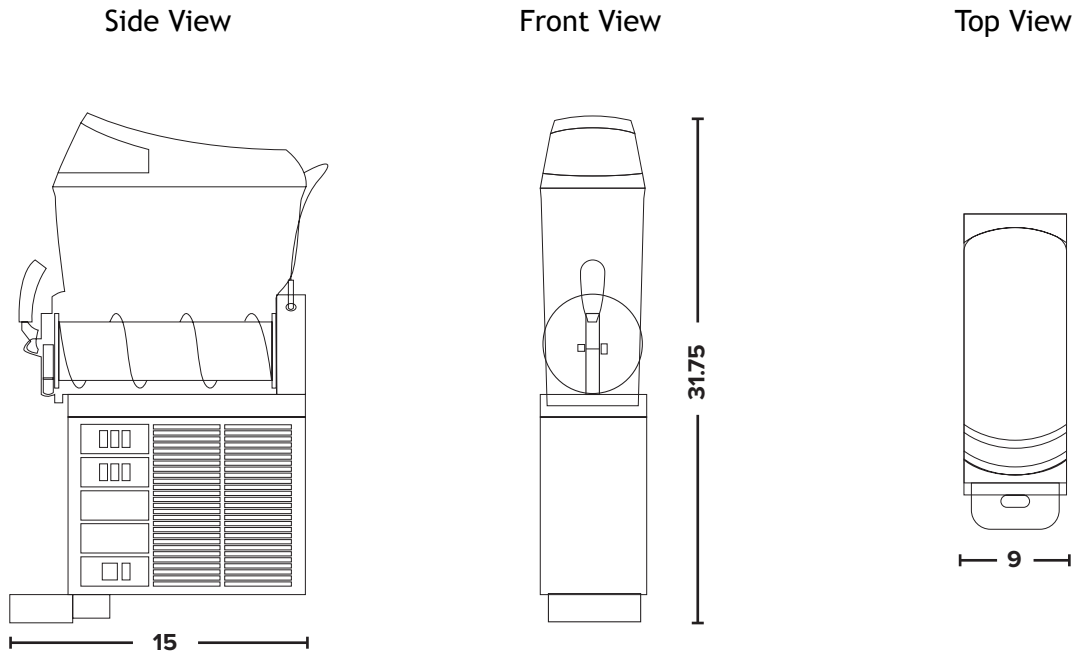

Measurements in inches.

Size and Capacity

Refrigerated Hopper	12.7 Qt (12 L)
Height	31.75 in (806 mm)
Width	9 in (229 mm)
Depth	15 in (381 mm)
Weight	69 lbs (31 kg)

Electrical

Voltage	115 v
Phase	Single
Rated Input Power	700 W
Compressor	1/3 HP
Hertz	60 Hz
Plug type	115 volt Standard Plug

Distributed By:
