

24 " Restaurant Series RANGE

▪ R 24 ST - 24 B ▪ R 24 CO - 24 B

100% manufactured from raw materials providing the highest quality and durability

STANDARD FEATURES

RANGE

- 2-year parts and labor warranty
- Lifetime Warranty Non-Clog Burners
- 7 " stainless steel belly rail
- 14 gauge fully welded interlocking frame
- 22.5 " Flue riser standard with shelf
- Standing pilot for open top burners
- Heavy duty 12 " x 12 " removable cast iron grates
- Stainless steel front and sides
- Metal Black insulated Knobs
- Heavy duty single over shelf
- 4 " Adjustable legs

OVEN

- 30,000 BTU/h oven with snap action thermostat from 175 °F to 550 °F (79.4 °C to 287.7 °C) and 100% safety shut off
- 26 ½ " Standard bakery depth on all ovens
- Spark ignition for oven bases
- Enamelled oven cavity (top, bottom and side)
- Heavy duty oven wired rack – 3/8 " diameter
- Standard oven has 4 shelf positions and 3 racks standard

CO – Forno Convector (Opcional)

- Dynamic Airflow Technology (DAT) Patented convection oven with a low-profile fan, 26 ½ " depth, and a high-pressure balanced air flow design
- 5 shelf positions and 4 racks standard
- Convection oven has an on/off switch and high/low fan speed
- Only Convection oven base that fits a full-size sheet pan on all models

OPTIONS & ACCESSORIES

- Modular belly rail accessory for 1/6 pans
- Cutting Board
- (4) 6" swivel casters with front locking brakes
- Oven Rack
- Quick disconnect (3/4 Flex hose quick disconnect 4' long)
- Stub Back Flue Riser



Model R 24 ST - 24 B

SPECIFICATIONS

RANGE

- 32,000 BTU/h Burners, providing maximum control and best heat distribution in the industry
- ¾ " NPT rear gas connect and pressure regulator for both natural gas and propane
- Manifold pressure is 4 " W.C. (Natural Gas) or 10 "W.C. (Propane Gas)
- Each burner is controlled by a gas valve for independent control of flame One standing pilot services each burner
- 4 " stainless steel, adjustable legs.

OVEN

- 30,000 BTU/h burners
- One standing pilot services the burner
- 30,000 BTU/h burners
- One standing pilot services e burner



24 " Restaurant Series RANGE

Rev 02 (AGO/2019)

▪ R 24 ST - 24 B ▪ R 24 CO - 24 B

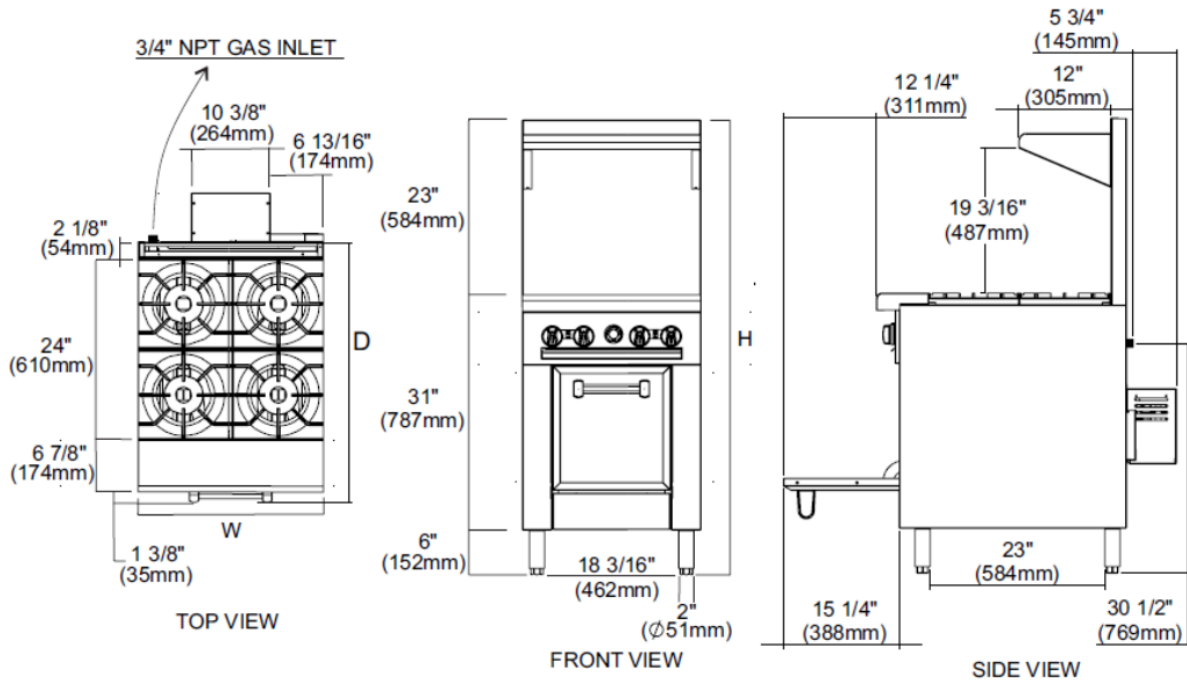

Model	Exterior Product Dimensions & Weight				Shipping Crate Dimensions & Weight			
	Width	Depth	Height	Weight	Width	Depth	Height	Weight
R 24 ST - 24 B	24 " (610 mm)	34 ¼ " (871 mm)	60 " (1524 mm)	392 lb (178 Kg)	28 5/32" (715mm)	38 3/8" (975mm)	44 3/32" (1120mm)	390 lb (177 Kg)
R 24 CO - 24 B	24 " (610 mm)	42 ¼ " (1073 mm)	60 " (1524 mm)	485 lb (220 Kg)	28 5/32" (715mm)	45 9/32" (1150mm)	44 3/32" (1120mm)	573 lb (260 Kg)

Model	Oven Interior		
	Width	Depth	Height
Standart	18 ½ " (470 mm)	26 ½ " (673.1 mm)	14 " (355.6 mm)
Convection	18 ½ " (470 mm)	26 ½ " (673.1 mm)	14 " (355.6 mm)

GAS SUPPLY

Model	Burners (Range)	Gas (BTU/h)		Burners (Oven)	Gas (BTU/h)	
		Natural	Propane		Natural	Propane
All Models	4	128,000	120,000	1	30,000	27,000

UTILITY INFORMATION

Manifold Pressure	
Natural Gas	Propane Gas
4 " W.C.	10 " W.C.

- ¾ " NPT rear Gas inlet.
- Specify elevation, if over 2000 ft
- LP conversion kit included

ELETRICAL

Convection Oven with ¼ HP, 115 V, 60 Hz, 3.30/3.70 A, 1 phase motor , 1125 and 1725 rpm supplied with 6.5 ' (2000 mm) cord

CLEARANCES REQUIREMENTS

• Provide side and rear clearance 0 " (0 mm) from non-combustible surfaces. 6 " (152.4 mm) - sides and, 8 " (203.2 mm) – rear, clearance from combustible surfaces.

MISCELANEOUS

- Install under vented hood
- Check local codes for fire, installation and sanitary regulations
- Intended for commercial use only. Not for household use

