

<b>REFRIGERATOR MANUFACTURER</b>  <b>Turbo air</b> more durable, efficient, beautiful	4184 E. Conant St. Long Beach, CA 90808 Tel. 310-900-1000 Fax. 310-900-1077 <a href="http://www.turboairinc.com">www.turboairinc.com</a>	Project:	
		Model #:	
		Item #:	
		Available W/H:	Qty:
		Approval:	
		AIA #:	SIS #:
		CSI Section 11400	

# Straight Front Bakery Cases

*Display Cases*  
*European Straight Front Cases - Dry Cases*

**Model : TCGB-48UF-DR-S**



## ≡ FEATURES & BENEFITS ≡

- **Attractive, elegant, glass sided Euro design**  
Straight tempered front glass and minimal frame provide full product visibility to optimize display effects. Its elegant contemporary euro design will not only enhance any store atmosphere but also will keep product presentation at its best and most beautiful.
- **LED interior lighting under each shelf**
- **High-density polyurethane insulation**  
The entire cabinet structure is foamed-in-place using high density, CFC free polyurethane insulation.
- **Low-E coated double pane glass is tempered for safety**
- **Adjustable, tempered glass shelves with stainless steel front and back edges**
- **Stainless steel floor**
- **Sliding rear doors for product loading & unloading**



Model	CU./FT.	# of Shelves	HP	AMPS	Crated Weight (lbs.)	L x D x H* (inches)
<b>TCGB-48UF-DR-S</b>	<b>15.6</b>	<b>2</b>	<b>-</b>	<b>0.6</b>	<b>580</b>	<b>48 1/2 x 33 1/8 x 50 1/8</b>

# Straight Front Bakery Cases

Display Cases  
European Straight Front Cases - Dry Cases

## Model : TCGB-48UF-DR-S

ELECTRICAL DATA	
Voltage	115/60/1
Plug Type	 NEMA 5-15P
Full Load Amperes	0.6
Compressor HP	-
Cord Length (ft.)	47/8
Refrigerant	-
DIMENSIONAL DATA	
Net Capacity (cu. ft.)	15.6
Ext. Length Overall (in.)	48 1/2 (1231mm)
Ext. Depth Overall (in.)	33 1/8 (841mm)
Ext. Height Overall (in.)*	50 1/8 (1272mm)
Int. Length Overall (in.)	45 1/4 (1150mm)
Int. Depth Overall (in.)	21 1/2 (546mm)
Int. Height Overall (in.)	25 5/8 (650mm)
Shelf Size (L x D) (in.)	44 3/8 x 16 3/4
	44 3/8 x 18 3/4
# of Shelves	2
Net Weight (lbs.)	454
Gross Weight (lbs.)	580

Design and specifications subject to change without notice.

Actual shipping weight may differ due to extra packing materials for product protection.

\* Height does not include 5/8" for bolt height.

### ■ WARRANTY : 2 Year Parts and Labor Warranty

### ■ STANDARD FEATURES

- Bolt height adjustable up to 2 3/4"

### ■ OPTIONAL ACCESSORIES

- 1.6" caster: CAS16WBT00 (non-brake)
- 4" caster, 1/2" diameter & 13 TPI: G8F6500101 (non-brake), G8F6500201 (w/ brake)
- 6" leveling seismic leg (1/2", 13 TPI): 30221M0700

## PLAN VIEW

(unit : inch)

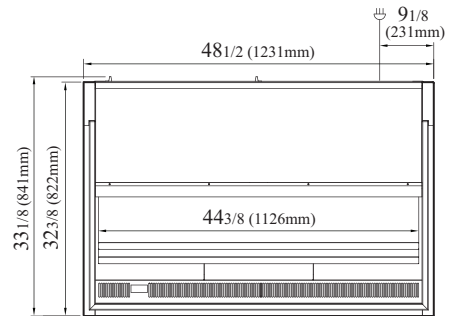

TOP VIEW

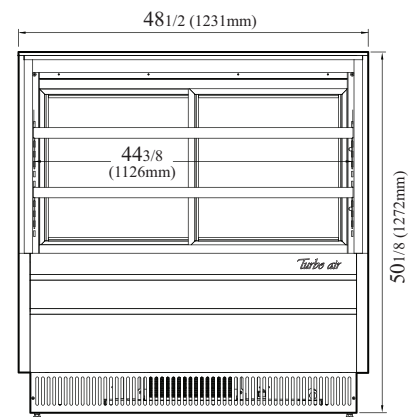

FRONT VIEW

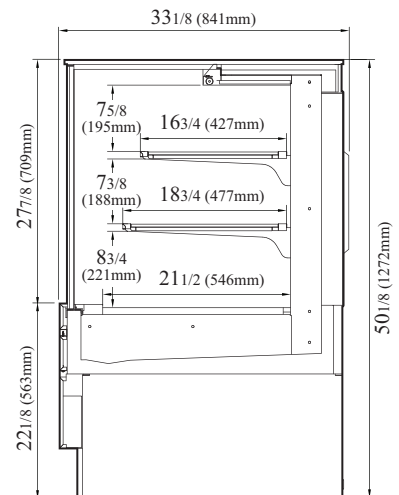

SIDE VIEW

Ver.20240220



- Turbo Air: 800-627-0032
- Radiance: 800-500-3519
- Warranty: 800-381-7770
- AC: 888-900-1002