

6000XL®

Glass Door Reach-In Refrigerator

Models

- 6025XL-G Single section full height door
- 6025XL-GH Single section half height doors
- 6051XL-G Two section full height doors
- 6051XL-GH Two section half height doors



6025XL-GH
*Left hinge option shown

Standard Features

- Stainless steel front shroud and sides
- Seamless, Delrite® ABS interior liner
- GreenGenius R290 top mount refrigeration system featuring TXV expansion valve and hot gas condensate removal
- Easy to adjust chrome shelves (three per section)
- Easy to read digital thermometer with visual high/low temp alarms
- 10' cord and plug attached
- Edgemount door hinges
- Pressure relief valve is standard to prevent door vapor locking
- High density foamed in place, environmentally friendly, Kyoto protocol Compliant, Non ODP (Ozone Depletion Potential), Non GWP (Global Warming Potential) polyurethane insulation keeps energy costs low
- Energy efficient door gasket - removable without tools
- Interior accepts 18" x 26" sheet pans on shelves or on optional tray racks
- Self closing doors with stay open feature at 120°
- Three year parts and labor and additional four year compressor parts warranty.
- Right hinged door standard
- Field Rehingeable Door(s)

Options

- Extra shelves
- Tray rack (TR-8B)
- Left hinged door

Specifications

Exterior: Top and bottom are constructed of 24-gauge galvanized steel. Exterior sides are stainless steel. Front housing is 22-gauge stainless steel.

Doors: Unit is provided with hinged glass front door(s). Doors are provided with locks, magnetic gaskets, self-closing, edgemount hinges; and quick grip door handle(s).

Interior: Liner is constructed of seamless, one piece ABS material with 15 molded shelf supports spaced 3" (76mm) apart. Three chrome wire shelves are provided per section. Liner comes with a limited lifetime warranty.

Units are completely insulated with a minimum of 2" (5cm) high density foamed in place environmentally friendly Kyoto protocol Compliant, Non ODP (Ozone Depletion Potential), Non GWP (Global Warming Potential) polyurethane.

Interior is lit by an LED light. Lights are located outside of the food zone.

Refrigeration system: All components are mounted to the top cabinet ceiling, outside the food zone and are assembled as one piece and can be removed as

one piece. Environmentally friendly R290 refrigerant is used. System has the capability of maintaining between 33°F and 40°F in heavy use food service operations. Refrigerant is metered using a highly responsive thermostatic expansion valve. System is controlled using an electronic temperature control, which provides improved pull down times, reducing compressor cycling and longer compressor life with lower energy consumption. Control system uses adaptive defrost to assure evaporator coil is free of ice and operating at optimum efficiency. Evaporator condensate is eliminated using an energy efficient hot gas system.

Other: Unit to be mounted on legs. Casters not available for Glass door units



6000XL Glass Door Reach-In Refrigerator

6000XL Glass Door Reach-In Refrigerator

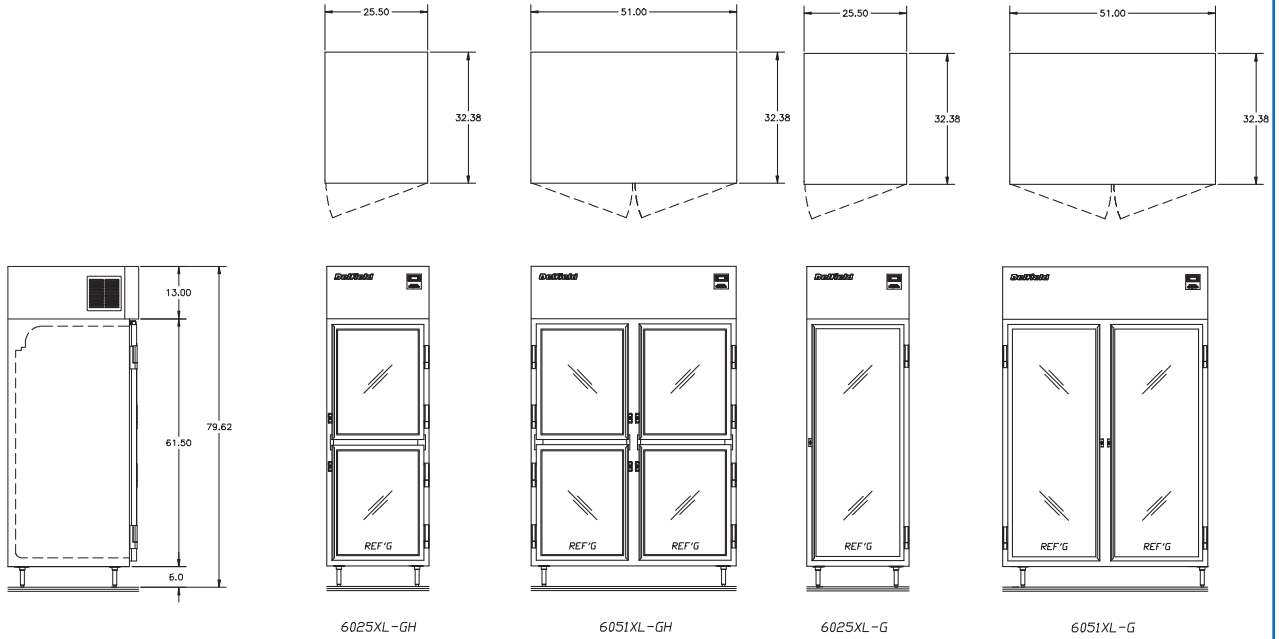

6025XL-GH

6051XL-GH

6025XL-G

6051XL-G

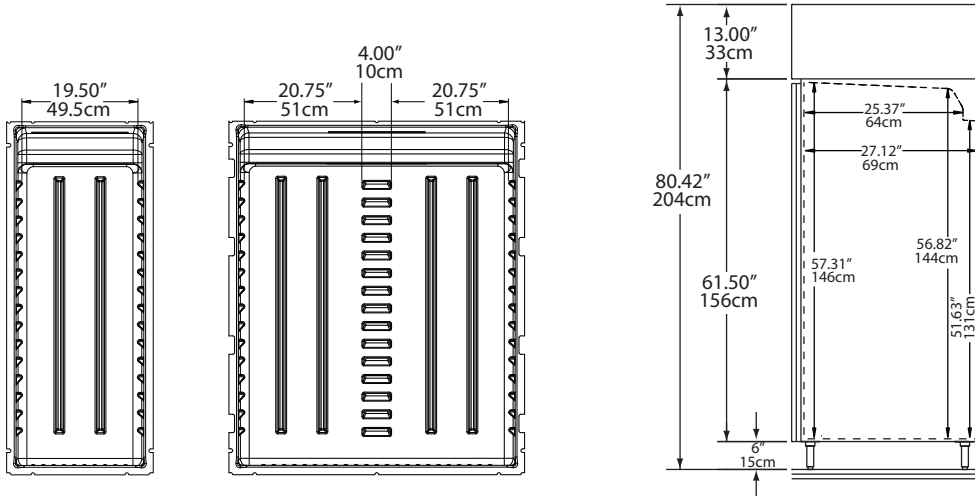

Specifications										
Description	Model	V/Hz/ph	Amps	Shelf Capacity (FT ²)	Storage Capacity (FT ³)	H.P.	BTU	Nema Plug	Energy (KWH/Day)	Ship Weight
1-section Refrigerator	6025XL-G	115/60/1	4.2	15.1	20	.22	1754	5-15P	1.6	301lbs/136kg
1-section Half Door Refrigerator	6025XL-GH	115/60/1	4.2	15.1	20	.22	1754	5-15P	1.7	301lbs/136kg
2-section Refrigerator	6051XL-G	115/60/1	6.0	43.5	33.2	0.33	2167	5-15P	2.3	451lbs/205kg
2-section Half Door Refrigerator	6051XL-GH	115/60/1	6.0	43.5	33.2	0.33	2167	5-15P	2.89	451lbs/205kg

Welbilt reserves the right to make changes to the design or specifications without prior notice.