

GRANDEMAX COMBO

HIGH PRODUCTION FLOUR TORTILLA MACHINE

MODEL 20X OVEN SPEC

120 or 240 Volts
3.0 Amps
Cycles/Phase: 60HZ/Single
Natural Gas: 100,000 BTU's
Dimensions vary with conveyor length
Conveyor Lengths: 30", 42", 60"
Conveyor Lengths: 77 cm, 107 cm, 153 cm
Weight: Approx. 830 lbs./377 Kg



Receptacle:
NEMA 5-20P
(125V ~)



Receptacle:
NEMA 5-20R
(125V ~)



Receptacle:
NEMA 6-20P
(250V ~)



Receptacle:
NEMA 6-20R
(250V ~)

MODEL 12L PRESS SPEC

220 or 240 Volts
37.5 Amps
Cycles/Phase: 60HZ/Single
Dimensions w/o Dough Loader:
L34.34" X W 21.5" X H 23.16"
Shipping Weight: Approx. 215 lbs.
Tortilla Production: Up to 1800
Ready-to-cook tortillas per hour!
Tortilla Diameter Single Drop: 10" / 28cm
Tortilla Diameter Double Drop: 7" / 10cm

*Tortilla production may vary due to operator experience, diameter and thickness of tortillas.



Plug:
NEMA 10-50P
(250V ~)



Receptacle:
NEMA 10-50R
(250V ~)

- Energy Efficient and Easy to Operate!
- The Ultimate in Display Cooking!
- Optional Dough Trolley Loader!

- A Unique Machine offering Versatility and Consistency!
- Double Drop! Press 2 Dough Balls at the same time!



*BE&SCO equipment is solely intended for use in a commercial facility.



200 Lombrano St · San Antonio, TX 78207 USA
Office: (210) 734-5124 · Fax: (210) 737-3925
Toll Free: 1-800-683-0928
Email: sales@bescomfg.com · Website: www.bescomfg.com
Visit our website to view video www.bescomfg.com



Certifications Applicable to Press and Oven Only
*Certifications Not Applicable to Stands

Revised: 03/05/2020

Grandemax Combo, Straight Exit

Model: 20X, 12L, 29A

(Shown with Model 78 DTL and 30" Exit Conveyor)

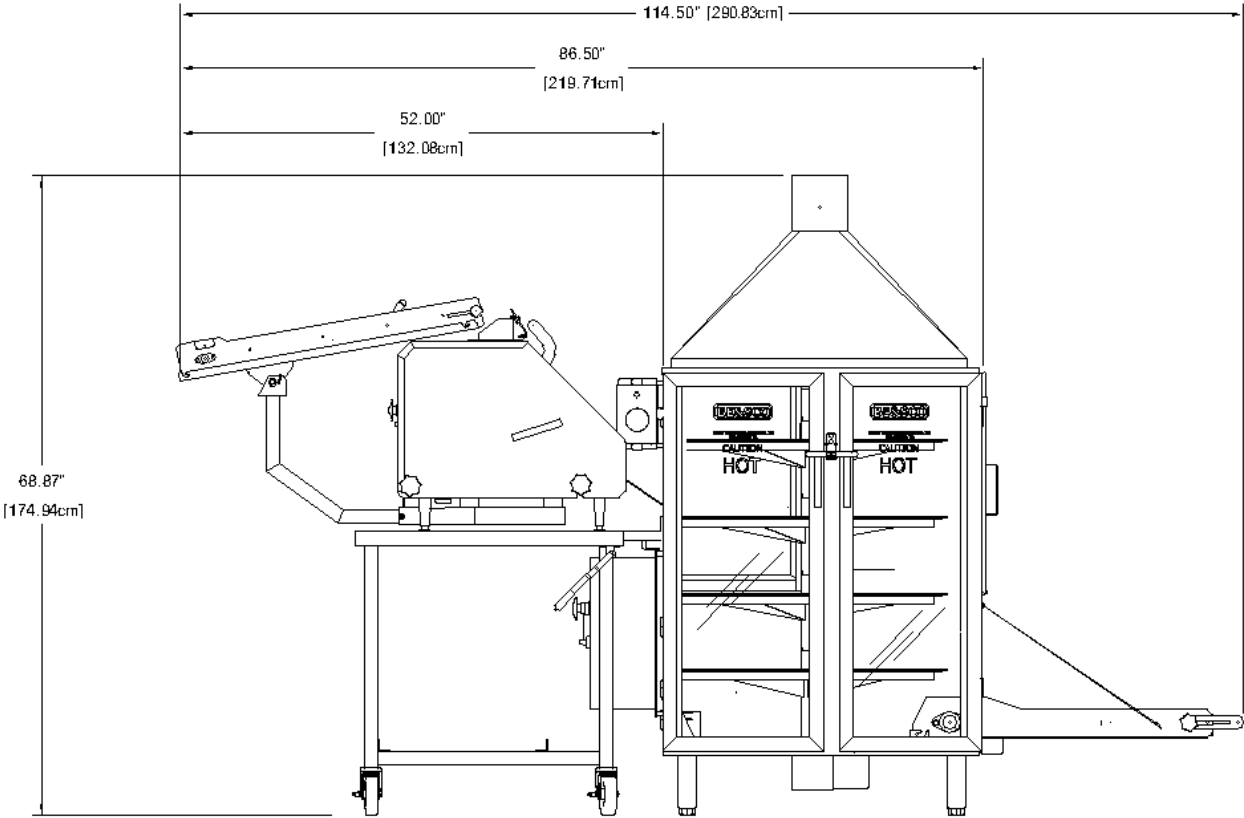
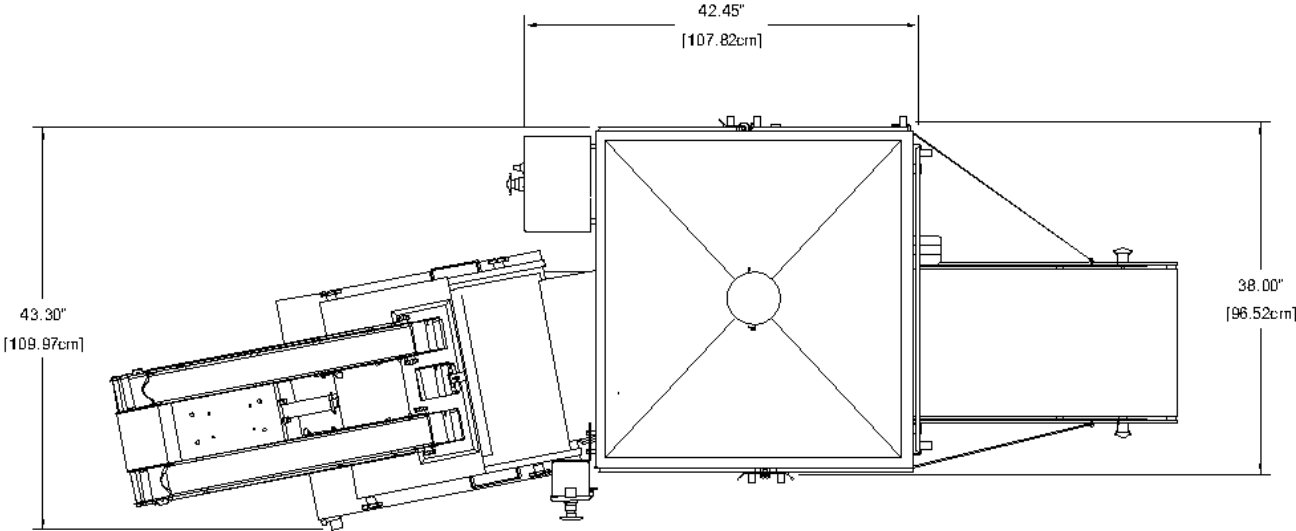

Grandemax Combo, Straight Exit

Model: 20X, 12L, 29A

(Shown with Model 78 DTL and 42" Exit Conveyor)

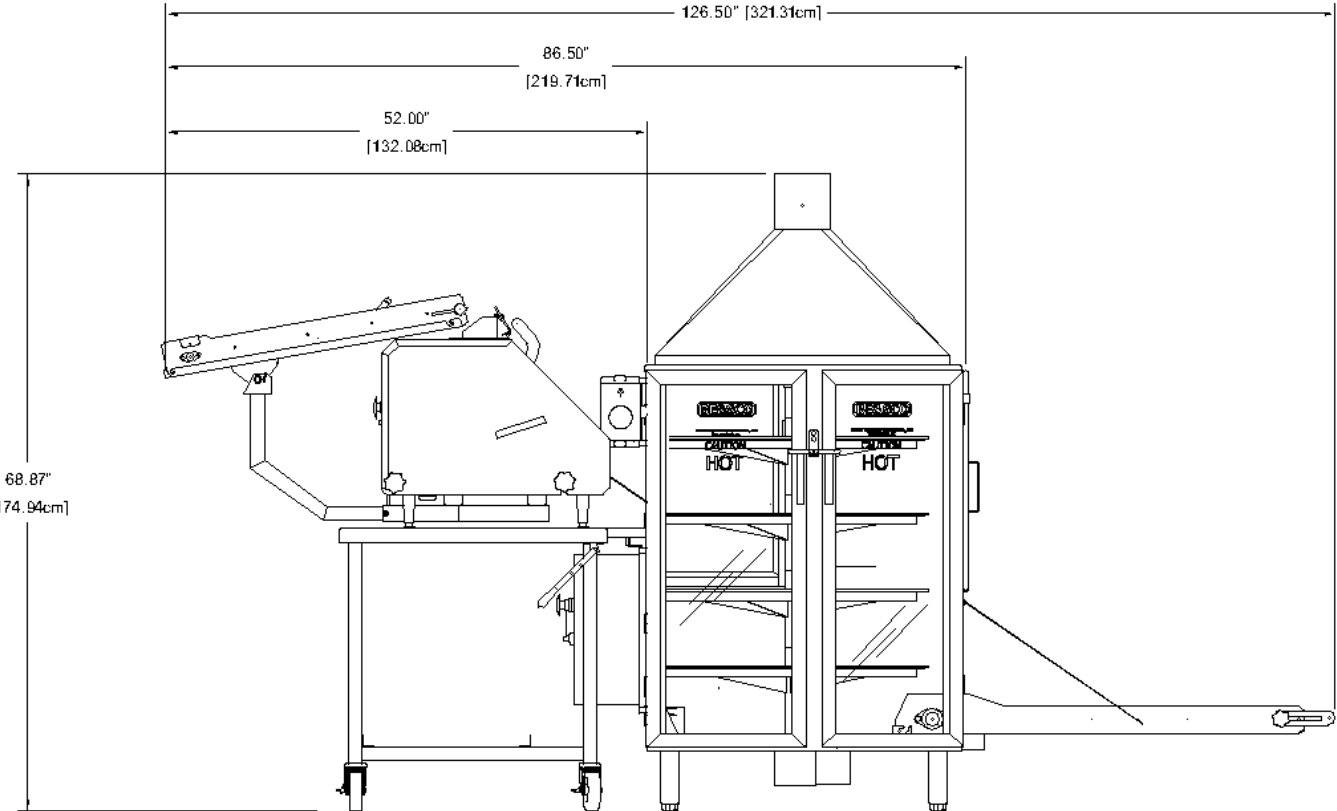
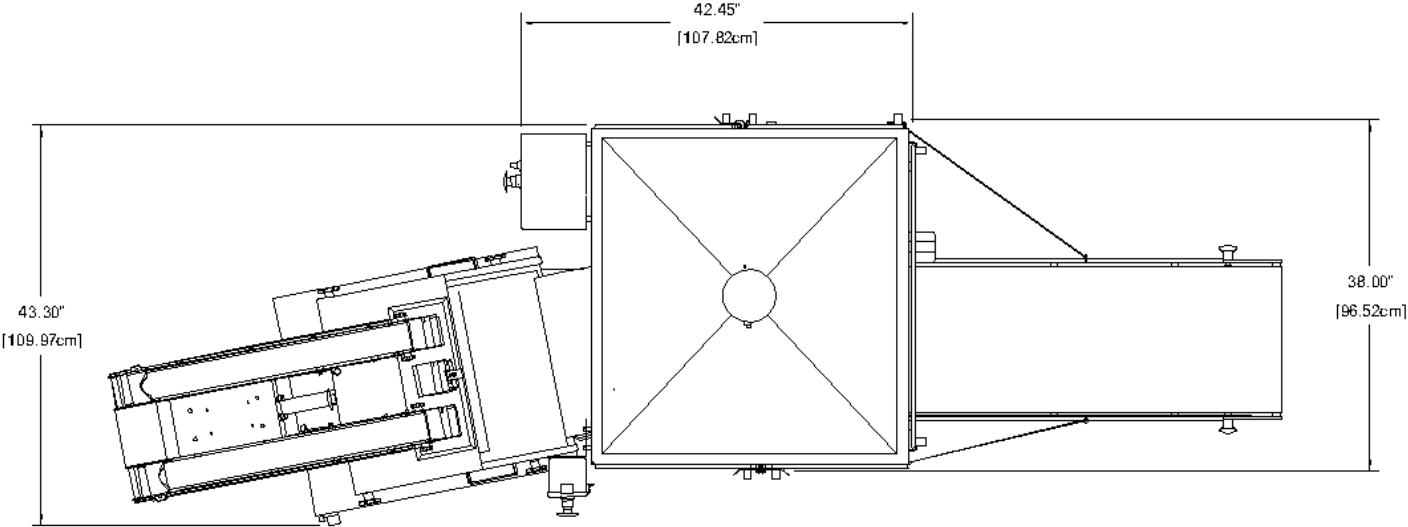

Grandemax Combo, Straight Exit

Model: 20X, 12L, 29A

(Shown with Model 78 DTL and 60" Exit Conveyor)

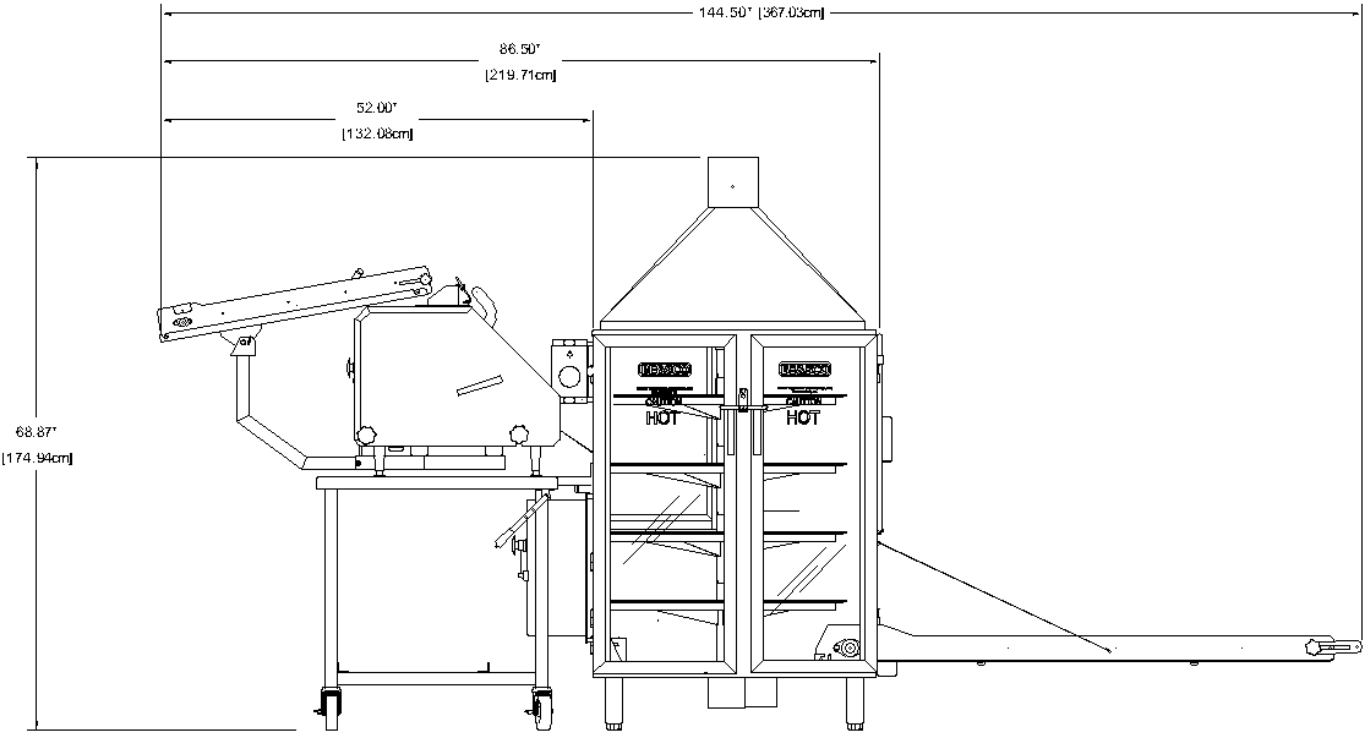
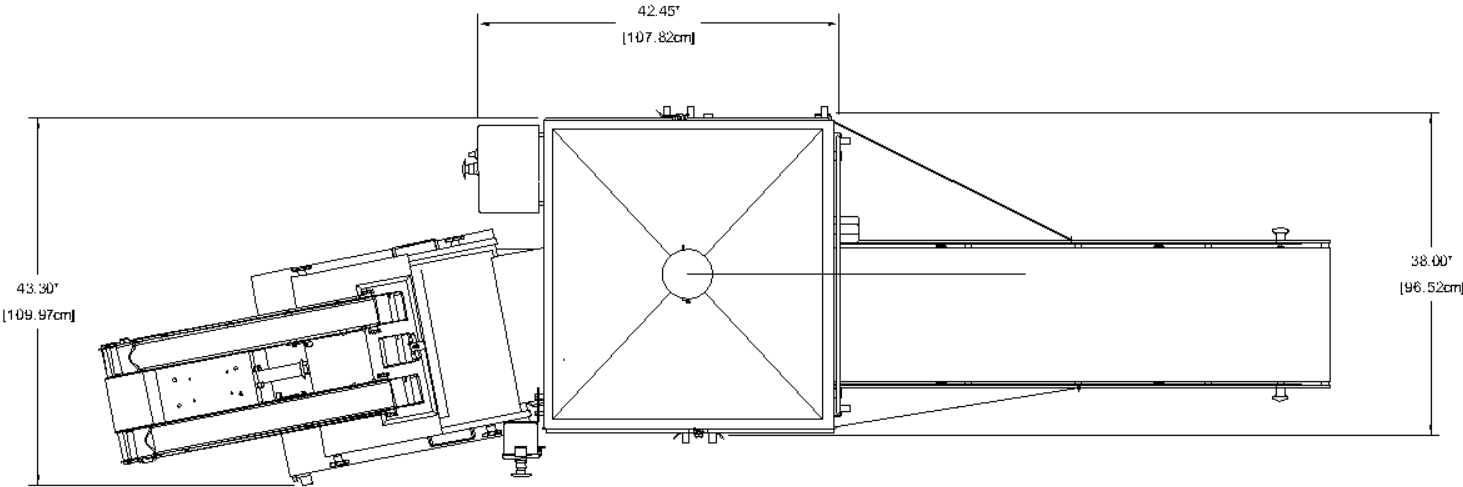

Grandemax Combo, Right Exit

Model: 20X, 12L, 29A

(Shown with Model 78 DTL and 30" Exit Conveyor)

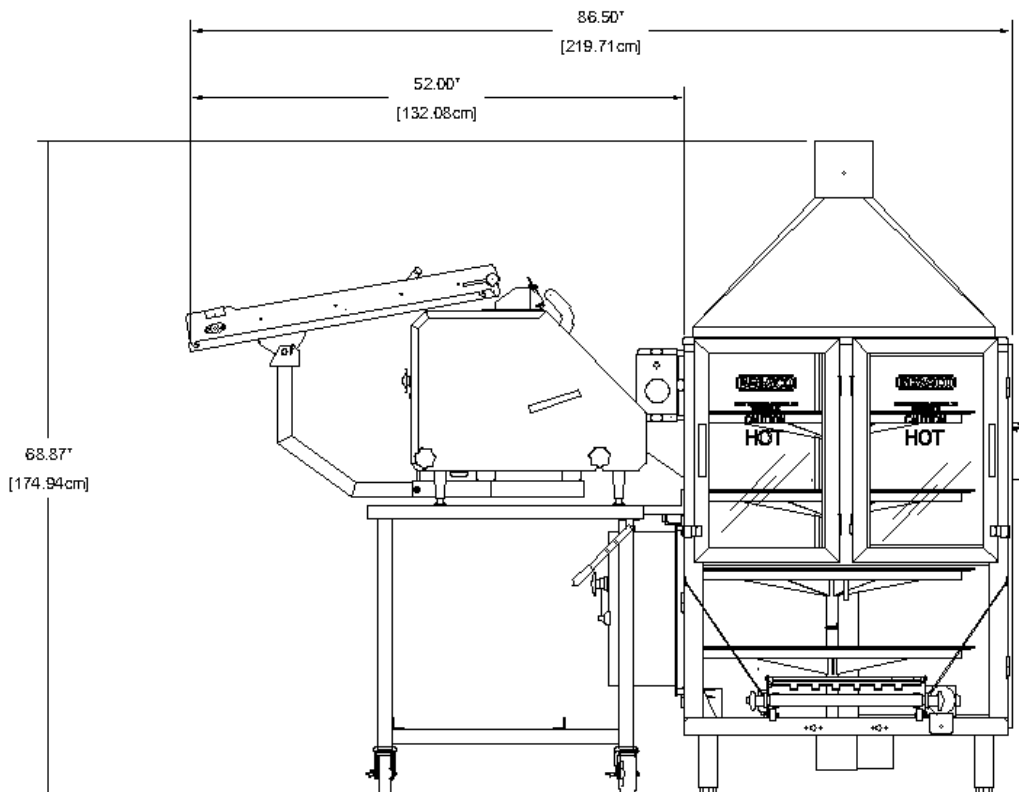
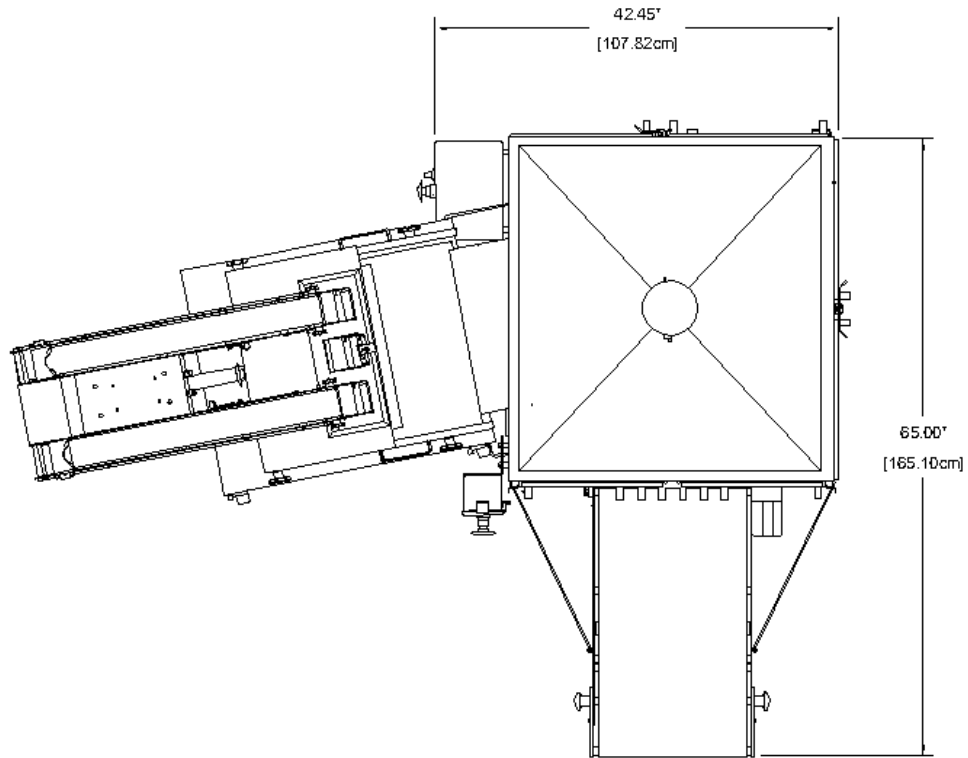

Grandemax Combo, Right Exit

Model: 20X, 12L, 29A

(Shown with Model 78 DTL and 42" Exit Conveyor)

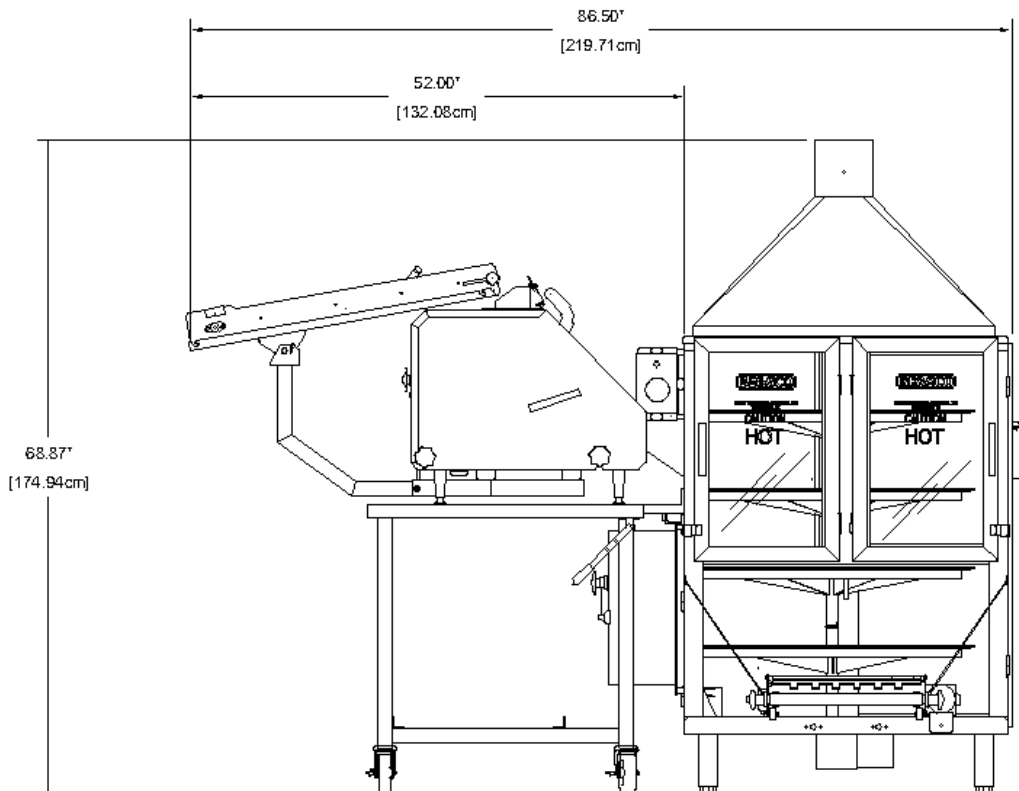
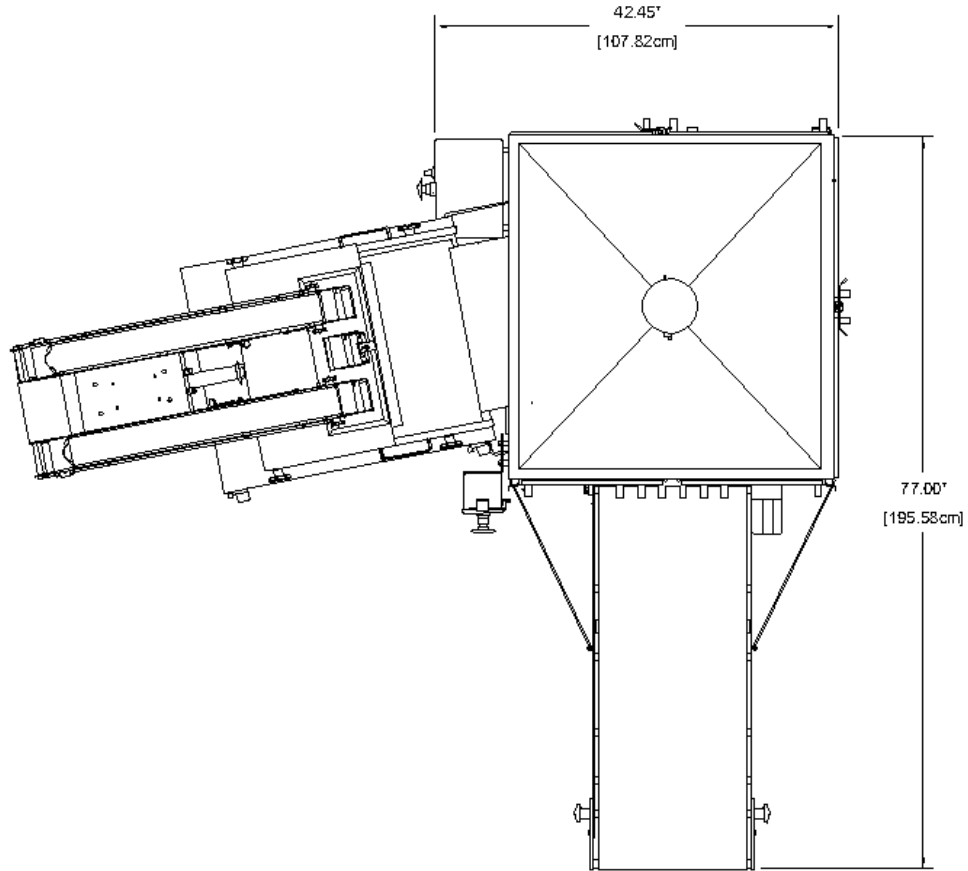

Grandemax Combo, Right Exit

Model: 20X, 12L, 29A

(Shown with Model 78 DTL and 60" Exit Conveyor)

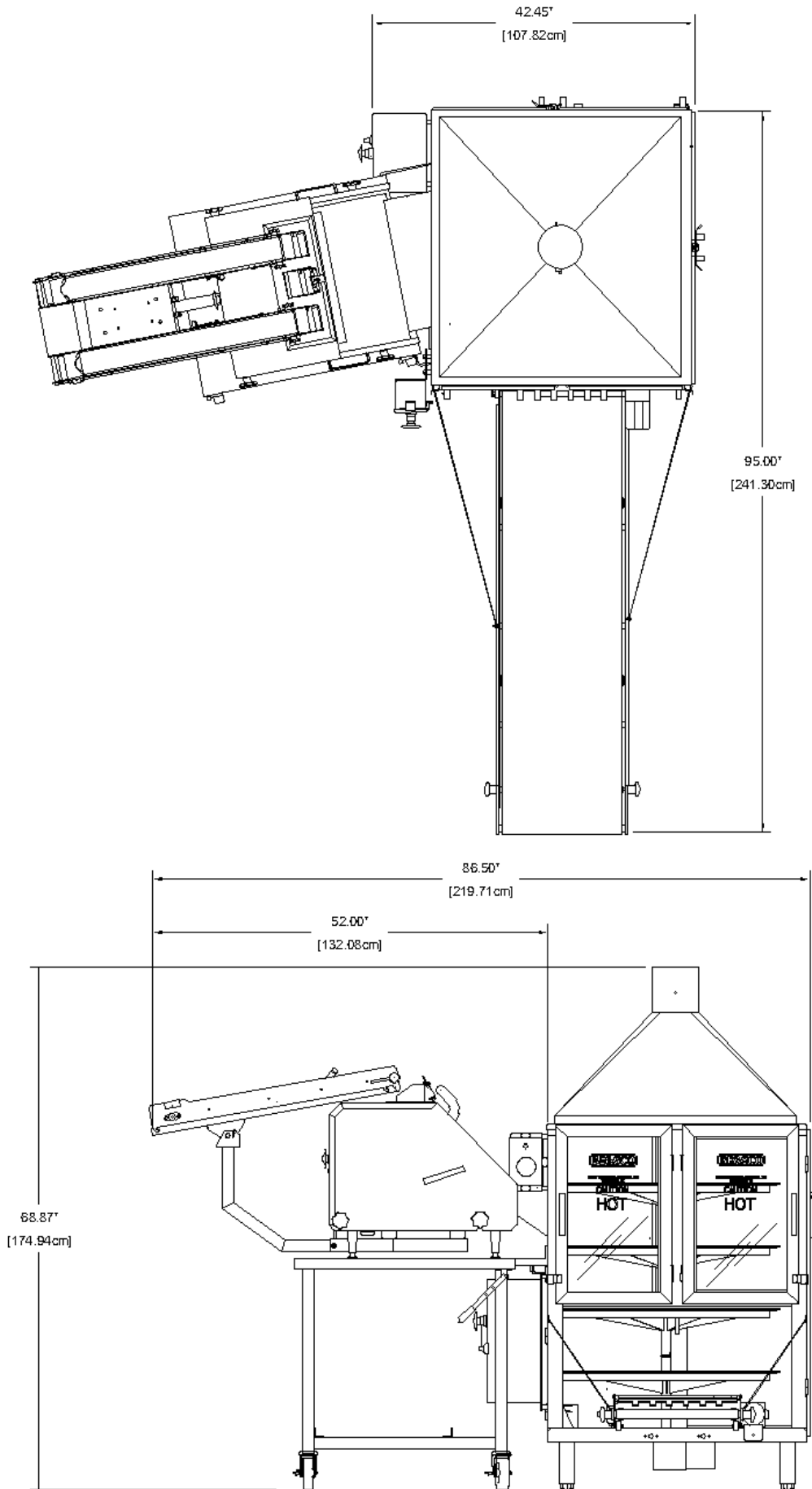

Grandemax Combo, Right Exit

Model: 20RX-13, 12L, 29AS

(Shown with Model 78 DTL and 30" Exit Conveyor)

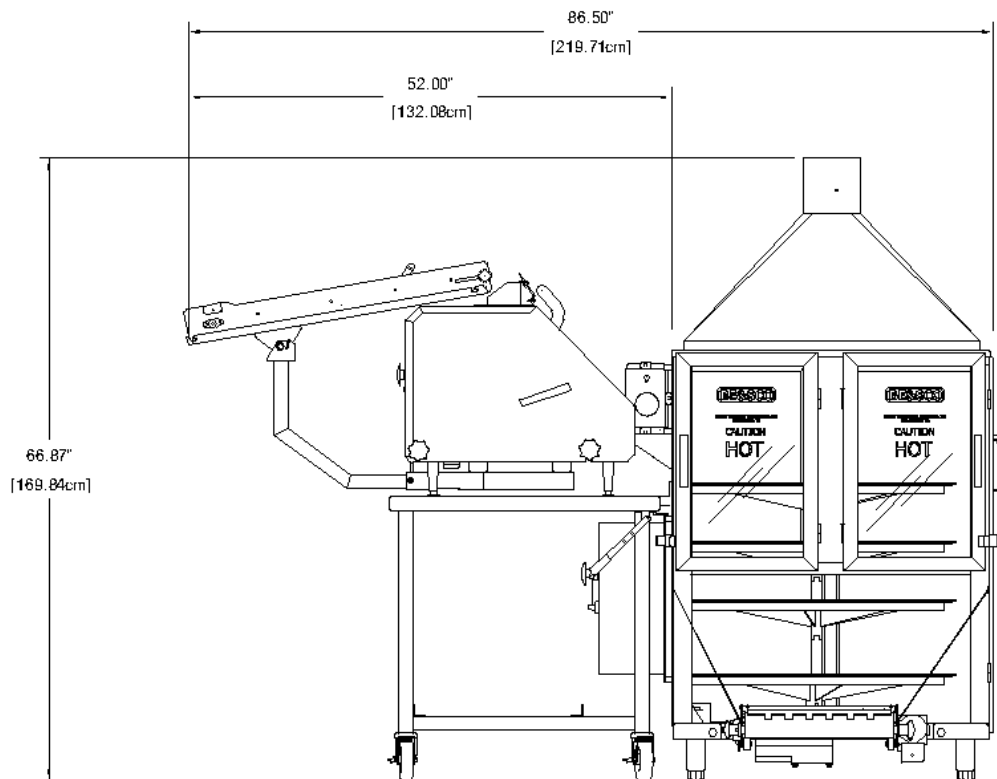
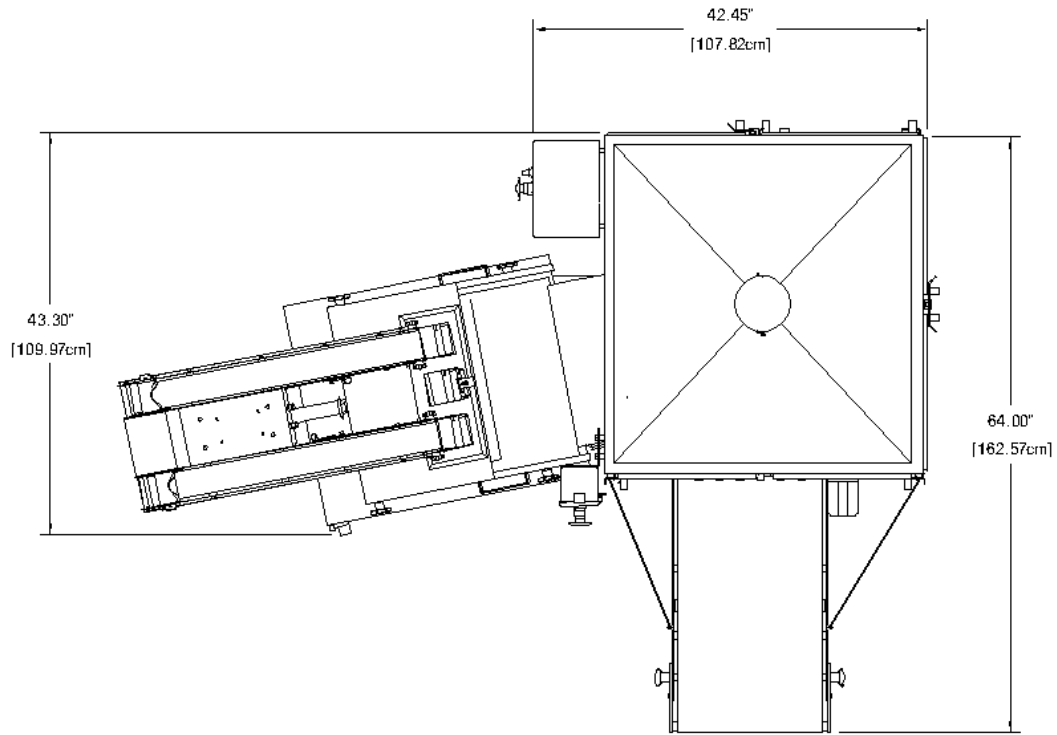

Grandemax Combo, Right Exit

Model: 20RX-13, 12L, 29AS

(Shown with Model 78 DTL and 42" Exit Conveyor)

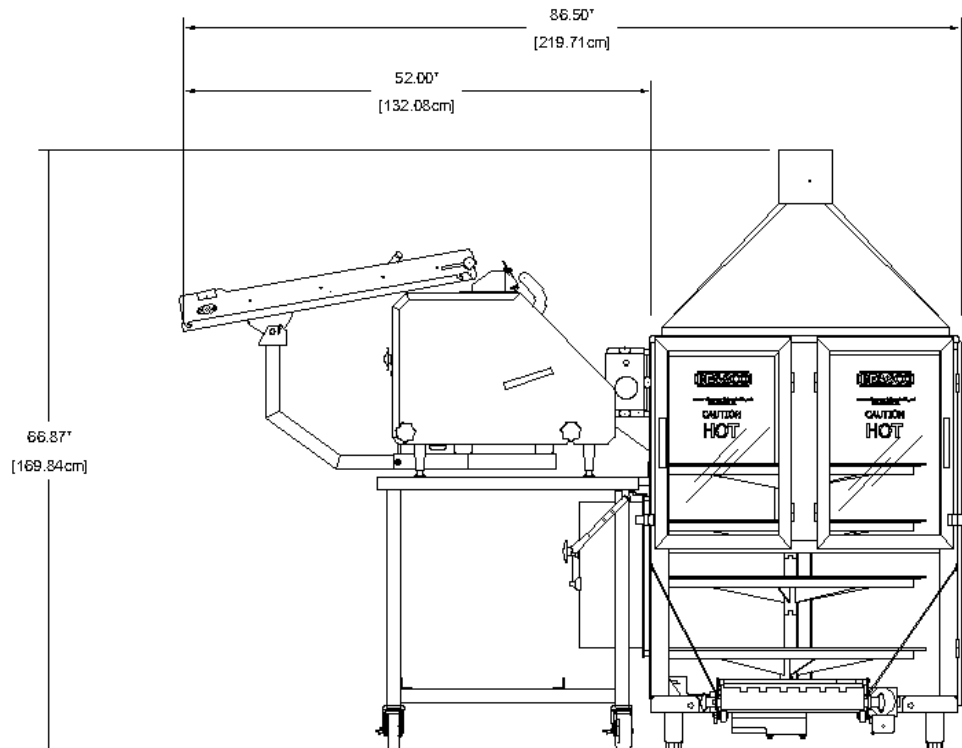
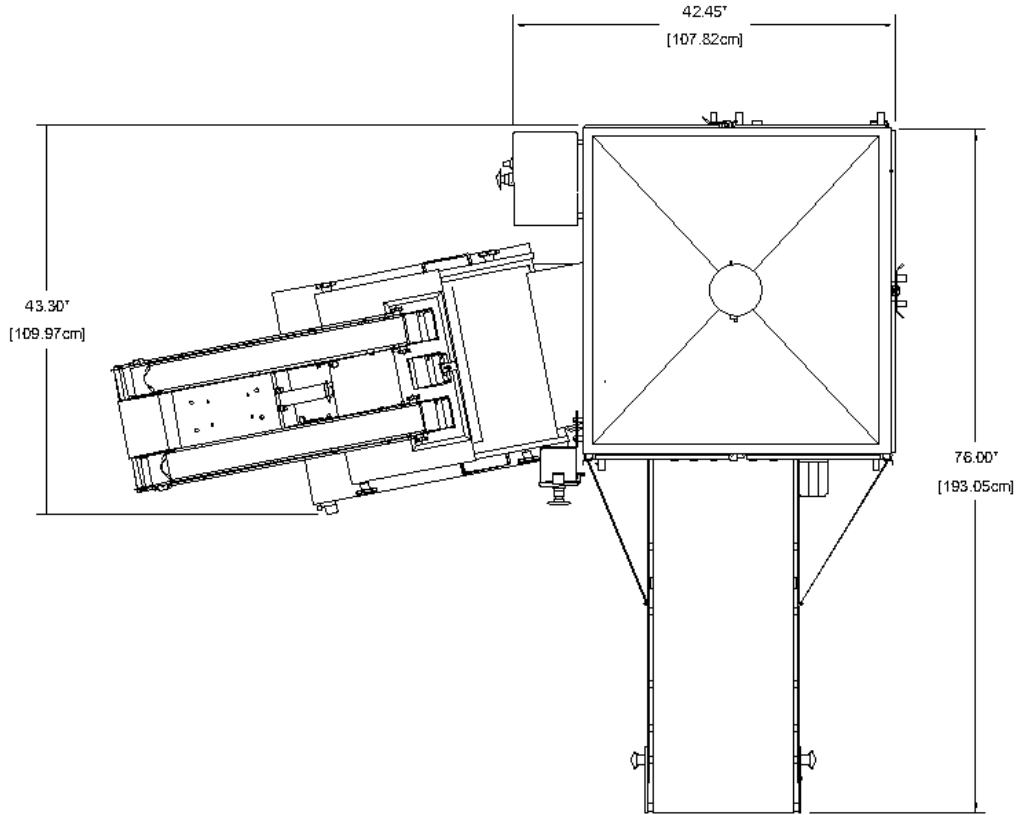

Grandemax Combo, Right Exit

Model: 20RX-13, 12L, 29AS

(Shown with Model 78 DTL and 42" Exit Conveyor)

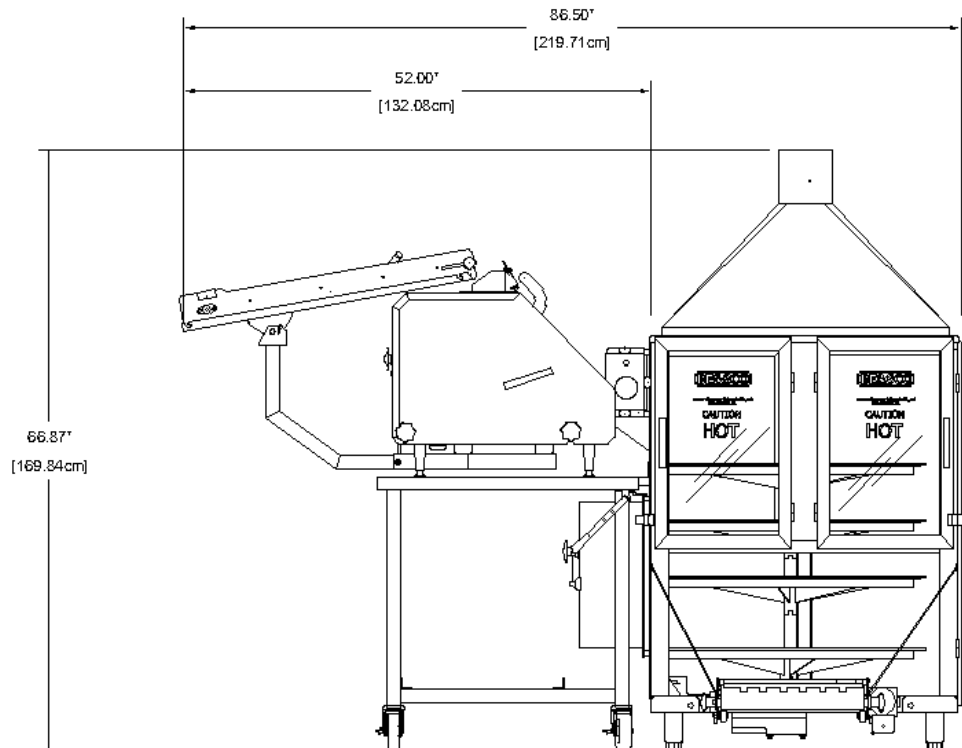
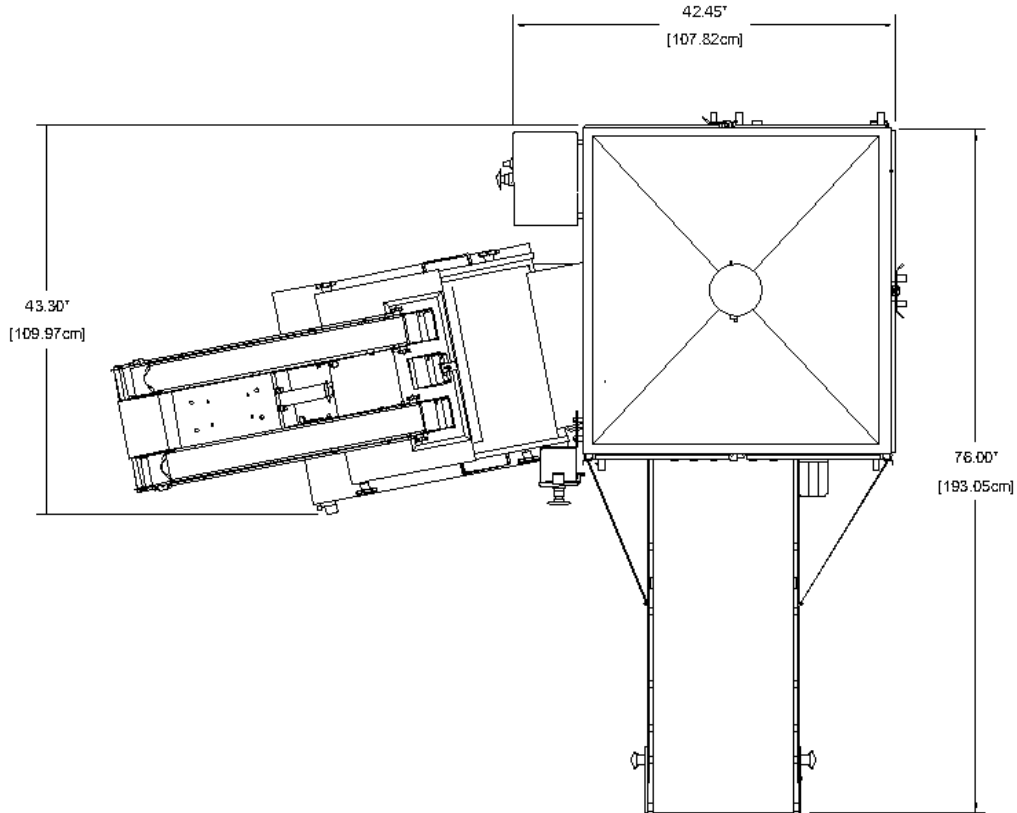

Grandemax Combo, Right Exit

Model: 20RX-13, 12L, 29AS

(Shown with Model 78 DTL and 60" Exit Conveyor)

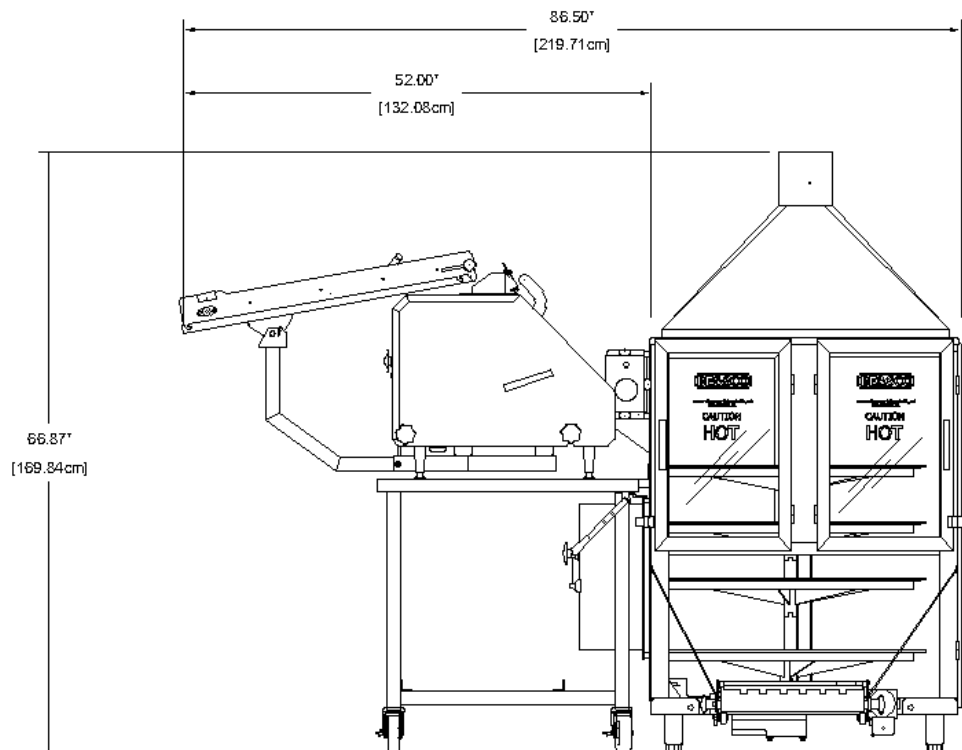
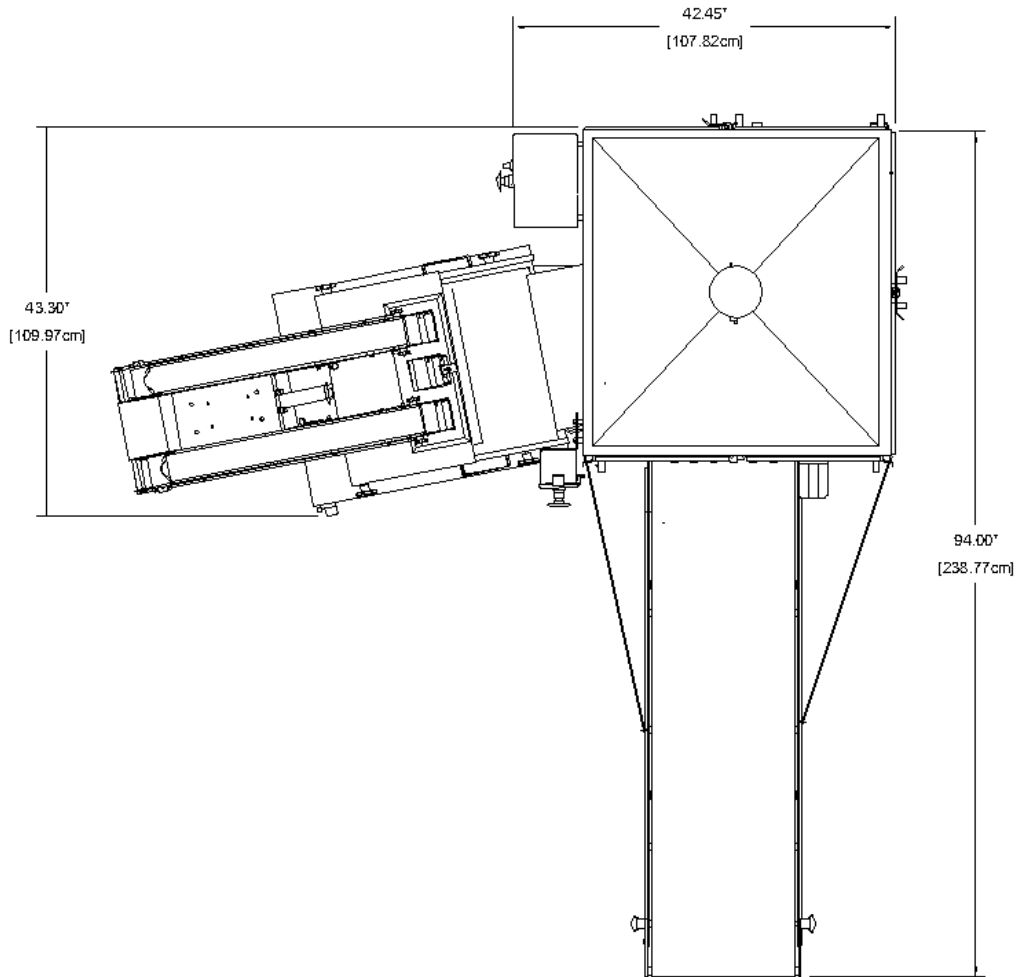

Grandemax Combo, Right Exit with Return Conveyor - Model: 20RX-13, 12L, 29AS

(Shown with Model 78 DTL, 42" Exit Conveyor & Return Conveyor)

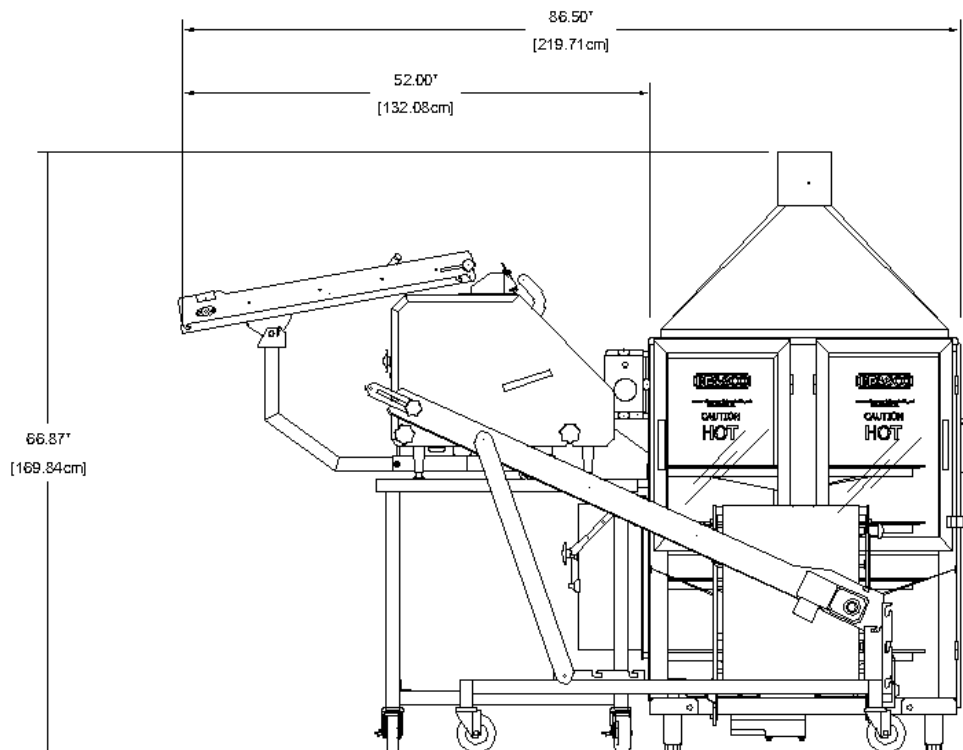
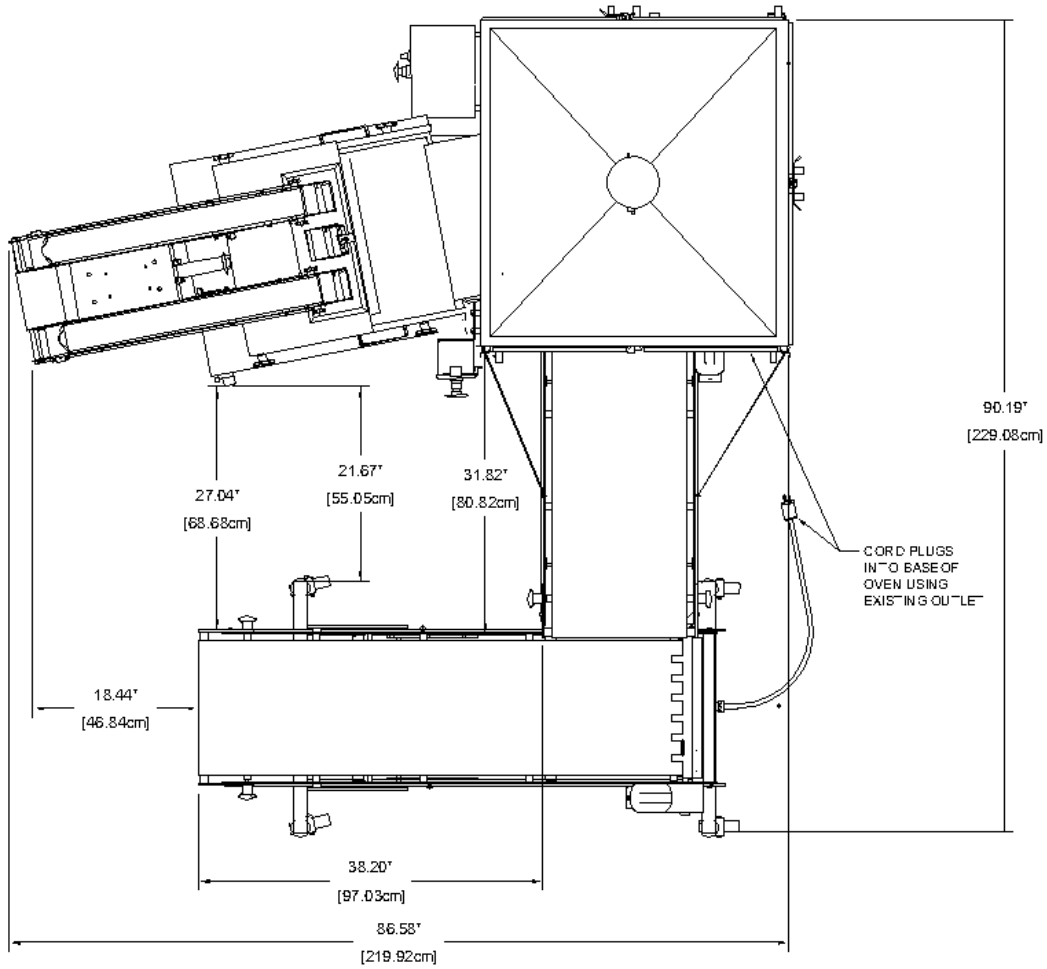

Grandemax Combo, Right Exit with Return Conveyor - Model: 20RX, 12L, 29A

(Shown with Model 78 DTL, 42" Exit Conveyor & Return Conveyor)

