



Project \_\_\_\_\_  
 AIA # \_\_\_\_\_ SIS # \_\_\_\_\_  
 Item # \_\_\_\_\_ Quantity \_\_\_\_\_ C.S.I. Section 114000

## R-Series

Dual Temp Refrig./Heated Reach-In Model  
 32" Deep, Self-Contained



### STANDARD PRODUCT FEATURES

- Heated Top Cabinet, Refrigerated Bottom Cabinet
- Traulsen's Smart Control with LED Display
- Stainless Steel Exterior & Interior
- Balanced, Self-Contained Refrigeration System Using R-450A
- Half-Height Stainless Steel Doors with Locks
- Self-Closing Doors with Stay Open Feature at 120 Degrees
- Standard Door Hinging: 132W = Right (other hingings available)
- Automatically Activated LED Lights
- Stainless Steel Breaker Caps
- Adjustable, Coated Wire Shelves (factory installed)
- Magnetic Snap-In EZ-Clean Door Gaskets
- Gasket-Protecting Raised Door Liners
- Thermostatic Expansion Valve Metering Device (refrigeration system)
- Stainless Steel One-Piece Louver Assembly & Heater Guards
- 9' Cord & Plug Attached
- Set of (4) 6" High Adjustable Stainless Steel Legs

### ACCESSORIES & OPTIONS

- Stainless Steel Finished Back with Rear Louvers
- Rehinging Feature for Doors
- #1 Type Trayslides to Accommodate either (1) 18" x 26" or (2) 14" x 18" Sheet Pans
- Universal Type Trayslides to Accommodate Either (1) 18" x 26", (2) 14" x 18" Sheet Pans, or (2) 12" x 20" Steam Table Pans
- Additional Coated Wire or Optional Stainless Steel Shelves
- Stainless Steel Banking Strip
- Locking Hasps (padlocks supplied by others)
- Export 220/50/1
- Kool Klad Exterior Laminate Decor (consult factory)
- Set of (4) 4 1/8" or 6" High Casters in Lieu of Legs
- 6" Stainless Steel Flanged Legs
- Other Support Options: 4 1/2" High Base or 6" High Kickplate (for use with standard legs)
- Clear Glass Doors in Place of Solid Doors
- Heat Shield
- Contact Factory for Prison/Correctional Facility Options



This unit is listed to the applicable UL, CSA and NSF Standards by an approved NRTL. Consult the factory or unit's data plate for approval information.

### AVAILABLE CONFIGURATIONS

**R-Series Models**  
 RDH132WUT-HHS

**Door(s)**  
 Half Height Solid

**Hinging**  
 Right

**- GUARANTEED FOR LIFE CAM-LIFT HINGES  
 - GUARANTEED FOR LIFE HORIZONTAL WORK  
 FLOW DOOR HANDLES (SOLID DOORS ONLY)**

Approved by \_\_\_\_\_ Date \_\_\_\_\_ Approved by \_\_\_\_\_ Date \_\_\_\_\_



# R-Series

Dual Temp Refrig./Heated Reach-In Model  
32" Deep, Self-Contained

## MODEL

RDH132WUT-HHS

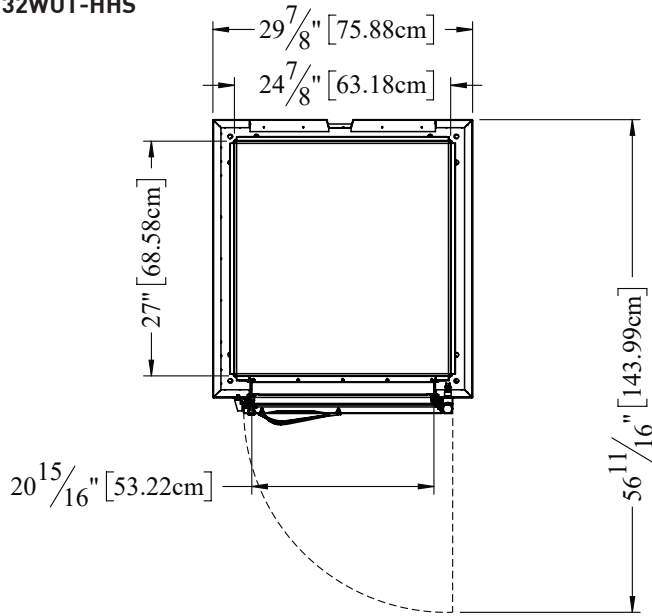

TOP VIEW

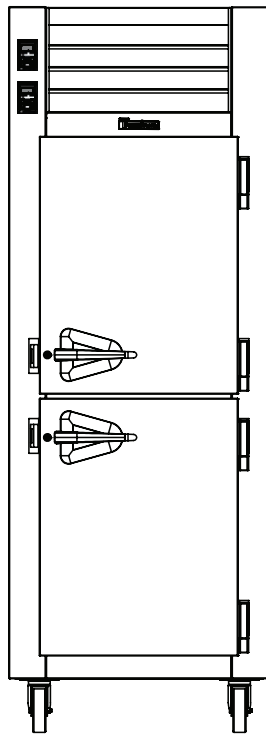

ELEVATION

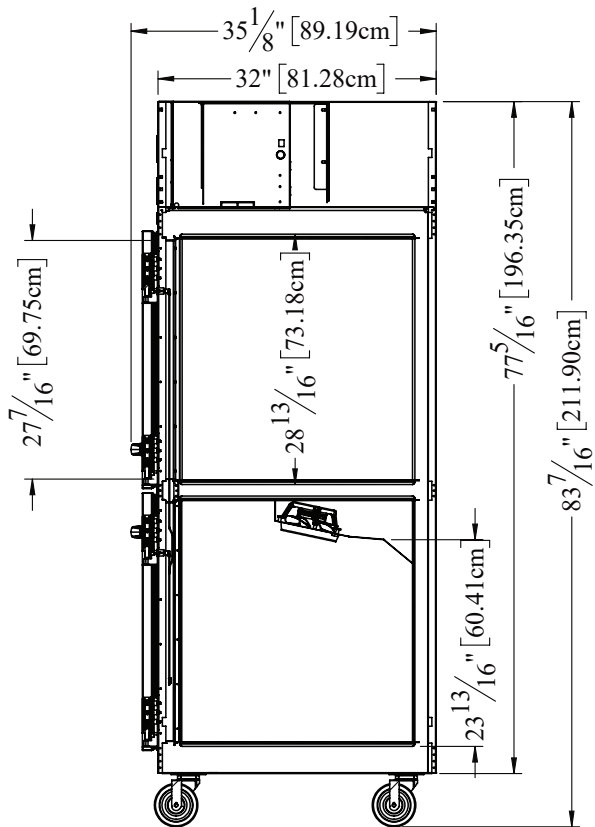

SIDE VIEW

> CAD and/or Revit Files Available

<https://traulsen.klccad.com/>



### MODEL

RDH132WUT-HHS

MODELS	RDH132WUT
<b>DIMENSIONAL DATA</b>	
Net capacity cu. ft.	22.3 (631.5 cu l) [11.5 per cabinet]
Length - overall in.	29 7/8" (75.9 cm)
Depth - overall in.	35 1/8" (89.2 cm)
Depth - over body in.	32" (81.3 cm)
Depth - door open 90° in.	56 11/16" (144 cm)
Clear door width in.	20 15/16" (53.2 cm)
Clear half-door height in.	27 7/16" (69.8 cm)
Height - overall on 6" legs <sup>2</sup>	83 7/16" (211.9 cm)
No. Standard Shelves	2
Shelf area total sq. ft. <sup>3</sup>	8.43 (0.78 sq m)
Shelf area refrigerator sq. ft. <sup>3</sup>	4.21 (0.39 sq m)
Shelf area heated cabinet sq. ft. <sup>3</sup>	4.21 (0.39 sq m)
<b>ELECTRICAL DATA</b>	
Voltage   Plug	208-230/115/60/1   NEMA L14-20P
Wattage @ 208V	1000
Full Load Amperes   MDEC <sup>4</sup>	11   1.82 kWh/Day
<b>REFRIGERATION DATA</b>	
Refrigerant	R-450A
Refrigerant Charge Amount oz.	11 (311.84 g)
BTU/HR   H.P. <sup>1</sup>	2220   1/3 HP
<b>SHIPPING DATA</b>	
Length - Crated in.	48" (121.9 cm)
Width - Crated in.	42" (106.7 cm)
Height - Crated in.	85" (215.9 cm)
Volume - Crated cu. ft.	99.17 (2808.2 cu l)
Weight - Crated lbs.	557 (252.7 kg)

**NOTES:** Figures in parentheses reflect metric equivalents.

1. Based on a 90°F ambient and 20°F evaporator.
2. 12" Top clearance preferred for optimum performance & service access.
3. Area of standard shelf compliant only, does not include storage area of additional shelves or available on cabinet bottom.
4. MDEC = Maximum Daily Energy Consumption

When ordering please specify: Voltage, Hinging, and Options.

Equipped with one NEMA L14-20P Plug



### EQUIPMENT SPECIFICATIONS

#### CONSTRUCTION, HARDWARE, INSULATION

Cabinet exterior front, one piece sides, louver assembly & door is constructed of heavy gauge stainless steel with #4 finish. Cabinet interior & door liners are also constructed of stainless steel. The exterior cabinet top, back & bottom are constructed of heavy gauge galvanized steel. A set of four (4) adjustable 6" high stainless steel legs are included.

Doors are equipped with a gasket-protecting metal door pan, removable plug cylinder locks & guaranteed for life cam-lift, gravity action, self-closing metal, glide hinges with stay open feature at 120 degrees. Hinges include a switch to automatically activate the interior LED lighting. Guaranteed for life, work flow door handles are mounted horizontally over recess in doors which limit protrusion from door face into aiseways. Doors have seamless, polished metal corners.

Gasket profile & EZ-Clean material simplify cleaning & increase overall gasket life. Anti-condensate heaters are located behind the door opening of the refrigerated cabinet. Both the cabinet & door is insulated with an average of 2" thick high density, non-CFC, foamed in place polyurethane.

#### SELF-CONTAINED REFRIGERATION SYSTEM (BOTTOM)

A top-mounted, self-contained, balanced refrigeration system using environmentally friendly, non-flammable R-450A refrigerant is conveniently located behind the one piece louver assembly. These models feature an easy to clean front facing condenser, thermostatic expansion valve, air cooled hermetic compressor, large, high humidity evaporator coil. A 9' cord & plug is provided standard. Standard operating temperatures are 34-38°F for the refrigerator compartment.

#### SELF-CONTAINED HEATING SYSTEM (TOP)

A low watt density, serpentine style, heater is employed for the generation of electric heat. Low velocity air is forced across its large surface area to efficiently move heat radiating away from these through a down-air distribution duct, where it is then evenly distributed through the cabinet, assuring the proper holding environment for hot food product, without drying. A vent, located at the top of the cabinet, is included for positive humidity control. Standard operating temperatures are 140-180°F for the heated compartment.

#### CONTROL

Traulsen's Smart Control features advanced control algorithms & sophisticated diagnostic capabilities to optimize performance. Utilizing Smart Sensors, it adapts the operation of the refrigeration and heating systems to a variety of environments & usage patterns. The Smart Control also offers a complete set of visual alarms designed to alert the user to critical events such as power outages or a prolonged door opening. In the event of an alarm, a dedicated Alarm LED will illuminate, informing the user of the critical event and duration.

#### INTERIOR

Standard interior arrangements include one (1) coated wire shelves per cabinet, mounted on pilasters (heated cabinet) & pins (refrigerated cabinet). Shelves are full-width & do not have any large gaps between them requiring the use of "bridge" or "junior" shelves. Recommended load limit per shelf should not exceed 225 lbs. Optional trayslides may be purchased in combination with, or in lieu of these. Interior arrangements are factory-installed.

#### WARRANTY

Both a six year parts and labor warranty and a seven year compressor warranty (self-contained models only) are provided standard.

CONTINUED PRODUCT DEVELOPMENT MAY NECESSITATE SPECIFICATION CHANGES WITHOUT NOTICE.