

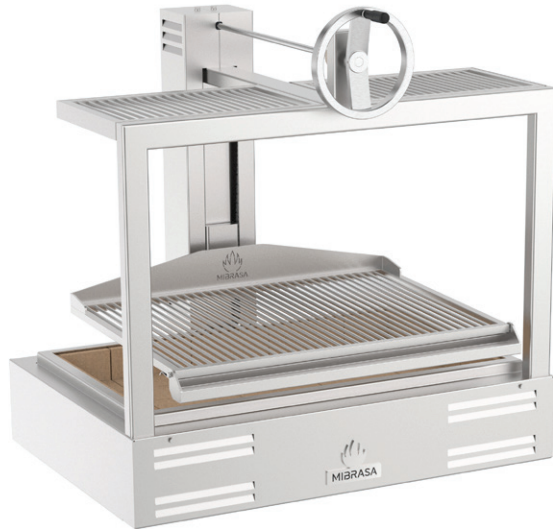

Project: _____ Item# _____

Parrilla GMB 100



TECHNICAL INFORMATION

Fire up time ¹	30 min-average	
Cooking temperature	482 °F	250 °C
Total cooking surface area	35.04" x 24.8"	890 x 630 mm
Grill height range (in/mm)	13.78"	350 mm
Initial charcoal load ¹	22 lb	10 kg
Charcoal load duration ²	5 h	
Equivalent power*	6 hp	4.5 kW
Exhaust rate	300 gal/s	4100 m ³ /h
Installation height*	27.56"	700 mm
Net weight ³	584.2 lb	265 kg
Crated weight* ³	826.7 lb	375 kg
Crated size (WxDxH)	44" x 52" x 55"	1120 x 1310 x 1380 mm

FEATURES

Precision and strength is key to the PARRILLA by MIBRASA®. Effortlessly regulate the height of your grill surface thanks to the carefully engineered sprocket and chain system, keeping maintenance down to a minimum.

The system lets us sear, cook and rest our ingredients, to get the optimal result every time.

ERGONOMICALLY DESIGNED WITH MAXIMUM QUALITY AND SECURITY

With a sloping grill, the grease runs down the weld-free grill bars to prevent grease build-up. Grease drips down to the collector with an easy to remove mechanism ready to clean.

The base is lined with refractory bricks to ensure maximum heat efficiency and resistance to pure fire. And the built-in cooling system in outer case guarantees a maximum level of security.

Built using quality steels providing strength and durability; ergonomically designed for practicality and ease of use, each feature plays a crucial part in delivering the ultimate grilling machine for every chef.

*Approximate data

1. Consult instruction manual
2. Will vary depending on quality of charcoal
3. Weight with accessories included

INCLUDED ACCESSORIES

- Rod grill [CPV100]
- Ash shovel [PALA]
- Ember poker [PK]
- Mibrasa tongs [TG]
- Grill brush [CEP]

OPTIONAL ACCESSORIES

- V-shape grill [GV100]
- Extra rod grill [CPV100]
- Burning pit lid [TAPA85]
- Thermal protector [EPGMB100]
- Espeto skewer kit [KITESPGMB100]
- GN support kit [SGN100]

Specifications and design are subject to change without notice.

QUALITY GUARANTEE





Parrilla GMB 100

FRONT VIEW

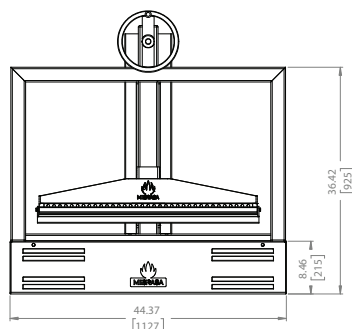

SIDE VIEW

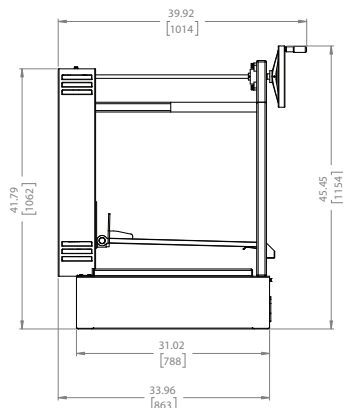

TOP VIEW

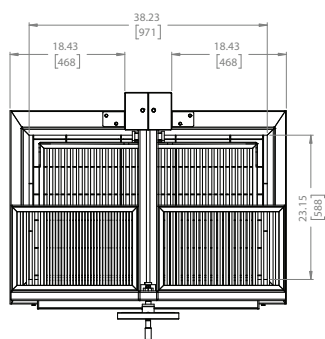

Dimensions in inches and [mm]

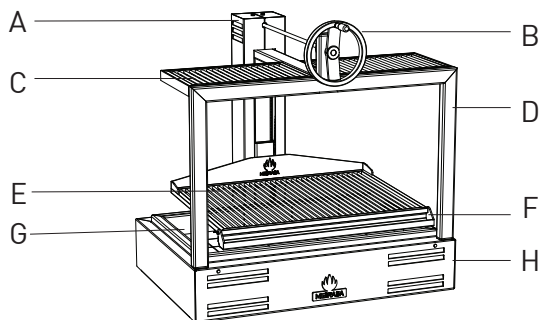

A	Elevating system
B	Elevating wheel
C	Heating rack
D	Structure
E	Grill
F	Grease collector
G	Refractory bricks
H	Main body

GRILL TYPES

Rod bar grill

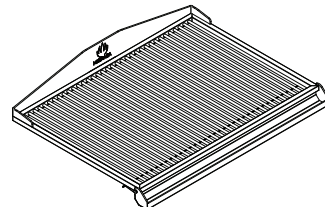

V-shape grill

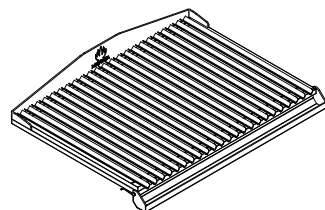

GRILL DIMENSIONS

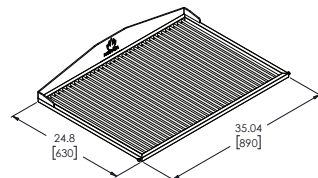

HEATING RACK DIMENSIONS

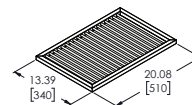

Revit drawings available on request at usa@mibrasa.com

Safety standards and installation guidelines

- Combustible floor protection dimensions:
 - a. 30 in [762 mm] to each side of the Parrilla
 - b. 36 in [914 mm] in front of the Parrilla
- Clearances to combustibile construction/other appliances:
 - a. Unit to backwall = 7 in [180 mm]
 - b. Unit to sidewalls = 28 in [720 mm]
- The workspace for the chef should be 27.56 in [700 mm] from the front of the Parrilla.
- A lifting device should be used whenever possible to lift the Parrilla and place on the countertop/stand.

For further information, please consult the instruction manual.

Specifications and design are subject to change without notice.



Parrilla GMB 100

OPTIONAL COMPLETE STAND



TECHNICAL INFORMATION

Ref.	GMB100 + MCGMB100	
Net weight ³	769.4 lb	349 kg
Crated weight* ³	1012 lb	459 kg
Crated size (WxDxH)	44" x 52" x 85"	1120 x 1310 x 2150 mm

Ref.	MCGMB100	
Net weight ³	185.2 lb	84 kg
Crated weight* ³	218.3 lb	99 kg
Crated size (WxDxH)	44" x 52" x 28"	1120 x 1310 x 700 mm
No. drawers	3	
No. GN rack slots	5	

OPTIONAL ACCESSORIES

- S/S Casters [WINOXG]

FRONT VIEW

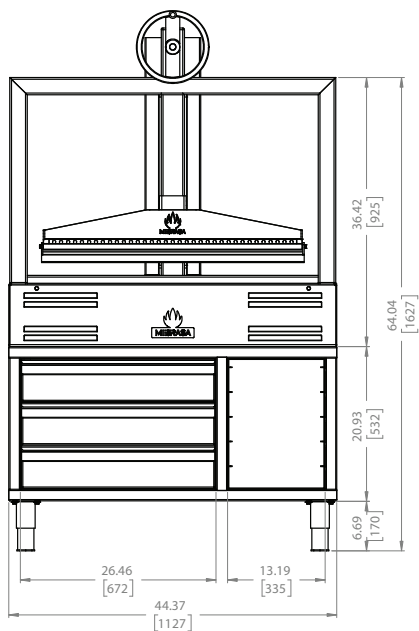

SIDE VIEW

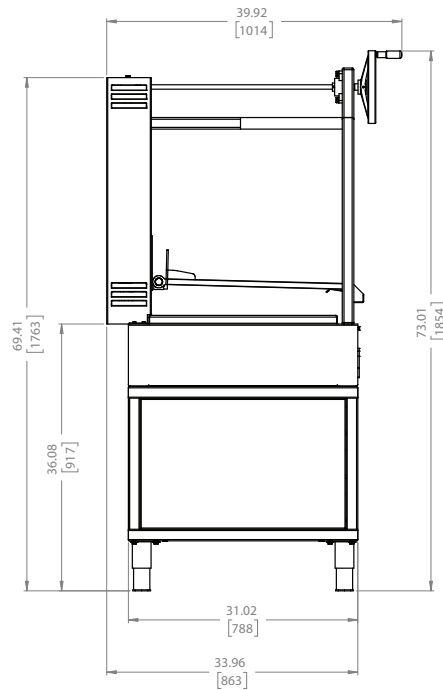

Dimensions in inches and [mm]