

GEM R4-S3

Fish Showcase

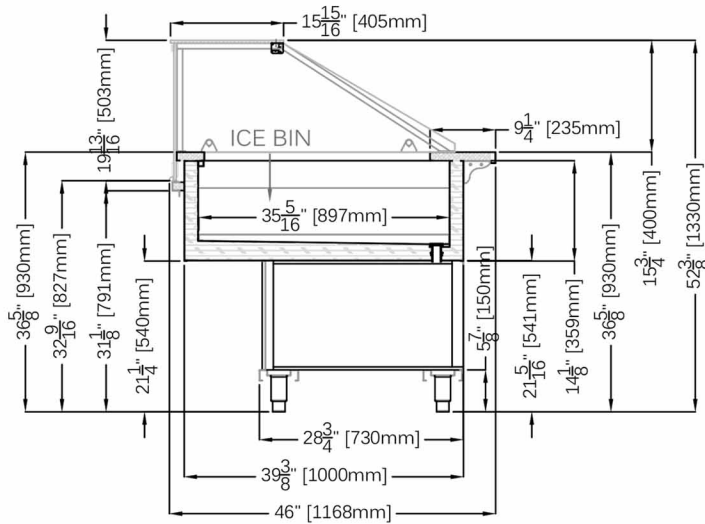

STANDARD FEATURES

- LED lighting
- Extra clear glass upper structure
- Plexiglas sliding glass back doors
- Stainless steel cold wall static cooling insulated bin to retain ice
- Insulated stainless steel interior AISI 316 anti-corrosion
- Built in drain for cleaning
- Floor sink is required
- Cases ship standard unfinished

OPTIONS

- Matching Rosa
- Hot water flush out piped in body
- Gem G1: sliding glass back doors on the operating side. Lift up top glass on the customer side
- RAL color/laminate front and side panels
- Casters

PLAN VIEWS

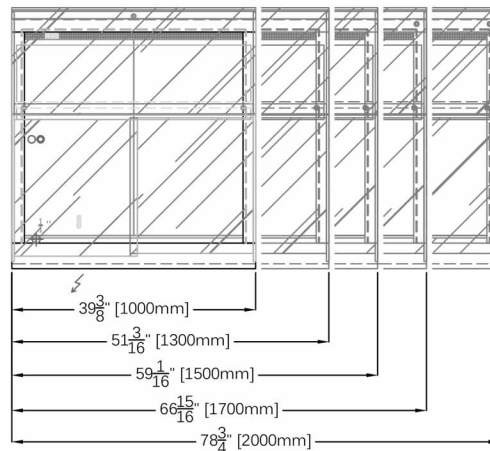

A90

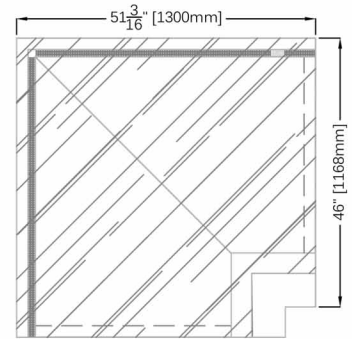

GEM R4-S3 FISH							
TECHNICAL FEATURES		MODELS					
		GEM R4-S3 F1000	GEM R4-S3 F1300	GEM R4-S3 F1500	GEM R4-S3 F1700	GEM R4-S3 F2000	GEM R4-S3 FA90
External Dimensions (L-D-H)	Inches	39 3/8" - 46" - 52 3/8"	51 3/16" - 46" - 52 3/8"	59 1/16" - 46" - 52 3/8"	66 15/16" - 46" - 52 3/8"	78 3/4" - 46" - 52 3/8"	51 3/16" - 46" - 52 3/8"
	Inches-MM	1000 - 1168 - 1330	1300 - 1168 - 1330	1500 - 1168 - 1330	1700 - 1168 - 1330	2000 - 1168 - 1330	1300 - 1168 - 1330
Crated Dimensions (L-D-H)	Inches	45" - 52" - 58 1/8"	57" - 52" - 58 1/8"	67" - 52" - 58 1/8"	74 3/4" - 52" - 58 1/8"	84" - 52" - 58 1/8"	57" - 52" - 58 1/8"
	Inches-MM	1150 - 1320 - 1476	1447 - 1320 - 1476	1700 - 1320 - 1476	1900 - 1320 - 1476	2150 - 1320 - 1476	1447 - 1320 - 1476
Operating Temperature	°F	36°F	36°F	36°F	36°F	36°F	36°F
BTU'S @ +14°F Evap Temperature	BTU'S	2200 BTU'S	2900 BTU'S	3600 BTU'S	3800 BTU'S	3100 BTU'S	3100 BTU'S
Electric Supply	(V/Ph/Hz)	120/1/60	120/1/60	120/1/60	120/1/60	120/1/60	120/1/60
Power Consumption	(A)	8A	10A	11A	12A	14A	14A
Net Weights	Kg/Lb	120Kgs / 264Lbs	135Kgs / 298Lbs	158Kgs / 348Lbs	187Kgs / 412Lbs	202Kgs / 445Lbs	260Kgs / 572Lbs
Crated Weights	Kg/Lb	150Kgs / 330Lbs	165Kgs / 364Lbs	180Kgs / 388Lbs	217Kgs / 478Lbs	235Kgs / 518Lbs	310Kgs / 674Lbs

* DIMENSIONS ARE WITHOUT SIDE PANELS

* Manufacturer reserves the right to change specifications without notice. Not responsible for error and omissions.



512 South Airport Blvd., South San Francisco, CA 94080
 Tel: 855.885.2400 | 650.342.2400 | Fax: 650.342.7400
 sales@oscartek.com | www.oscartek.com

