

300-5070

SprayMaster
TECHNOLOGIES

1100SS POWER CLEAN GO



FEATURES

- Adjustable Pressure Unloader, 150° / 65.5°C Max Water Temp
- Powder Coated Gun Hanger
- Hose / Cord Hanger
- Chemical Hanger
- Adjustable Single Chemical Injection
- 35 ft GFCI Power Cord
- 30 ft Steel Braided High Pressure Hose
- 36 in Stainless Spray Gun & Wand Assembly
- General, Triplex Plunger Pump
- Industrial 2HP Totally Enclosed, Fan Cooled Motor
- 120vAC / 60Hz / 20A
- 1100 PSI / 2.1 GPM



(800) 548-3373
www.spraymastertech.com

115 E Linden • Rogers, Arkansas 72756 USA
Office: (479) 636-5776 • Fax: (479) 636-3245



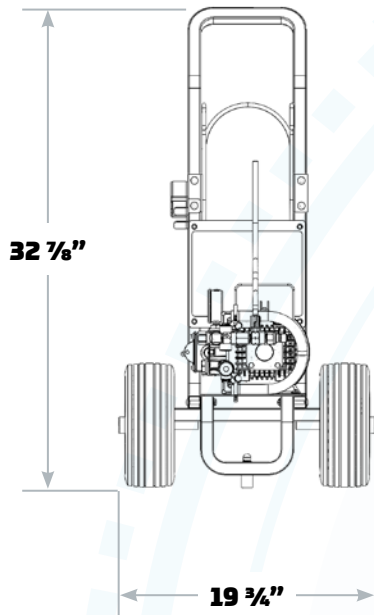

FRONT VIEW

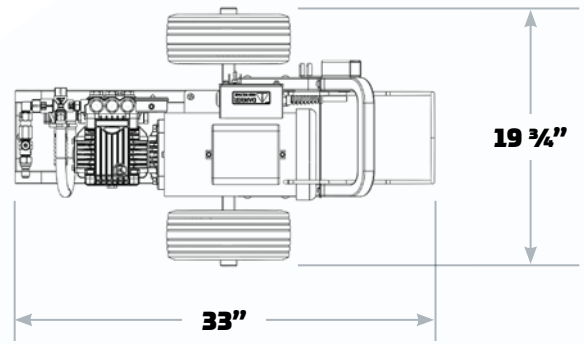

TOP VIEW

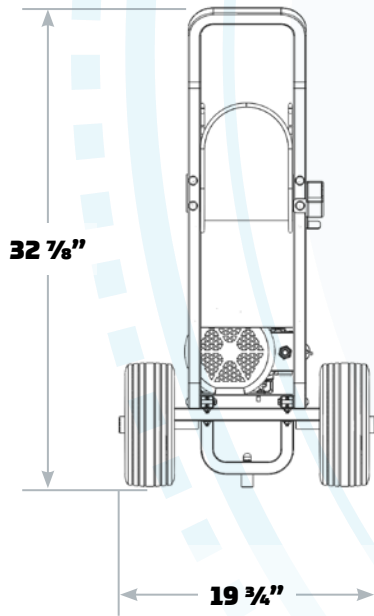

BACK VIEW

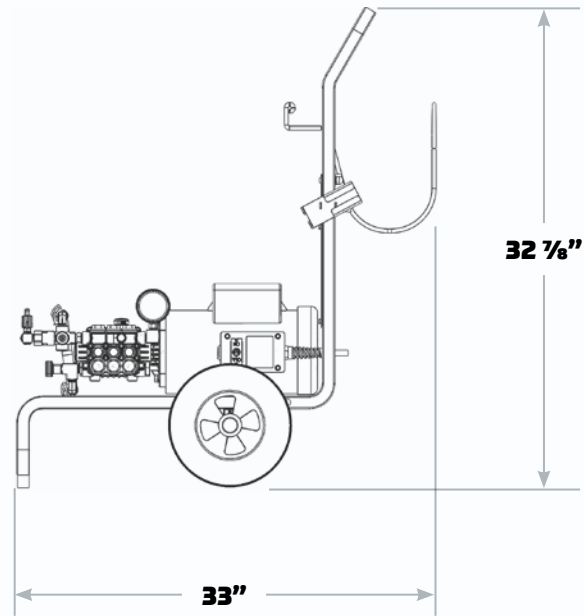

SIDE VIEW

EQUIPMENT SPECIFICATIONS

Plumbing

3/4" / 2cm Hose Bib with 5 gpm / .14 Lpm @ 30psi / 20.6 bars. 150°F / 65.5°C

Electrical

120v AC, 60Hz, 20A dedicated circuit