

ITEM #



# ELECTRIC Series

## Stackable Electric Oven

### ELST73-44/1

Designed and manufactured with efficiency, durability, and modularity in mind, the stackable electric ovens achieve high-volume cooking and baking production through vertically integrated modular oven decks to reduce kitchen footprint. These electric deck ovens are available in 4 configurations, and are able to be vertically stacked up to four-decks in height. With temperatures ranging between 200° and 950°F, these versatile ovens are ideal for high-volume pizza making as well as Artisan baking and traditional cooking. The ovens can be configured as multi-deck ovens using a common chassis, or independently stacked as needed based upon production demand.

These ovens feature a large illuminated cooking area designed to maximize baking capacity. A manually controlled vent on each deck allows for humidity evacuation from the oven cavity as needed by application. Large full-width windowed doors are supported by a heavy duty coil spring for durability and ease of use. Featuring the digital control touchscreen, each oven cavity operates using high-efficiency radiant heating technology located within brick deck plates maximizing thermal control independently for best baking results.



### Standard Features

- 304-gauge stainless steel exterior front and doors. Galvanneal interior and sides.
- Full width front hinged door features a large recessed tempered glass window for high visibility of internal cooking chamber.
- Large insulated full-length safety door handle to prevent injury when opening and closing the door.
- Independently controlled upper and lower radiant heating allows precision temperature control and finished quality of food.
- Oven decks feature independent touch screen controls, allowing different operating temperatures within the stacked configuration.
- Proprietary MarraStone® refractory brick deck is 1½" thick and highly porous, designed to maintain temperatures greater than 1000°F for consistent high-volume production.
- Cooking cavity is designed to accept side by side 18"x 26" full-size sheet and baking pans.
- Ovens are controlled individually with MarraSmart® digital touch screen control technology, which is programmable and provides complete control of oven cooking conditions.
- 200° – 950°F cooking temperature range.
- Standard with interior lighting and manually controlled damper vent allows operator to evacuate humidity from the cooking chamber.
- 7" interior cook deck height
- Oven decks require individual dedicated electrical connections.
- Manufactured in the U.S.A
- 1-year parts and labor warranty.
- Approved for use with direct ventilation.

### Cooking Capacity (Per Deck)

- 8" Pizzas: 45
- 10" Pizzas: 28
- 12" Pizzas: 18
- 16" Pizzas: 8
- 20" Pizzas: 6

**Total Cooking Surface: 22.26 Square Feet**  
(cooking deck 73.0" x 44.0")

Production capacity varies depending upon type of food product being cooked, set temperatures and preparation methods used.

### Configuration Options (Check all that apply)

#### Required

- Top Mounted Ventilation Cap (Part #ESVC73-44)
- Mobile Steel Stand - Matte Black (Part #ESSSS73-44/1) (includes 5" locking casters)

#### Options

- Direct Ventilation (Quoted Separately)
- Exhaust Fan
- Additional Modular Cooking Deck (Requires additional dedicated electrical connection)
- Base Tray Slides (51 sets on 2" spacing)

#### Accessory Items

- Dough Tray
- Dough Tray Lids
- Dough Tray Dolley
- Deluxe Peel Tool Kit
- Standard Peel Tool Kit
- Wall Mounted Tool Rack



ANSI Z83.11 CSA 1.8

# ELECTRIC Series

Stackable Electric Oven

ELST73-44/1

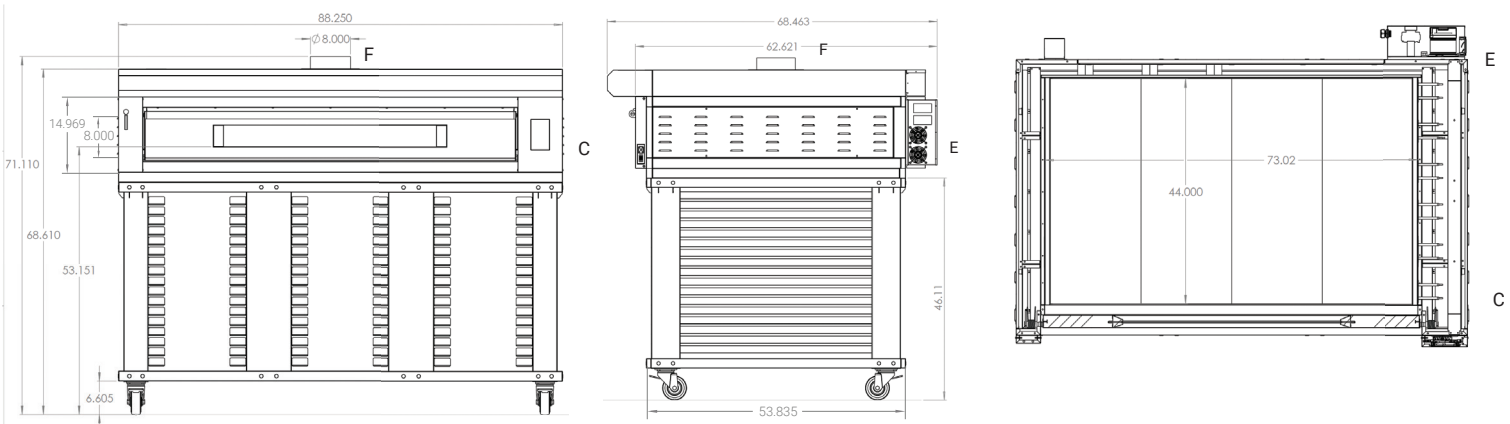

\*optional tray slide kit

- C - Controls
- E - Electrical Connection Flexible Cord
- F - Flue Collar

## Venting Requirements

- The oven is vented through an 8" round duct collar.
- Ovens can be installed with a UL listed exhaust hood system or approved direct vent exhaust duct vented outside. Must be installed with a power exhausted vent.
- Cubic Feet per Minute: 150 CFM (per cooking deck)
- Static Pressure: 0.01" W.C.
- Ventilation is subject to local jurisdictional approval

## Clearance Requirements

- 2" minimum clearance on all sides
- 0" clearance required on rear, must allow for utility connections

## Dimensions Model ELST73-44/1

- Exterior (H x W x D): 68.61" x 88.25" x 68.46"
- Shipping (H x W x D): 88.00" x 104.00" x 76.46"
- Weight: 2,150 lbs. Crated Weight: 2,700 lbs.
- Freight Class: 77.5 Shipped LTL

## Electrical Connection Requirements (Per Deck)

Region	Voltage	Hz	Amp	kW	Phase	Supply	Power Supply
North America	208V	50/60	60	20.6	3	4-wire	Rear, right side

Each oven cavity requires a separate dedicated electrical connection.

Due to ongoing product development and continuous improvement measures, specifications are subject to change without notice. All ovens are designed for commercial applications.

