



HEATED FRY DUMP STATION

For Bulk Holding of Fried Items in 12"x 20" Pans

RADIANT "HMC-FD" SERIES

Holds crispy fried foods at optimal serving temperature in bulk or ready-to-grab individual portions - perfect for salt, scoop, & bag preparation

- 1** Ceramic, long wave, infrared elements heat up in under 10 minutes, and keep fried foods at optimal serving texture and temperature
- 2** Industry standard 12" x 20" x 4" hotel pans serve as a catch basin and are easily removable and replaceable
- 3** Simple, side-mounted on/off controls with indicator light
- 4** For models with multiple pans, a removable well insert goes between the pans, keeping the well clean
- 5** Elevated pan insert keeps food at optimal distance from heating element

- 6** Easily hold multiple products in one pan with provided removable divider
- 7** Field reversible, stainless side heat shield keeps food secure and surrounding workspace clean
- 8** Bagged product storage bin assists when assembling batches of product
- 9** Convenient storage shelf for condiments and food service ware

***Two year limited warranty**

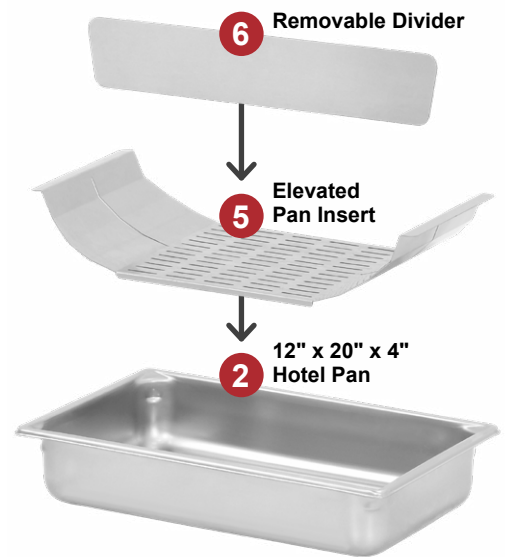

Infrared Elements

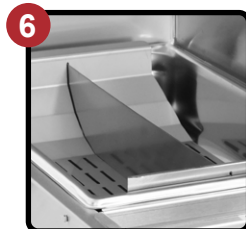

Removable Pan Divider



Bagged Product Storage Bin



Elevated Storage Shelf

((RADIANT HEAT))

SPECIFICATIONS

HEATED FRY DUMP STATION

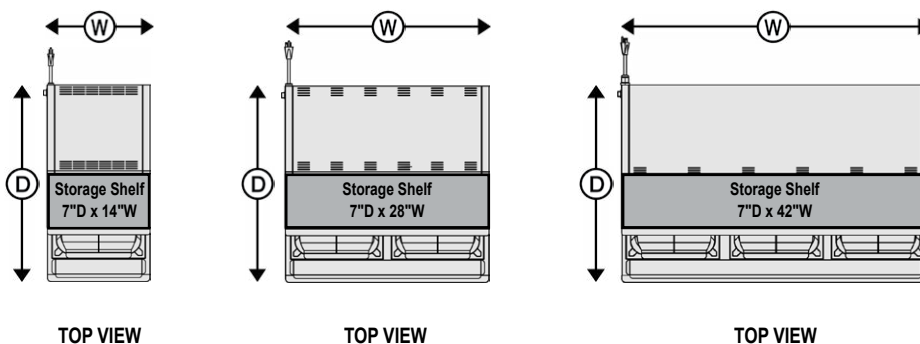
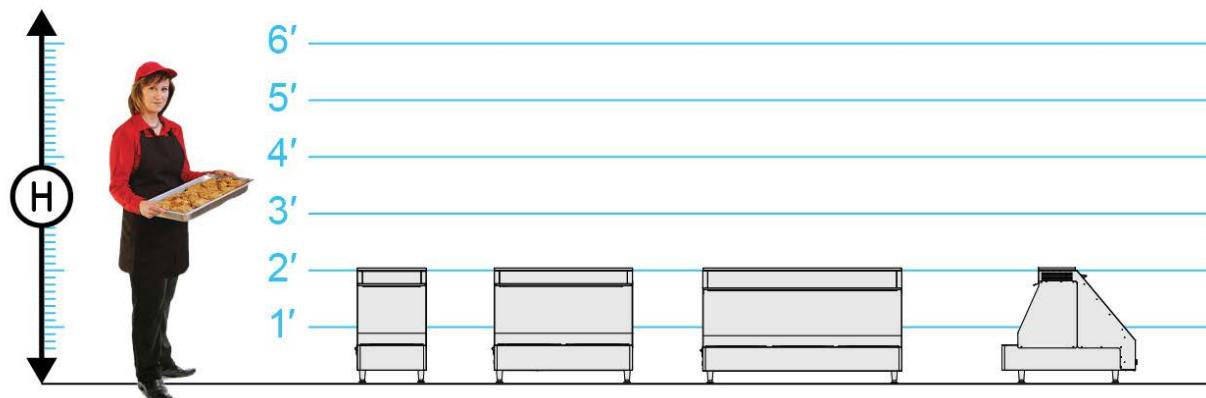

MODEL NUMBER	CAPACITIES OF 4" DEEP PANS 12"x 20" or GN 1/1	OVERALL EXTERIOR DIMENSIONS IN. (mm) (Height Includes Legs)			CLASS 100	
		HIGH "H"	DEEP "D"	WIDE "W"	CASTERS & LEGS [D]	SHIP WT. LBS. (KG)
	1	24.25" (616)	27" (686)	14" (356)	2.5" Legs Adjustable	125 (57)
	2	24.25" (616)	27" (686)	28" (712)	2.5" Legs Adjustable	135 (62)
	3	24.25" (616)	27" (686)	42" (1067)	2.5" Legs Adjustable	155 (71)

MODEL NUMBER	ELECTRICAL DATA	
	HMC-1220-1-FD	HMC-1220-2-FD HMC-1220-3-FD
VOLTS	120	120
WATTS	960	1920
AMPS	8.0	16.0
HERTZ	60	60
PHASE	Single	Single
PLUG USA	5-15P	5-20P*
PLUG CANADA	5-15P	5-30P

*Dedicated Circuit.

CONSTRUCTION. Heliarc welded, single unit construction of stainless steel; 20 gauge polished exterior, 22 gauge stainless steel interior.

INSULATION. Insulated throughout; top, back, and bottom using high density ceramic and fiberglass insulation.

LEGS. Unit includes four (4) 2.5" adjustable legs.

HEAT SYSTEM/CONTROLS. Long life, curved face, ceramic long wave infrared elements heating element, with (2.5 - 6µm) wavelength radiation and bright annealed stainless steel metal reflector to direct deep penetrating focused heat. Side mounted master ON/OFF power switch.

ELECTRICAL CHARACTERISTICS. 3 wire grounded power cord and plug, rear mounted for safety. See electrical data chart above for amperage and receptacle configuration. See electrical data chart for models that may require a dedicated circuit.

INSTALLATION. Unit should not be installed in an area where adverse environmental conditions are present.

