



**FEATURES**

- Oil lubricated rotary vane vacuum pump, nominal speed 282 cf/h (8 m<sup>3</sup>/h);
- Vacuum level control through high precision absolute sensor;
- Maximum vacuum 99.8% (2 millibars);
- 10,2" sealing bar in fireproof technopolymer, easily removable for cleaning;
- Waterproof digital control panel with four capacitive keys;
- Preset program for vacuum packaging in bags of products intended for storage;
- Preset program for vacuum packaging in bags of products intended for sous vide cooking;
- Program for vacuum packing in containers;
- Four adjustable sealing intensity levels;
- Pump oil dehumidification program;
- Resettable oil change alarm;
- Structural technopolymer vacuum chamber, FDA certified for food contact suitability. Incorporates the sealing device and the control panel, easy to clean shape;
- 8mm thick curved and tempered glass cover, coated with 100 micron safety film, high mechanical strength (36 times more resistant than an equivalent PMMA / Plexiglas lid);
- Machine body in AISI304 stainless steel; pump oil drain of the machine body with cover, which prevents the penetration of impurities or insects inside;
- Front opening of the machine body to facilitate access to maintenance;
- Technopolymer protective covers of electronic boards;
- Thermal welding protection system;
- Suction device for external containers;
- Accessory "Easy" for external vacuum in embossed bags;
- 2 PE filling plates for product adjustment and cycle speed up;
- Compact dimensions and side handles, which allow easy handling of the machine.

**DESCRIPTION**

The iconic Evox line represent the synthesis between innovative and ergonomic design, advanced materials and ease of use.

The vacuum chamber is made of structural technopolymer, incorporating the sealing device and the control panel. It is combined with a curved and tempered glass cover with extreme high mechanical resistance.

The absolute vacuum sensor, the ease of maintenance and the compact dimensions make it a precise, fast, versatile and reliable vacuum packing machine.

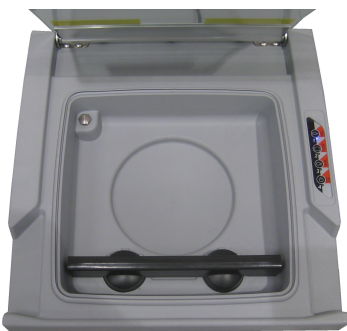

**SEALING BAR 10.2 inch**  
**VACUUM PUMP 282 cf/h**  
**ABSOLUTE SENSOR**  
**CONTROL**

**ACCESSORIES (NOT INCLUDED)**

- Smooth vacuum bags for storage, cooking and "cook & chill";
- Embossed vacuum bags for external vacuum;
- Stainless steel cart with castors and shelf.



Intertek Intertek

According to:  
**UL197 / NSF Hygienic standards**

PROJECT	DATE	APPROVED
ITEM	QTY	

VACUUM PACKAGING MACHINES EVOX25H 8MC/H

UPDATED:  
28/07/2021

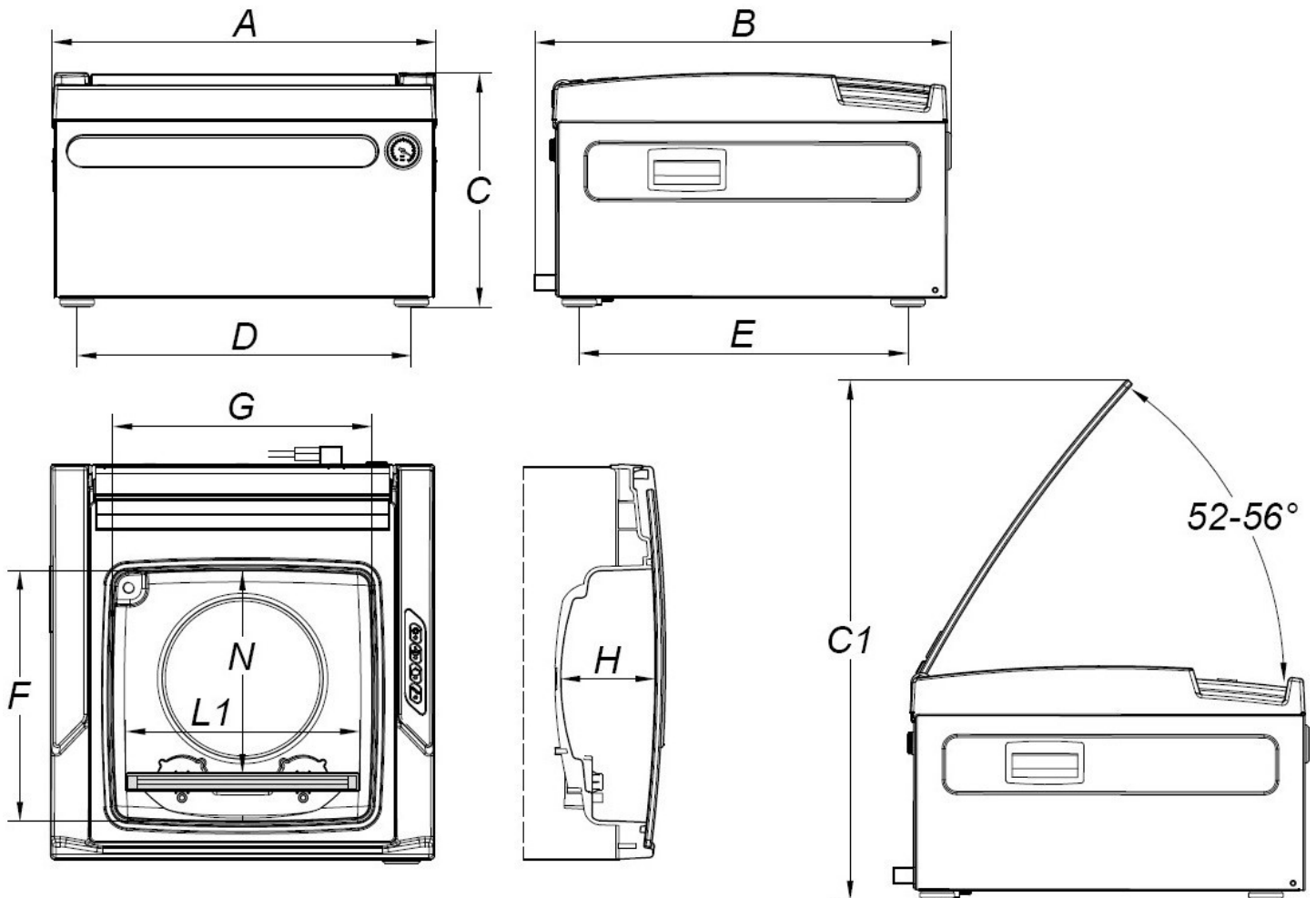

## SPECIFICATIONS

Length of seal L1	inch	10,2
Nominal pump speed	cf/h	282
Final pressure	mbar	2
Chamber size (FxGxH)	inch	11,4x11,8x4,2
Useful chamber space (N)	inch	9,2
Chamber depth (H)	inch	4,2
Chamber volume	Usgal	2,016
Power	W	800
Electrical voltage/Frequency/Phases	V/Hz	110V / 60Hz / 1Ph+N+PE
Power cord and plug		82,6 inch+IEC / Nema 5
Current	A	7,2
Housing materials		Stainless steel (AISI304)
Vacuum chamber material		Technopolymer (Suitable for food contact)
Lid material		Tempered glass covered with safety film
Overall dimensions (AxBxC)	inch	17,4x18,9x10,6
Maximum height with open lid (C1)	inch	23,7
Distance between supports (DxE)	inch	15,2x14,9
Weight (with filling plates)	lbs	59,5
Noise level	dB(A)	58
Environmental operating temperature (min-max)	°F	53,6-104