

Power Pro ***Giraffe***



A heavy duty mobile mixer for large capacity applications

The Power Pro Giraffe, designed for high volume and heavy duty mixing duties, ensures many years of sanitary, uninterrupted food preparation thanks to its stainless steel construction. The heavy duty locking casters and tilting mechanism allow for easy transport, a safe and secure operation and convenient storage.

This heavy duty mixer is ideal for intensive use and for mixing large capacity preparations ranging from 25 to 100 gallons (100 to 400 litres). Choose from a variety of attachment options such as the standard cutter blade which is great for preparations that require mixing like soups and the whip attachment for achieving the perfect blend of light food recipes.

HEAVY DUTY MOBILE MIXER

Power Pro Giraffe

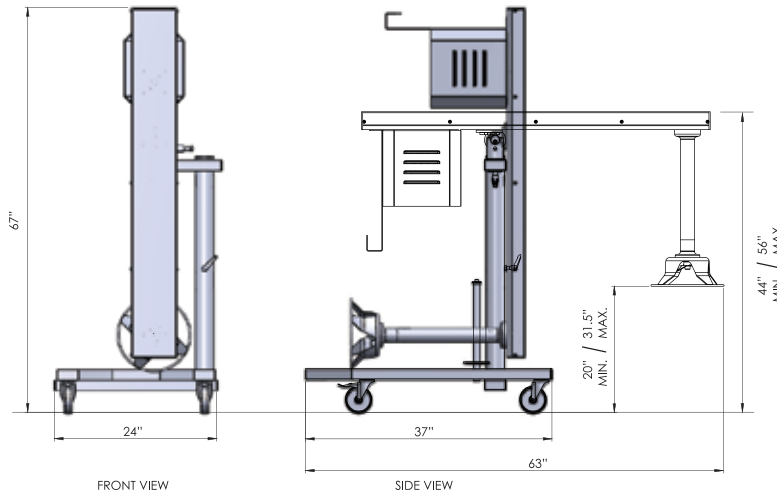

NEW

Transfer your mixed product
in minutes with the new pump!



Thanks to its innovative design, the pump adapts perfectly to the blender attachment for a quick and easy transfer of food preparations.

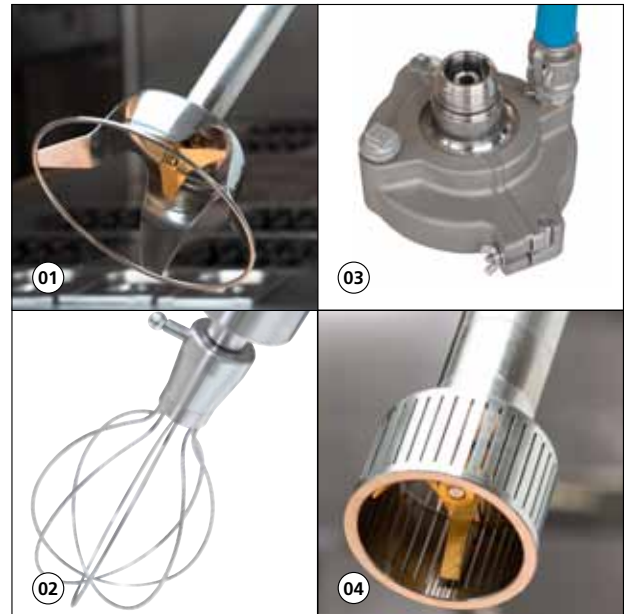

01 - Power Pro Giraffe with standard cutter blade attachment and variable speed	TB002
Electrical specifications:	
Voltage: 230 V, 3 phase, 50/60Hz (other voltage upon request)	
Power output: 1500 W	
Speed : 0 - 4000 R.P.M.	
Thermal magnetic circuit breaker	
Standard cutter blade attachment:	
Diameter: 280 mm / 11"	
Height: 160 mm / 6.5"	
02 - Whip attachment	TB003
The whip attachment is ideal for delicate recipes. It provides the ultimate in mixing flexibility.	
Diameter: 170 mm / 6.5"	
Height: 470 mm / 18.5"	
03 - Pump attachment NEW	TB030
The new pump attachment is ideal for transferring food preparations.	
Diameter: 178 mm / 7"	
Height: 90 mm / 3.5"	
04 - Blender attachment	TB004
The new blender attachment is ideal for emulsifying soups or sauces.	
Diameter: 100 mm / 3.75"	
Height: 90 mm / 3.5"	