

**Pomati**<sup>®</sup>  
CHOCOLATE TECHNOLOGY

**CUBE**



**Use and Maintenance  
Instruction Manual**





*We congratulate you on your great choice, and we thank you and invite you to read this manual to use this tempering machine with no risks and hazards.*

*While reading this manual you will have the opportunity to get the hang of your new machine, and appreciate all the production advantages. You will discover that this machine is very easy to use, and you will learn how you can easily change the process product, optimizing your own production by making it even more yielding; you will learn how applied technology can help you in your business. In fact, the machines manufactured by POMATI Group S.r.l. are the fruits of synthesis of years of experience in the designing and manufacturing of machines for processing chocolate.*

*The dedicated extreme scientific thoroughness and the high degree of professional competence contribute towards enhancing its quality. Studies and close analyses, the use of modern technologies, choices of first-rate materials and components render this product by POMATI Group S.r.l. unique.*

*The quality mark characterizes all our machines, rendering them cost-effective, reliable, easy to use, requiring reduced maintenance, noiseless, safe and ergonomic.*

*In order to maintain POMATI Group S.r.l. machines perfectly in working order, it is imperative that the simple maintenance operations described herein be carried out.*

*Cleaning the machines is essential and necessary to maintain their reliability.*

*The onset of noises indicates the presence of anomalies. The operators who usually work with the machine can recognize their variations and detect their origin.*

*POMATI Group S.r.l. - in order to provide manuals even more thorough and comprehensive - asks for the precious collaboration of the users who can send their remarks or corrections stemming from their direct experience.*

*For the safety of operators, the integrity of machines, devices and systems, it is strictly forbidden to change the use or change any design parameter of the machine, device or system manufactured by POMATI Group S.r.l., to avoid warranty voidance and cancellation. Any changes shall be strictly forbidden and banned.*

*POMATI Group S.r.l. shall not be liable with the immediate cancellation of all warranties in case of change of use, cycle sequences, cycle time, speed, accelerations, in the event of replacement with non-original parts, improper use, tampering, mistreatment, lack of maintenance, removal of safety devices and, in general, of any changes made to the design parameters.*

*A highly-qualified service system is always at your disposal for any technical request and for assisting you while using the machine. Trying to solve the problem on your own, when you do not know the procedure, can pose hazards and may trigger further breakdowns and failures.*

*POMATI Group S.r.l. technical staff wishes you a continued success in using our machines!*

*This instruction manual belongs with the machine, therefore it must always be supplied with it, and in the event that the machine is sold, delivered to the new buyer.*

## TABLE OF CONTENTS

<b>CHAPTER 1 INTRODUCTION</b>	
1.1	TESTING, WARRANTY AND LIABILITY _____ 6/56-1
1.2	ENVIRONMENTAL CONDITIONS _____ 6/56-1
1.3	INTERVENTION REQUEST - TECHNICAL ASSISTANCE _____ 7/56-1
1.4	HOW TO ORDER SPARE PARTS _____ 7/56-1
1.5	MARKING _____ 7/56-1
<b>CHAPTER 2 SAFETY RULES</b>	
2.1	GENERAL SAFETY NOTES _____ 8/56-2
2.2	DEFINITION OF SAFETY TERMS _____ 9/56-2
2.3	CORRECT USE OF THE MACHINE _____ 9/56-2
2.4	TECHNICAL FEATURES OF THE MACHINE _____ 9/56-2
2.5	GENERAL DESCRIPTION AND DESCRIPTION OF MACHINE UNITS _____ 10/56-2
2.6	OPERATOR'S POSITION _____ 12/56-2
2.7	SAFETY DEVICES _____ 13/56-2
2.8	MACHINE ACCESSORIES _____ 13/56-2
2.9	NOISE _____ 14/56-2
2.10	VIBRATIONS _____ 15/56-2
2.11	DEMOLITION AND DISPOSAL _____ 16/56-2
2.12	EC DECLARATION OF MANUFACTURER - ROHS/RAEE _____ 16/56-2
<b>CHAPTER 3 HANDLING, INSTALLATION, ADJUSTMENTS</b>	
3.1	PACKAGE TRANSPORTATION _____ 17/56-3
3.2	LIFTING _____ 17/56-3
3.3	POWER SUPPLY _____ 18/56-3
3.4	INSTALLATION AND COMMISSIONING (counter-top machine) _____ 18/56-3
3.5	INSTALLATION AND COMMISSIONING (in-counter machine) _____ 19/56-3
<b>CHAPTER 4 USE OF CONTROLS</b>	
4.1	OPERATION CONTROLS _____ 20/56-4
4.2	PROCESSING PHASES _____ 22/56-4
4.2.1	<i>Setting of tank heating temperature</i> _____ 22/56-4
4.2.2	<i>Setting of Archimedean screw heating temperature</i> _____ 23/56-4
4.2.3	<i>Processing activity</i> _____ 24/56-4
4.2.4	<i>End of processing stop</i> _____ 24/56-4
4.2.5	<i>Machine discharge</i> _____ 25/56-4
4.3	MENU OF MACHINE PROGRAMS _____ 26/56-4
4.3.1	<i>Set-up of general parameters</i> _____ 27/56-4
4.3.2	<i>Clock</i> _____ 28/56-4
4.3.3	<i>Password</i> _____ 29/56-4
4.3.4	<i>Software info</i> _____ 29/56-4
<b>CHAPTER 5 MAINTENANCE</b>	
5.1	MACHINE CLEANING _____ 30/56-5
5.1.1	<i>Machine cleaning from dark chocolate to milk chocolate to dark chocolate</i> _____ 30/56-5
5.1.2	<i>Machine cleaning for passage from dark chocolate / milk to white chocolate / season end (counter-top machine)</i> _____ 30/56-5
5.1.3	<i>Machine cleaning for passage from dark chocolate / milk to white chocolate / season end (in-counter machine)</i> _____ 33/56-5
5.2	MAINTENANCE _____ 35/56-5
5.2.1	<i>In-counter machine maintenance</i> _____ 35/56-5
5.2.2	<i>Replacement of fuses</i> _____ 35/56-5
5.2.3	<i>Belt tensioning</i> _____ 36/56-5
<b>CHAPTER 6 DIAGNOSTICS</b>	
6.1	GENERAL WARNINGS _____ 37/56-6
6.1.1	<i>Alarm warning messages</i> _____ 37/56-6
6.1.2	<i>Flowcharts</i> _____ 39/56-6
<b>CHAPTER 7 SPARE PARTS AND WIRING DIAGRAM</b>	
7.1	SPARE PARTS _____ 44/56-7
7.2	WIRING DIAGRAM _____ 48/56-7



<b>Pomati Group S.r.l.</b>	<b>Tel. (+39) 0377 33092</b>
Via A. Moro 14/16, industrial zone Mirandola	<b>Fax. (+39) 0377 34446</b>
www.pomati.it	pomati@pomati.it

## DECLARATION OF CONFORMITY

(All. IIA DIR. 2006/42/CE)

### THE MANUFACTURER

Pomati Group S.r.l.		
<i>Company</i>		
Via A. Moro 14/16, industrial zone Mirandola	26845	LO
<i>Address</i>	<i>Zip code</i>	<i>Province</i>
Codogno	Italia	
<i>City</i>	<i>Country</i>	

### DECLARES THAT THE MACHINERY

Melt machine for chocolate	CUBE	
<i>Description</i>	<i>Model</i>	
000	2012	01 16/04/2012
<i>Serial number</i>	<i>Year of constr.</i>	<i>Revision</i>
CUBE		
<i>Trade name</i>		
Counter-top machine, designed and manufactured to melt any type of chocolate		
<i>Intended use</i>		

### COMPLIES WITH THE REQUIREMENTS

Directive 2006/42/CE of the European Parliament and the Council of 17 May 2006 on machinery, and amending directive 95/16/CE.

DIRECTIVE 2004/108/EC OF THE EUROPEAN PARLIAMENT AND OF THE COUNCIL of 15 December 2004 on the approximation of the laws of the Member States relating to electromagnetic compatibility.

DIRECTIVE 2006/95/EC OF THE EUROPEAN PARLIAMENT AND OF THE COUNCIL of 12 December 2006 on the harmonization of the laws of Member States relating to electrical equipment designed for use within certain voltage limits.

#### Reference to technical standards harmonized:

CEI EN 60335-1; CEI EN 60439-2/EC; CEI EN 60439-1; CEI EN 60439-3/A2; CEI EN 60439-2; CEI EN 60204-1; CEI EN 60439-3; UNI 10893; UNI EN ISO 15614-1; UNI EN ISO 14159; UNI EN 811; UNI EN 953; UNI EN 842; UNI EN ISO 13850; UNI EN ISO 13857; UNI EN ISO 13849-1; UNI EN 1037; UNI EN 981; UNI EN 1088; UNI EN 349; UNI EN 894-2; UNI EN ISO 894-1; UNI EN 12852; UNI EN 1672-2; UNI EN 1746; UNI EN ISO 13732-1; UNI EN ISO 13732-3; UNI EN ISO 14122-2; UNI EN ISO 12100;

### AND HE AUTHORIZES

Gianni Lorenzani		
<i>Name</i>		
c/o G.L. Comunicazione s.r.l. - Via XXIV Maggio, 42	43036	PR
<i>Address</i>	<i>Zip code</i>	<i>Province</i>
Fidenza	Italia	
<i>City</i>	<i>Country</i>	

### TO PREPARE THE TECHNICAL FILE FOR IT

**Place and date of issue**  
08/05/2012

**The manufacturer**

**D.C.:** CUBE/000

**Project:** CUBE

project:	Machine:		
CUBE	Tempering machine for chocolate	Year:	2011
G.L. Comunicazione s.r.l.	Mod.: CUBE	Serial number:	000
		Rev.:	00 24/01/2010

## 1.1 Testing, warranty and liability

### Testing

The whole machine is sent to the customer and prepared to be installed after having passed all the tests and inspections laid down by the manufacturer in compliance with the regulations in force.

### Warranty

During the twenty-four months of warranty, **Pomati Group S.r.l.** undertakes to provide those parts they manufacture which proved to be faulty due to materials or processing free of charge.

Such parts shall be returned to **Pomati Group S.r.l. carriage free.**

Warranty covers the supply of any faulty parts.

All the expenses of travelling, board and lodging, transport and labor regarding any replacement of the parts by Pomati Group S.r.l. engineers, which shall be entirely charged to the Buyer.

All those parts subject to wear shall not be covered by warranty.

As regards trade parts, the warranty set forth by the supplier shall be applied.

No compensation for expenses, damages or non-gain borne by the customer shall be acknowledged.

The installation of trade parts not complying with Pomati Group S.r.l. specifications - if trade - or not supplied by Pomati Group S.r.l. - if manufactured by them - cancels and voids the warranty as well as the machine misuse.

### Liability

**Pomati Group S.r.l.** shall not be liable for anomalies in the machine operation or general breakdowns caused by the unauthorized use of the machine or by interventions and/or changes made by external people not authorized by **Pomati Group S.r.l.**

## 1.2 Environmental conditions

The machine working environmental conditions must follow the indications reported below:

Temperature	15°C ÷ +30°C (59°F ÷ 86°F)
Humidity	10% ÷ 90% (not condensed)



**THE MACHINE MUST BE PLACED IN A PLACE SHELTERED FROM RAIN.**

Environmental conditions differing from the ones specified herein may cause serious damages to the machine, in particular to the electrical equipment.



**POSITIONING THE MACHINE IN PLACES DIFFERENT FROM THE ONES DESCRIBED HEREIN CANCELS AND VOIDS THE WARRANTY.**

The storage of machine when not working allow temperature to range between +10°C (50°F) and +60°C (140°F), it being understood all the other precautions.



**IT IS STRICTLY FORBIDDEN TO USE THE MACHINE IN PRESENCE OF EXPLOSIVE ATMOSPHERE OR FIRE HAZARD.**



## 1.3 Intervention request - technical assistance

Every intervention request to the Customer Service must be submitted via fax or email to one of the following addresses:

**Pomati Group S.r.l.**  
Customer Service  
Telefax +39.0377.330.92  
Email: pomati@pomati.it

specifying:

1. type of machine, serial number and year of installation;
2. defects noticed;
3. retailer where the machine was purchased;
4. fiscal document bearing witness to the date of purchase by the user.

## 1.4 How to order spare parts

Every request regarding spare parts must be submitted via fax or email to one of the following addresses:

**Pomati Group S.r.l.**  
Customer Service  
Telefax +39.0377.330.92  
Email: pomati@pomati.it

specifying:

1. Machine model;
2. Serial number;
3. Code of the spare part to be ordered;
4. Required quantity;
5. Means of consignment.

## 1.5 Marking

All identification data of the machine are engraved on its rating plate. Such data shall have to appear always on every document exchanged between the user and the manufacturer, e.g. during every assistance request or when requesting spare parts, etc...

The ID plate is placed on the machines



**IT IS STRICTLY FORBIDDEN  
TO REMOVE OR TAMPER  
WITH THE IDENTIFICATION  
PLATE.**

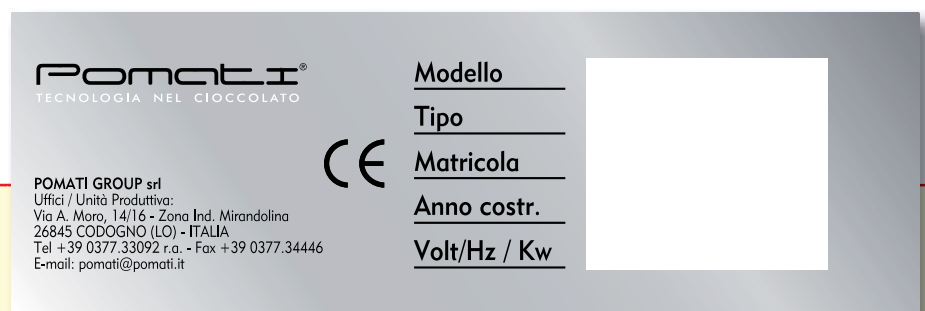

## 2.1 General safety notes



**THE RULES LISTED BELOW MUST BE CAREFULLY READ TO BECOME AN ESSENTIAL PART OF THE DAILY PRACTICE OF USING AND MAINTAINING THE MACHINERY, SO THAT ANY ACCIDENT TO PEOPLE AND/OR DAMAGES TO THINGS SHALL BE AVOIDED.**

1. Do not try to start the machine until its functioning has been clearly understood.
2. Should any doubts arise, even after having carefully and thoroughly read this manual, turn to **Pomati Group S.r.l.** customer Service.
3. Make sure that the whole staff using the machine is informed of all the instructions regarding safety.
4. Before starting the machine, the operator shall check the presence of any visible defects on the safety devices and machine. In this case, immediately notify every apparent breakdown to Pomati Group S.r.l. or to the nearest Customer Service Center.
5. Daily check the correct operation of all the switches and safety devices.
6. Safety devices shall never be removed or made ineffective.
7. During the operations of maintenance, adjustment or repair it might be necessary to bypass some safety devices from the service. This operation must be carried out by authorized personnel only.
8. It is imperative that all the plates and signs placed on the machine be promptly replaced, should they be damaged.
9. The operator must know the function and position of the STOP and START buttons.
10. Replace the broken parts with original spare parts, guaranteed by the manufacturer.
11. Never try anything too risky!
12. All works on live parts shall be carried out by authorized personnel only, who shall work only with the machine unplugged.
13. Do not make any junctions in the electrical connections of electrical circuits.
14. Do not wear clothing, jewelry, accessories that may get caught in moving parts.
15. Keep the area surrounding the machine constantly free of any obstructions.
16. Always wear light gloves and caps and hair nets.
17. Pay the utmost attention to all the caution, warning and danger signs placed on the machine.
18. Enforce safety rules and make workers abide by them. Should any doubts arise, read this manual again before starting to work.
19. The machine shall be used solely for the purposes associated with its design and according to what was contractually laid down by **Pomati Group S.r.l.**



**DO NOT USE THE MACHINE FOR USES DIFFERENT FROM THE ONES DESCRIBED IN THIS MANUAL.  
DO NOT PROCESS PRODUCTS DIFFERENT FROM THE ONES DESCRIBED IN THIS MANUAL.  
DO NOT INCREASE THE MACHINE SPEED BEYOND THE VALUE INDICATED IN THIS MANUAL.**

The misuse of the machine may pose a hazard for the personnel working with it and damage the machine.

For any problem which might arise during the machine's service life and which was not included in this technical manual, please contact our Customer Service to solve the problem as soon as possible.



## 2.2 Defintion of safety terms

The following terms shall be used throughout this manual referring to safety:

<b>Dangerous zone</b>	every zone inside and/or in the proximity of the machine where the presence of a person poses a risk for the safety and health of the personnel.
<b>Exposed person</b>	whoever finds themselves in a dangerous zone both completely and partially.
<b>Operator</b>	person in charge of installing, operate, adjust, service, clean, repair, transport parts of the machine and all the other activities required for its running.
<b>Safety components</b>	component specifically designed by the manufacturer and put on the market separately from the machine to perform safety functions. Safety component is that mechanism whose failure impairs the safety of exposed people.

## 2.3 Correct use of the machine

Counter-top machine for confectionery, pastry making, ice-cream parlor and HORECA laboratories, designed and manufactured to melt every type of chocolate.



**THE MACHINE CANNOT BE USED FOR OTHER TYPES OF PRODUCTS WITHOUT POMATI GROUP S.R.L.'S AUTHORIZATION, WHICH SHALL NOT BE HELD RESPONSIBLE FOR THE DIRECT OR INDIRECT DAMAGES DERIVING FROM THE MACHINE MISUSE.**

## 2.4 Technical features of the machine

1. Tank capacity: Kg 5
2. Heated chocolate tank with thermostat
3. Double heating circuit tank and Archimedean screw
4. Programmable switching on and off
5. Removable Archimedean screw for cleaning and changing chocolate
6. Archimedean screw backflow to discharge chocolate
7. High precision temperature control thermostats
8. Volt 100/240 – Hz 50/60 – KW 0,40 Single phase
9. Dimensions: mm 290 x 413 x h 348

## 2.5 General description and description of machine units

---

CUBE machine for chocolate was conceived for an easy and friendly use by the user, extremely functional for every kind of processing, suitable for filling cups and cones with chocolate, for variegated ice cream, chocolate Moroccan coffee, hot chocolate, shots of chocolate and gianduja (chocolate with soft hazelnut filling).

CUBE series consists of a series of units which interact so that their functionality is always effective. The identifiable units are the following:

- 
1. ***Processing pipe***
  2. ***Foot pedal for dosing control***
  3. ***Switch***
  4. ***Discharge pipe cap***
  5. ***Power cord***
  6. ***Fuses***
  7. ***Worktop (for using in-counter machine)***
  - 7a. ***Worktop (for using counter-top machine)***
  8. ***Inverter***
  9. ***Cooling fan***
  10. ***Product tank***
  11. ***Tank/Archimedean screw connection pipe***
  12. ***Stirrer***
  13. ***Controls panel***
  14. ***Safety microswitch***
  15. ***Motor***
  16. ***Heat exchanger***
  17. ***Archimedean screw resistance***
  18. ***Tank resistance***
  19. ***Socket for foot pedal enabling***
-

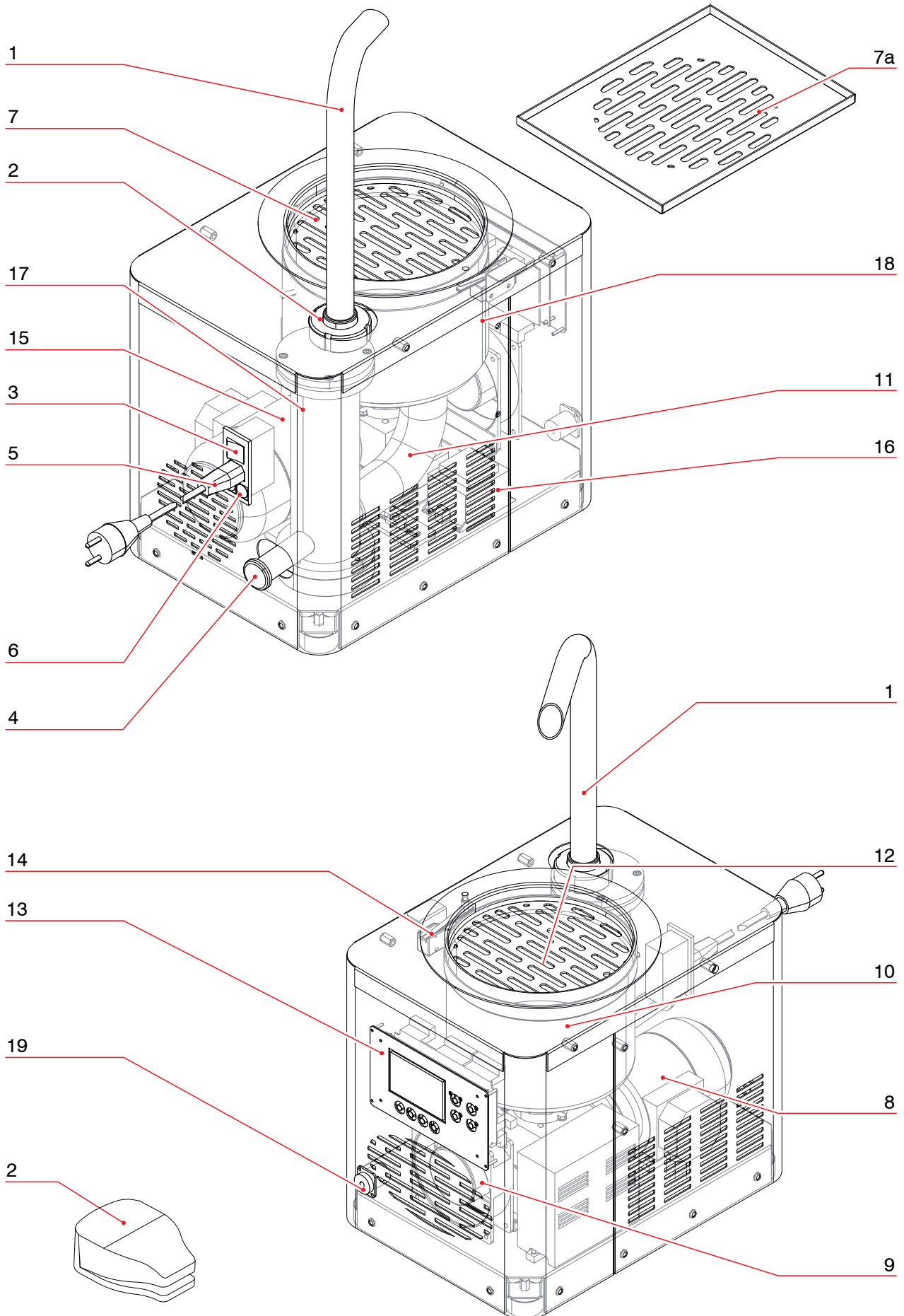

## 2.6 Operator's position

CUBE series can be installed inside a cabinet (correctly arranged in advance) or upon a countertop.

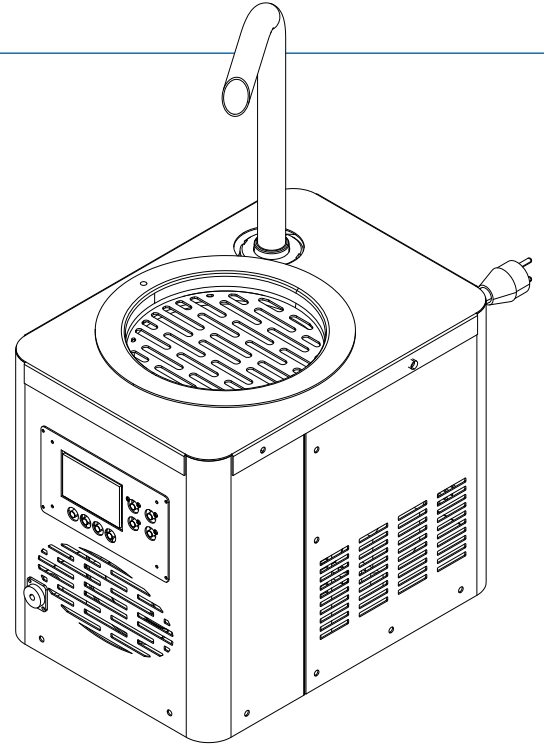

CUBE series requires a single operator who shall stand in front of the machine.



The operator can control chocolate flow by means of the foot pedal connected to the machine.



## 2.7 Safety devices

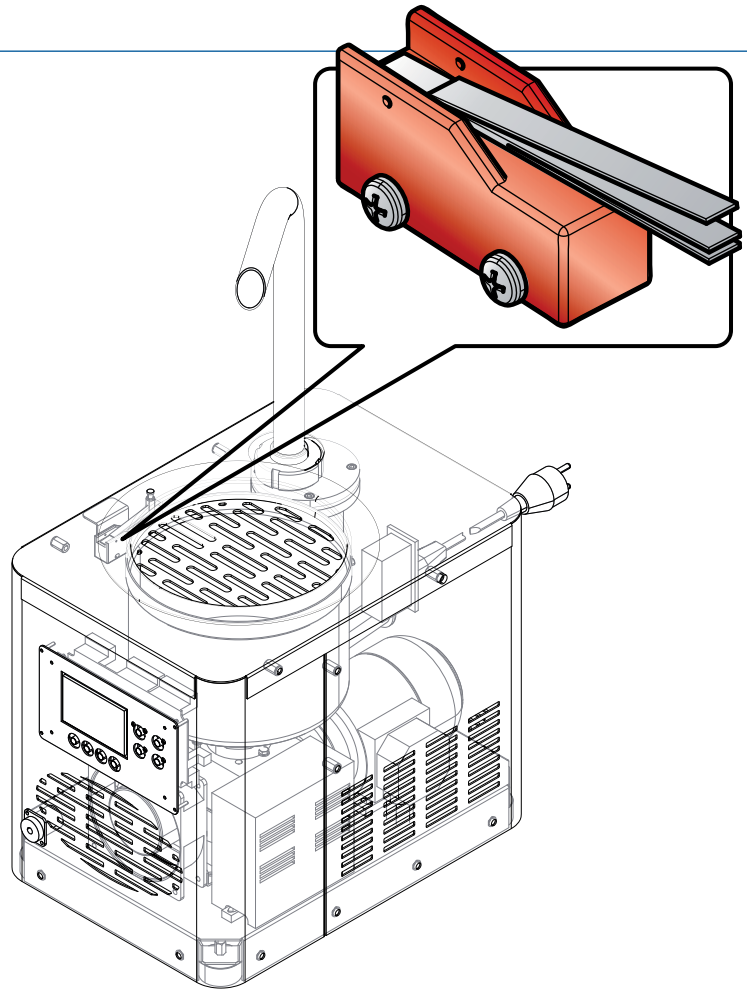

The machines of CUBE series feature a safety device for protecting the stirrer.  
When worktop is taken off, the micron switch is enabled, stopping stirrer motor both in case of an in-counter and counter-top machine.

## 2.8 Machine accessories

CUBE melt machine for chocolate comes with the following accessories:

1. Translated use and maintenance manual
2. Power cord
3. Tank cover
4. Foot pedal for dosing control

## 2.9 Noise

The machine is designed and engineered to minimise noise level at the source.

The measurements done at operator's location on a similar machine gave the following values:

**THE TEST DOCUMENTS AND THE CERTIFICATES OF THE TOOLS ARE HELD BY THE COMPANY POMATI GROUP S.R.L. AND THEY ARE KEPT AT THE DISPOSAL OF THE RELEVANT CONTROL AUTHORITIES.**

The measurement of the level of acoustic pressure equivalent weighted **A** results in conformity with the standard EN ISO 3744. As foreseen by this standard, the machine is positioned with its centre in correspondence to the centre of the reference fictitious parallelepiped, the longitudinal axis directed like the x axis and the back part turned towards nteriore point 1 (see following figure).

Observation:

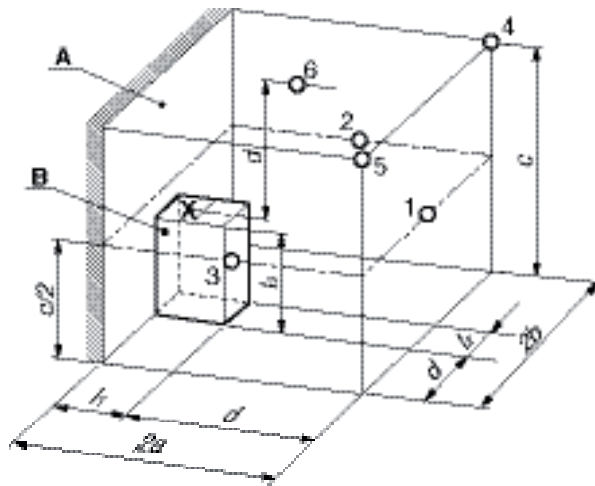

Once the machine has been positioned, the time for the machine to warm up is awaited, until it reaches the normal working temperature.

The instrumentation used for measuring is the following:

- Integrating noise meter Brüel & Kjær mod. 2221 class 1 instrument in conformity with the standards IEC 651 and IEC 804
- Noise level gauger 4230 class 1 in conformity with the standard IEC 942

If the machine is placed in a reverberating environment or where there are other sources of noise and the daily exposure is higher than 85 dB(A), these imply conditions of risk; therefore, in this case the employer is obliged to provide individual protection devices for the workers (earmuffs, plugs).



## 2.10 Vibrations

### Determination of the vibration level generated by the equipment- $A_{(w)sum}$

The magnitude of the vibrating stresses generated by the equipment shall have to be characterized, for every exposure condition, in terms of "Equivalent Frequency-Weighted Acceleration"  $A_{(w)}$   $m/s^2$ . The equivalent acceleration, which is preferably expressed (\*) in S.I. units of measurement (meters per second squared -  $m/s^2$ ), shall have to be quantified for every handle along three standardized directions **X**, **Y** and **Z**, by applying the weighted frequency provided for by the standard ( $W_H$ ), which states the maximum hand-arm system sensitivity to vibratory stimuli with a frequency ranging between 5.6 and 1400 Hz.

Such an interval turns out to be delimited by the octave-band nominal frequencies 8 and 1000 Hz (included), or by the one-third octave bands with nominal frequency ranging between 6.3 Hz and 1250 Hz (included).

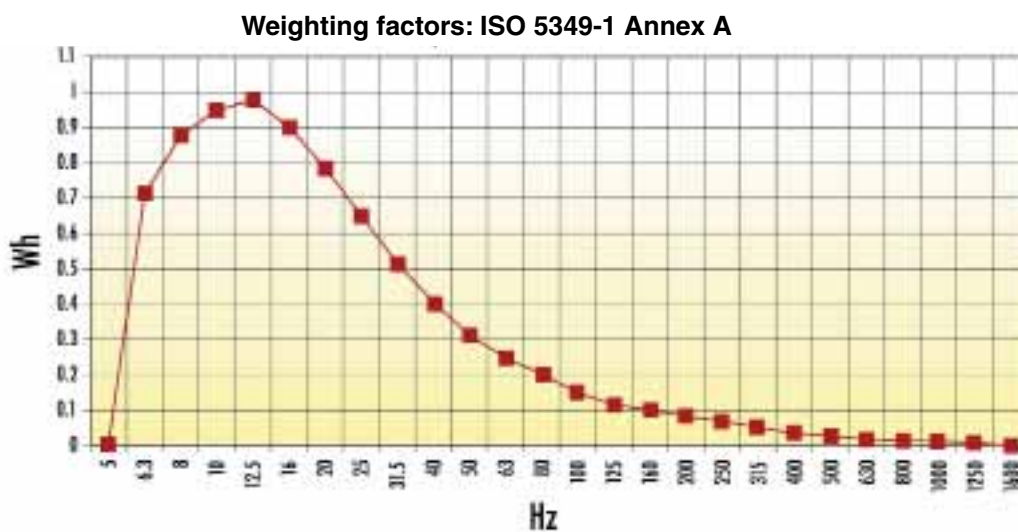

(\*) The logarithmic decibel scale (dB ref.  $10^{-6} m/s^2$ ) is also frequently used

The three axial results shall have to be summed sectorally in order to obtain the total weighted acceleration:

$$A_{(w)sum} = \sqrt{a_{wx}^2 + a_{wy}^2 + a_{wz}^2}$$

The three standardized directions refer to a biodynamic system of coordinates, having their origin connected with the summit of the third metacarpal bone and the **Z** axis, determined by the longitudinal axis of this bone, the **X** axis crosses the palm of the hand while the **Y** axis is orthogonal to the two previous ones.

On the basis of the measurements, carried out through an operative simulation at the test room of the company **Pomati Group S.r.l.** by conforming to the UNI EN ISO 5349-1:2004.

**THE TEST DOCUMENTS AND THE CERTIFICATES OF THE TOOLS ARE HELD BY THE COMPANY POMATI GROUP S.R.L. AND THEY ARE KEPT AT THE DISPOSAL OF THE RELEVANT CONTROL AUTHORITIES.**

## 2.11 Demolition and disposal

The manufacturer expects an estimated service life of 45,000 hours of operation under normal conditions of use. At the end of the actual service life cycle, the company using the product shall dispose of the machine in compliance with the regulations in force, first of all emptying the lubricating fluids and cleaning the various parts, then separating the parts which form the machine.

It is necessary to differentiate the various materials pursuant to what is laid down by the regulations in force in the Country where the machine must be disposed of. The machine does not contain any hazardous components or substances requiring special procedures for their disposal.



**DISPOSE OF THE PRODUCT ABIDING BY THE REGULATIONS IN FORCE IN EACH COUNTRY. STORE THE POLLUTING MATERIALS SUCH AS OILS AND SOLVENTS INSIDE METAL DRUMS ONLY.**

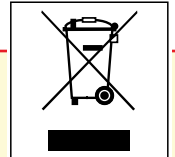

## 2.12 EC Declaration of manufacturer - ROHS/RAEE

**DIRECTIVE 2011/65/EU** (Directive RoHS) of the European Parliament and of the council of 08 June 2011 on the restriction of the use of certain hazardous substances in electrical and electronic equipment.

**DIRECTIVE 2002/96/CE** (Directive WEEE) of the European Parliament and of the council of 27 January, on waste electrical and electronic equipment. With reference to the above Directives and in particular to ENCLOSURES "I A" and "I B" of Directive 2002/96/CE, Pomati Group S.r.l., declares that its products.

DO NOT FALL WITHIN THE FIELD OF APPLICATION OF THE 2011/65/EU DIRECTIVE

Restricted substances referred to in Article 4(1) and maximum concentration values tolerated by weight in homogeneous materials:

Lead	(0,1 %)	Mercury	(0,1 %)
Cadmium	(0,01 %)	Hexavalent chromium	(0,1 %)
Polybrominated biphenyls (PBB)	(0,1 %)	Polybrominated diphenyl ethers (PBDE)	(0,1 %)

Raw materials used by Pomati Group S.r.l., in its components, fall within the EXEMPTIONS limits.

All surface treatments and plastic materials in Pomati Group S.r.l., products do not contain the prohibited substance listed in the 2002/95/CE directive.

### EC DECLARATION OF MANUFACTURER - **REACH**

**DIRECTIVE 2006/121/EC** (REACH Directive) of the European Parliament and Council of 18 December 2006 concerning the Registration, Evaluation, Authorisation and Restriction of Chemicals.

With reference to the above-mentioned Directives, **Pomati Group S.r.l.** declares that the products they market have been pre-registered by our suppliers on December 1st, 2008.

Pomati Group S.r.l. products do not originally contain any SVHCs (Substances of Very High Concern) in total percentage exceeding 0,1%.



## 3.1 Package transportation

Handle by means of transpallets by fitting the forks into the suitable seats of pallet. Use transpallets with an adequate capacity (<150 Kg). Upon delivering the machine, it is necessary to check that damages which could impair the correct machine operation - besides visible damages - were not caused.

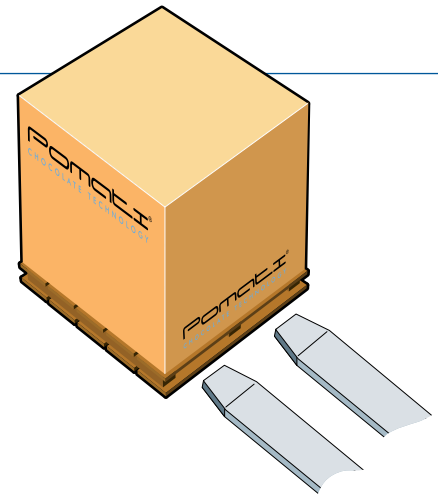

## 3.2 Lifting

Once the package has been brought near the place where the machine will be installed, it is necessary to cut the straps (A) and extract the carton (B) by pushing it upward.

Cut the strap fastening the machine to the pallet (C), collect the documents and attachments placed on the machine (D).



**PAY SPECIAL ATTENTION DURING THE REMOVAL OF STRAPS: THEY MIGHT ACCIDENTALLY HIT THE OPERATOR WHILE CUTTING.**



**ONLY ONE PERSON IS REQUIRED TO TRANSPORT AND ASSEMBLE THE MACHINE**



In the event that the machine is stored during extended periods of inactivity, it is recommended to store it indoor, sheltered against bad weather, in a chemical-free environment.

Before storing it, it is recommended to unplug it and thoroughly clean the machine. The machine must be stored in environments at appropriate temperature (from +10° C to + 60° C) / (from 50° F to 140°F).

### 3.3 Power supply

CUBE machine for chocolate must be powered with a voltage corresponding to the value indicated in the CE rating plate. Plug the the machine only into a line with efficient earthing cable. In case of doubts, do not plug the machine.



**USING TOO LONG EXTENSION CORDS OR CURRENT GENERATORS MAY CAUSE THE FOLLOWING PROBLEMS:**

1. **SLOW MOTOR START WITH PROTECTION INTERVENTION;**
2. **MOTOR OVERHEATING WITH DECREASE IN POWER;**
3. **FAILURE OF ON-OFF SWITCH**

### 3.4 Installation and commissioning (counter-top machine)

Upon installing the tempering machine, and whenever the machine needs to be restarted after a period of inactivity, a first commissioning is required:



**A 2-hour pre-heating is recommended upon each start to optimize the machine operation**

1. Fit the processing pipe into its suitable seat and screw the fixing ring nut (A).
2. Insert the plug (B) into the connector (C) placed in the rear of the machine and enable the main switch “0-1” (D).
3. Install worktop onto the tank, making sure that the pin (E) is fully inserted into the hole (F).
4. Plug power cord into a proper socket.

**MAKE SURE THE FOOT PEDAL FOR DOSING CONTROL IS CORRECTLY PLUGGED IN. IF IT IS NOT PLUGGED IN OR IF IT HAS BEEN PLUGGED INCORRECTLY, THE MACHINE DOES NOT WORK.**



**POMATI GROUP SHALL NOT BE LIABLE FOR DAMAGES CAUSED TO THE PROCESSED CHOCOLATE AND FOR MISUSING THE MACHINE.**

**SHOULD ANY DOUBTS ARISE, REFER TO THIS MANUAL BEFORE ACTING.**



## 3.4 Installation and commissioning (in-counter machine)

Upon installing the tempering machine, and whenever the machine needs to be restarted after a period of inactivity, a first commissioning is required:

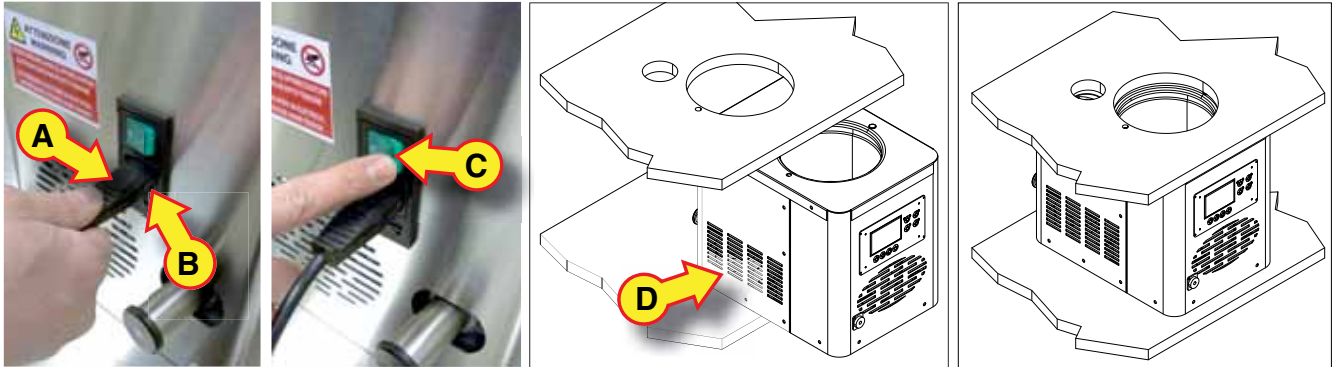

1. Insert plug (A) into the connector (B) placed on the rear of the machine and enable main switch “0-1” (C).
2. Place the machine (D) inside the cabinet, checking the positioning of the holes previously drilled in the cabinet.



**HOLES MUST BE DRILLED IN ADVANCE ON THE COUNTERTOP IN ORDER TO CORRECTLY INSTALL THE MACHINE INSIDE A CABINET, AS SHOWN IN THE PICTURE. THE COMPARTMENT WHERE THE MACHINE IS PLACED SHALL REMAIN OPEN, AND AT LEAST 6 CM OF SPACE SHOULD BE LEFT AROUND IT TO ALLOW AIR TO CIRCULATE FREELY.**

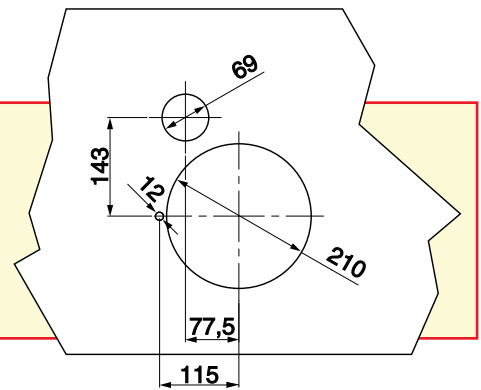

3. Fit processing pipe into its suitable seat (E) and screw it.
4. Install the worktop (F) onto the tank.
5. Make sure that safety pin (G) is fully inserted into the hole previously drilled in the cabinet (H).

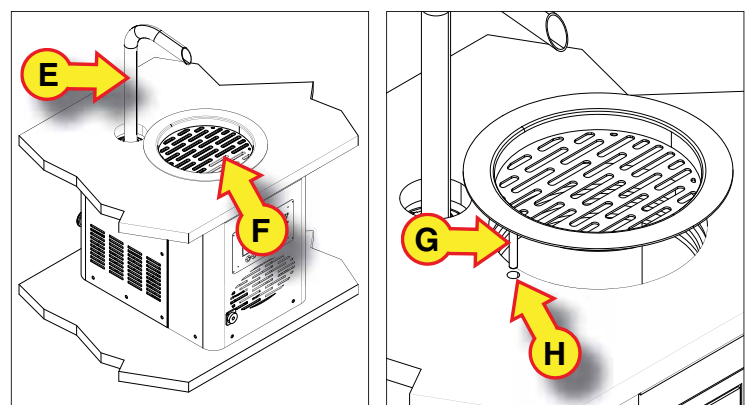

**MAKE SURE THE FOOT PEDAL FOR DOSING CONTROL IS CORRECTLY PLUGGED IN. IF IT IS NOT PLUGGED IN OR IF IT HAS BEEN PLUGGED INCORRECTLY, THE MACHINE DOES NOT WORK.**



**POMATI GROUP SHALL NOT BE LIABLE FOR DAMAGES CAUSED TO THE PROCESSED CHOCOLATE AND FOR MISUSING THE MACHINE. SHOULD ANY DOUBTS ARISE, REFER TO THIS MANUAL BEFORE ACTING.**

## 4.1 Operation controls

The functions of the control panel are described below:



- |                                               |                                                                                                                                                                                                                                                                                                                                                                                  |
|-----------------------------------------------|----------------------------------------------------------------------------------------------------------------------------------------------------------------------------------------------------------------------------------------------------------------------------------------------------------------------------------------------------------------------------------|
| 1. <b>MENU</b>                                | To enter the programming menu and start the process operating cycle by entering or modifying the preset parameters. Functional parameters can be changed only by highly skilled personnel.                                                                                                                                                                                       |
| 2. <b>Down arrow key</b>                      | To scroll programming pages upward or, once inside the recipes, to increase the parameters. These data are displayed on digital display.                                                                                                                                                                                                                                         |
| 3. <b>Up arrow key</b>                        | To scroll programming pages upward or, once inside the recipes, to decrease the parameters. These data are displayed on digital display.                                                                                                                                                                                                                                         |
| 4. <b>ENTER</b>                               | Confirmation key. To enter and display parameters contained inside the programming pages or to confirm data entry.                                                                                                                                                                                                                                                               |
| 5. <b>Stirrer</b>                             | It enables or disables the function of the motor and stirrer inside the tank. Its functioning is not immediate, since it is enabled only when set heating temperature is reached. At the end of the 2-hour pre-heating set in the program, a safety device inhibits its operation if the worktop has not been correctly assembled.                                               |
| 6. <b>Archimedean screw rotation reversal</b> | Key usually enabled at the end of the production. It allows discharging chocolate from the processing pipe into the heated tank. This function is also used to change chocolate. It can be used only when the stirrer motor is not working and the machine is in heating function. It is necessary to hold the button down to make the Archimedean screw rotation reversal work. |



### 7. **Digital display**

To display the set data and information to use T5 ICE machine for chocolate, to extend LCD life span. If the push-button panel is not used for 10 minutes, it automatically turns off. It can be reactivated by simply pressing any key.



**THE OPERATOR DIRECTLY INTERVENES IN THE MACHINE CENTRAL UNIT AND/OR PLC BY MEANS OF THE PUSH-BUTTON PANEL. FOR THIS REASON, EVERY OPERATION MUST BE CARRIED OUT BY PAYING THE UTMOST ATTENTION.**

**IF A COMMAND GIVEN BY THE OPERATOR IS NOT CARRIED OUT BY THE MACHINE, MAKE SURE THAT THE MIXTURE PROCESSING CONDITIONS ALLOW THE SET PROCESSING BEFORE DECLARING A HYPOTHETICAL FAILURE OR MALFUNCTIONING**



**ANY CHANGES MADE WITHIN THE PROCESSING PARAMETERS WILL BE AUTOMATICALLY RECORDED, IF THEY ARE NOT CONFIRMED WITHIN 60 SECONDS BY PRESSING THE ENTER KEY.**

## 4.2 Processing phases

### 4.2.1 Setting of tank heating temperature

Press the enter key to change chocolate melting temperature inside the tank.



The data (A) starts flashing on display.

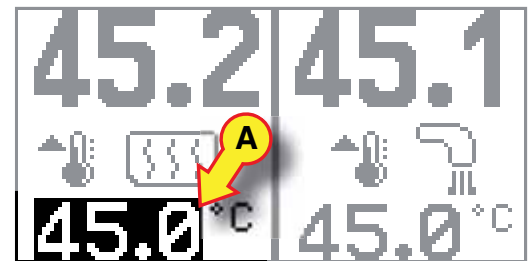

It is possible to change the melting temperature by means of the up and down arrow keys; temperature inside the tank is increased using the up arrow key (B), while it is diminished using the down arrow key (C).

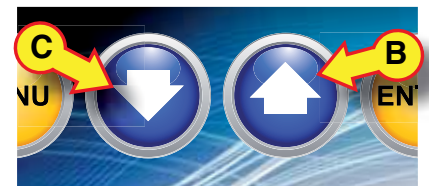

The new set data will be confirmed by pressing the “enter” key twice.





#### 4.2.2 Setting of Archimedean screw heating temperature

Press key twice to change the heating temperature of chocolate Archimedean screw.



The data (A) starts flashing on display.

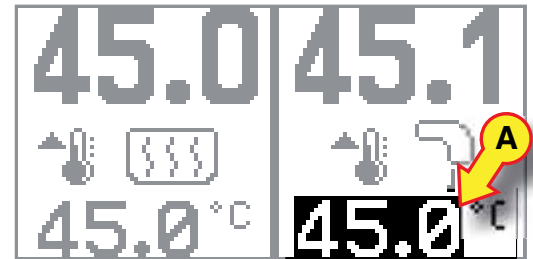

It is possible to change chocolate temperature inside the Archimedean screw by means of the up and down arrow keys; temperature inside the tank is increased using the up arrow key (B), while it is diminished using the down arrow key (C).

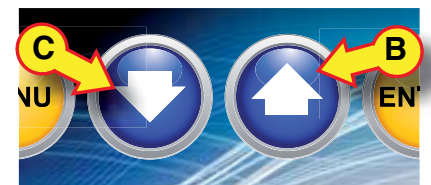

The new set data will be confirmed by pressing the “enter” key.



#### 4.2.4 Processing activity

Once the first commissioning operations have been successfully completed and the correct heating temperature have been set, the chocolate mass can be put inside the machine. If it is solid, wait for it to be completely melted.



**BEFORE STARTING THE STIRRER, IT IS NECESSARY THAT THE MELTED CHOCOLATE MASS HAS REACHED THE CORRECT HEATING TEMPERATURE.**



**IF CHOCOLATE THAT HAS ALREADY REACHED THE PROPER TEMPERATURE IS INSERTED, AND THE MACHINE HAS BEEN JUST STARTED, IT IS POSSIBLE TO BYPASS PRE-HEATING BY CHANGING THE CONFIGURATION THROUGH GENERAL PARAMETERS.**



**START THE STIRRER BY PRESSING THE KEY (A) AND WAIT FOR THE CHOCOLATE TO COME OUT FROM THE PROCESSING PIPE. SHOULD IT NOT HAPPEN, STOP THE STIRRER AND CHECK THE HEATING TEMPERATURE OF THE PROCESSED CHOCOLATE.**



#### 4.2.5 End of processing stop

Once the processing is over, stop the stirrer by pressing the key (A).



**IT IS ADVISABLE TO KEEP MELTED CHOCOLATE AT THE PROPER TEMPERATURE. TO THAT END, DO NOT UNPLUG POWER SUPPLY DURING THE MACHINE STOP PERIOD.**



### 4.2.6 Machine discharge

**BEFORE DISCHARGING THE MACHINE, IT IS NECESSARY TO GET AN ADEQUATE CONTAINER TO COLLECT THE CHOCOLATE LEFT INSIDE.**

Start the stirrer and collect chocolate coming out from the processing pipe inside the container previously placed under it (B).



When the tank is empty, stop the stirrer by pressing button (A); LED turns off.

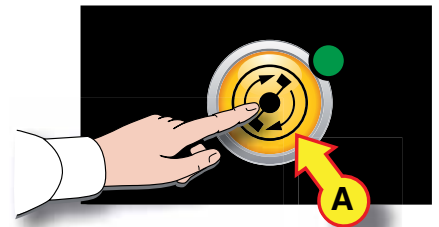

Place a suitable container for collecting the chocolate (C) under the discharge pipe at the bottom of the Archimedean screw on the machine rear; remove the closing cap (D) from the discharge pipe to collect the chocolate (E) left inside the processing pipe and Archimedean screw.

Start Archimedean screw rotation reversal by holding the button (F) down until all chocolate still found in the machine has come out.

Release the button and re-mount the cap of the discharge pipe.

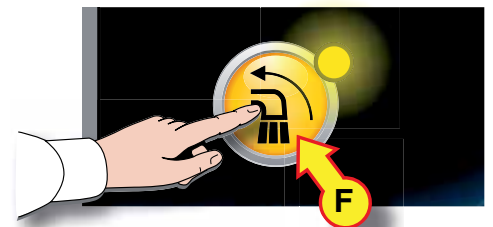

**WHEN WORKING WITH WHITE CHOCOLATE, IT IS NECESSARY TO THOROUGHLY CLEAN SOME PARTS OF THE MACHINE.  
REFER TO THE SHEETS CONTAINED IN THIS CHAPTER TO MAINTAIN AND CLEAN THOSE PARTS.**

## 4.3 Menu of machine programs

A programming menu is found inside the control panel, from which some functional parameters of the machine can be modified and customized. Proceed as follows:

Press button "MENU" to access the index of functional parameters.

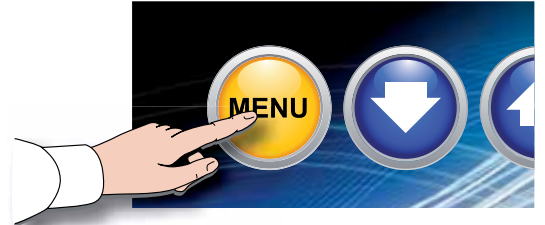

Through buttons "UP ARROW" (A) and "DOWN ARROW" (B) position the cursor on the selected parameter to be modified and

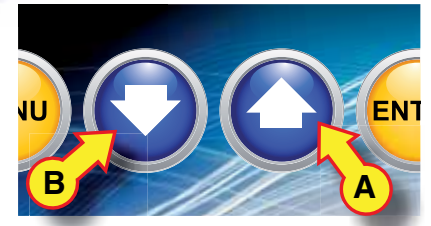

press button "ENTER" to confirm.



Position the cursor on the selected parameter to be modified inside the parameter by means of the arrow keys ; press button "ENTER" to enter.

Change the parameter by means of the arrow keys and press button "ENTER" to confirm.

Press button "MENU" to quit the programming menu.



### 4.3.1 Set-up of general parameters

**LCD contrast:**

To adjust the brightness of the display to the laboratory lighting.

**Reverse LCD:**

To modify display color. When “OFF” the display is blue with white digits, when “ON” the display is white with blue digits.

**Language:**

To select the language according to the country where the machine is used.

**Pre-heating disabling:**

To enable or disable the 2-hour pre-heating program which is active upon every switching on of the machine. In the “OFF” mode pre-heating is enabled; in the “ON” mode pre-heating is disabled.

**Tank heating:**

To enable or disable the tank heating function in automatic mode upon every switching on of the machine. In the “OFF” mode tank heating is disabled; in the “ON” mode tank heating is enabled.

**Archimedean screw heating:**

To enable or disable the Archimedean screw heating function in automatic mode upon every switching on of the machine. In the “OFF” mode Archimedean screw heating is disabled; in the “ON” mode Archimedean screw heating is enabled.

```

MENU
1) CFG GEN STAN
2) CLOCK
3) PASSWORD
4) INFO SOFTW.
  
```

```

CFG GEN STAN:
1) LCD CONTRAST: 0
2) REVERSE LCD: OFF
3) LANGUAGE: ITA
4) DEACT PREHEAT: OFF
5) HEAT TANK: ON
6) HEAT SCREW: ON
  
```

```

CFG GEN STAN:
1) LCD CONTRAST: 0
2) REVERSE LCD: OFF
3) LANGUAGE: ITA
4) DEACT PREHEAT: OFF
5) HEAT TANK: ON
6) HEAT SCREW: ON
  
```

```

CFG GEN STAN:
1) LCD CONTRAST: 0
2) REVERSE LCD: OFF
3) LANGUAGE: ITA
4) DEACT PREHEAT: OFF
5) HEAT TANK: ON
6) HEAT SCREW: ON
  
```

```

CFG GEN STAN:
1) LCD CONTRAST: 0
2) REVERSE LCD: OFF
3) LANGUAGE: ITA
4) DEACT PREHEAT: OFF
5) HEAT TANK: ON
6) HEAT SCREW: ON
  
```

```

CFG GEN STAN:
1) LCD CONTRAST: 0
2) REVERSE LCD: OFF
3) LANGUAGE: ITA
4) DEACT PREHEAT: OFF
5) HEAT TANK: ON
6) HEAT SCREW: ON
  
```

```

CFG GEN STAN:
1) LCD CONTRAST: 0
2) REVERSE LCD: OFF
3) LANGUAGE: ITA
4) DEACT PREHEAT: OFF
5) HEAT TANK: ON
6) HEAT SCREW: ON
  
```

### 4.3.2 Clock

**Time menu:**

it is the submenu of the clock program. DATE/TIME parameter can be accessed from here and date,

day of the week and time can be changed.

**Time menu:**

it is the submenu of the clock program. The WEEKLY PROGRAM can be accessed from here and the heating resistance switching on and off is set.

When "OFF" the program is disabled and resistances work 24/7 (*machine always ON*).

When "ON" the program is enabled and resistance switching on and off is adjusted according to our needs and to optimize energy efficiency. From left to right, the first column shows the days of the week; set the switching off time in the second column; set the switching on time in the third column.

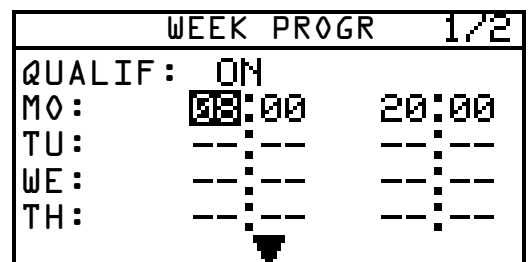
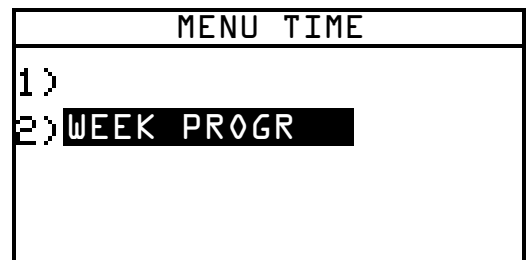
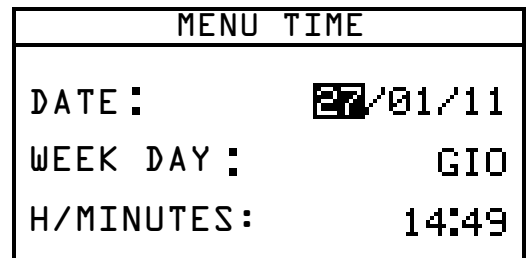
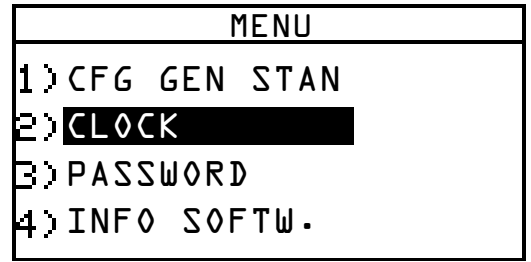

**IT IS ADVISABLE TO SET THE HEATING RESTART AT LEAST 3 HOURS BEFORE THE USE.**



### 4.3.3 Password

```
MENU
1)CFG GEN STAN
2)CLOCK
3)PASSWORD
4)INFO SOFTW.
```

### 4.3.4 Software info

```
MENU
1)CFG GEN STAN
2)CLOCK
3)PASSWORD
4)INFO SOFTW.
```

```
SOFTW VERSION
NAME : TpcT5 V. 2.0
DATE : 18/01/11
Checksum: 0C5D
```

**SW version:**

To display important data on the software version installed on the machine.

## 5.1 Machine cleaning

### 5.1.1 Machine cleaning from dark chocolate to milk chocolate to dark chocolate



**MAKE SURE THE MACHINE IS STILL HOT FOR THIS OPERATION.**



After performing the operations described in paragraph “**Machine discharge for changing chocolate**”, it is necessary to clean the product tank by disassembling the stirrer (A) turning it clockwise. Use a soft cloth to clean the inner part of the tank and thoroughly rinse the stirrer.



**THOROUGHLY WASH WITH HOT WATER ONLY. WATER TEMPERATURE SHALL NOT EXCEED 60°C.**



**DO NOT USE ANY TYPE OF DETERGENTS, SINCE ANY RESIDUES MIGHT CONTAMINATE THE CHOCOLATE DRY THE MACHINE PARTS THOROUGHLY.**

### 5.1.2 Machine cleaning for passage from dark chocolate / milk to white chocolate / season end (counter-top machine)



**MAKE SURE THE MACHINE IS UNPLUGGED, BUT STILL HOT FOR THIS OPERATION.**



Switch the machine off by means of the main switch “0-1”, pull out the plug from connector.



Remove worktop (A).

It is necessary to disassemble the stirrer (B) by rotating it clockwise to clean the tank. Use a soft cloth (C) to clean the inside of tank and thoroughly clean the stirrer.



**DO NOT USE ANY TYPE OF DETERGENTS, SINCE ANY RESIDUES MIGHT CONTAMINATE THE CHOCOLATE DRY THE MACHINE PARTS THOROUGHLY.**



**ONCE THE MACHINE HAS BEEN CLEANED AND DRIED, IT IS ADVISABLE TO LET IT ON FOR 12 HOURS SET TO A 50°C TEMPERATURE WITH THE ARCHIMEDEAN SCREW DISASSEMBLED TO ALLOW ANY RESIDUAL HUMIDITY TO EVAPORATE.**



**DURING CLEANING PHASES IT IS STRICTLY FORBIDDEN TO USE SCREWDRIVERS OR SHARP TOOLS TO AVOID WARRANTY VOIDANCE.**



Unscrew the processing pipe (D). Unscrew the upper casing of machine by means of a wrench (E).

Lift the upper casing (F), paying utmost attention to the electrical connection of safety micron. Unplug it through the connector (G).



Now the upper casing can be taken off and placed on the countertop.

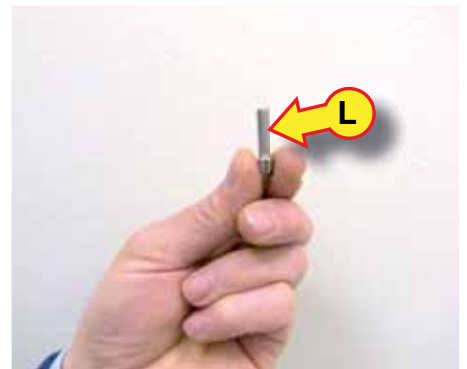

Unscrew the fixing screws (H), lift the ring nut (I). Use one of the fastening screws of ring nut (L), screw it on top of the



**!** THOROUGHLY WASH WITH HOT WATER ONLY. WATER TEMPERATURE SHALL NOT EXCEED 60°C.

Archimedean screw (M), and extract it (N).

Reassemble the machine following the assembly instructions in reverse order.

**!** DURING THE REASSEMBLY PROCEDURE, PAY ATTENTION THAT THE GASKET (O) IS IN GOOD SHAPE AND CORRECTLY POSITIONED IN ITS SEAT WHILE REPOSITIONING THE ARCHIMEDEAN SCREW COVER.





### 5.1.3 Machine cleaning for passage from dark chocolate / milk to white chocolate / season end (in-counter machine)

In order to correctly perform washing operations, proceed as follows:

switch machine off by means of the main switch "0-1", pull out the plug from connector.



**MAKE SURE THE MACHINE IS UNPLUGGED, BUT STILL HOT FOR THIS OPERATION.**

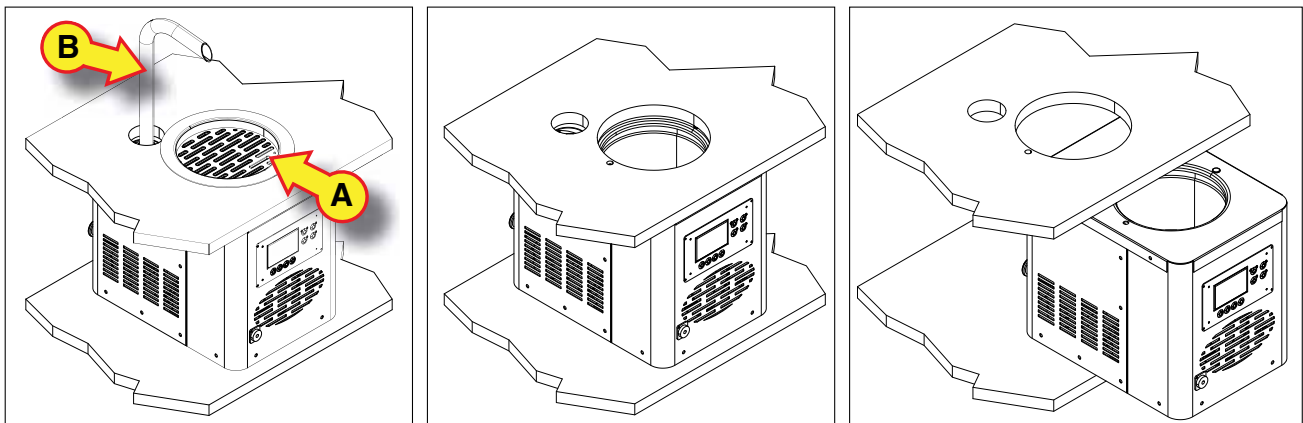

Take off the worktop (A), unscrew the processing pipe (B), extract the machine from inside the cabinet and place it on the countertop.

It is necessary to disassemble the stirrer (C) by rotating it clockwise to clean the tank. Use a soft cloth (D) to clean the inside of tank and thoroughly clean the stirrer.



**DO NOT USE ANY TYPE OF DETERGENTS, SINCE ANY RESIDUES MIGHT CONTAMINATE THE CHOCOLATE DRY THE MACHINE PARTS THOROUGHLY.**



**ONCE THE MACHINE HAS BEEN CLEANED AND DRIED, IT IS ADVISABLE TO LET IT ON FOR 12 HOURS SET TO A 50°C TEMPERATURE WITH THE ARCHIMEDEAN SCREW DISASSEMBLED TO ALLOW ANY RESIDUAL HUMIDITY TO EVAPORATE.**



**DURING CLEANING PHASES IT IS STRICTLY FORBIDDEN TO USE SCREWDRIVERS OR SHARP TOOLS TO AVOID WARRANTY VOIDANCE.**



Unscrew the upper casing of machine (E) paying utmost attention to the electrical connection of safety micron placed under the casing. Lift the latter (F), unplug safety micron connector(G),



unscrew fixing ring nut (H), lift ring nut (I) by means of one of the fastening screws (L), screw it on



**!** THOROUGHLY WASH WITH HOT WATER ONLY. WATER TEMPERATURE SHALL NOT EXCEED 60°C.

the top of the Archimedean screw (M), and extract it (N).

Reassemble the machine following the assembly instructions in reverse order.

**!** DURING THE REASSEMBLY PROCEDURE, PAY ATTENTION THAT THE GASKET (O) IS IN GOOD SHAPE AND CORRECTLY POSITIONED IN ITS SEAT WHILE REPOSITIONING THE ARCHIMEDEAN SCREW COVER.





## 5.2 Maintenance

### 5.2.1 In-counter machine maintenance

In order to perform the correct maintenance, it is necessary to extract the machine from the cabinet and place it on the countertop. Proceed as follows:

Switch the machine off by means of the main switch "0-1", pull out the plug from connector.



**BEFORE PERFORMING THIS OPERATION, ENSURE THE MACHINE IS UNPLUGGED AT THE MAINS, BUT STILL HOT.**

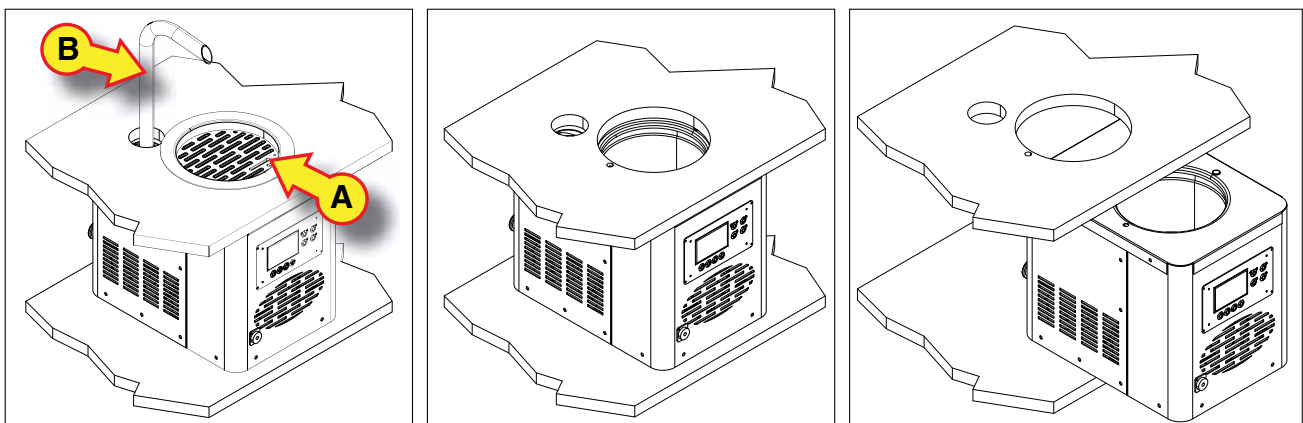

Take off the worktop (A), unscrew the processing pipe (B), extract the machine from inside the cabinet and place it on the countertop.

### 5.2.2 Replacement of fuses



If the machine does not power on, it is necessary to check the fuses placed under the power supply connector; in case they are broken, it is necessary to replace them with one fuse having the same current rating.

Switch the machine off by means of the suitable switch; pull out the plug from connector and unscrew the fuse holder by means of a low-profile average-slotted screwdriver. Replace with one having the same characteristics.

### 5.2.3 Belt tensioning

The driving belt is placed at the bottom of the machine. Its correct tensioning and wear condition must be checked. It is necessary to:

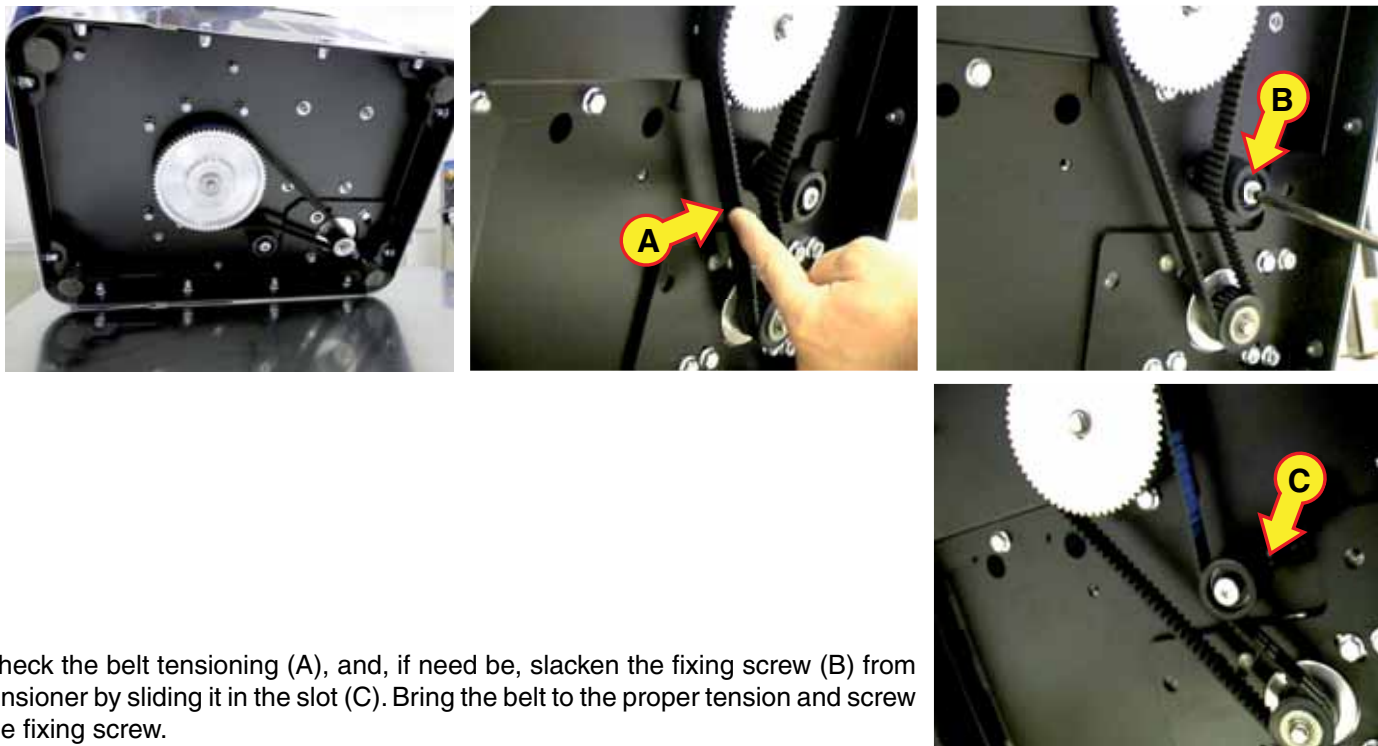

Check the belt tensioning (A), and, if need be, slacken the fixing screw (B) from tensioner by sliding it in the slot (C). Bring the belt to the proper tension and screw the fixing screw.



## 6.1 General warnings

Most anomalies and problems that arise during the machine operation are promptly signalled by the machine automatically:

- warnings and signals are only messages given by the machine to the operator while it is still working;
- alarms cause the machine stop with a warning message of emergency stop that occurred through the operator's panel.  
To restart the machine it is first necessary to remove the cause that triggered the emergency.

**General operator:** searches for operation anomalies, and, if he can do that, he also removes the causes of the anomaly to reset the proper operation of the machine.

**The maintenance electrician/mechanic:** intervenes later, in the event that the operator could not identify the cause of the problem or that restoring the correct operation of the machine entails the execution of very complex operations.

You will find below type of alarms which might be displayed:

- a) tables of warnings and alarms:** complete list of all warnings and alarms with possible causes and any troubleshooters.
- b) List of operation anomalies:** list reporting operation anomalies which arose at times – according to one's own experience. Likely causes and troubleshootings are reported for each operation anomaly.

### 6.1.1 Alarm warning messages

**Warning message “Wait Pre-heating!”:**

It notifies the operator that the preset 2-hour pre-heating which automatically starts at every machine restart is in progress.

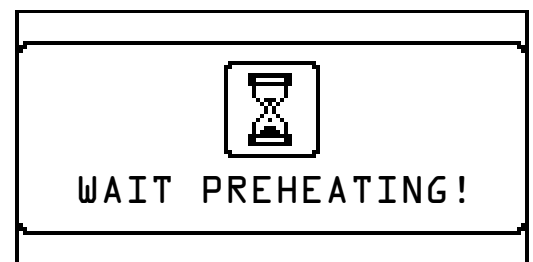

**Alarm “KO Work Area”:**

Alarm signal that notifies the operator that the safety pin installed on the worktop is not properly fitted. The worktop must be repositioned checking that the safety pin is correctly fitted.



**Alarm “Heat Engine”:**

Alarm signal. The thermal relay of the motor triggers when the motor is stressed to avoid more serious damages. To reset the machine, switch it off through the main switch and wait at least 30 seconds before restarting it.

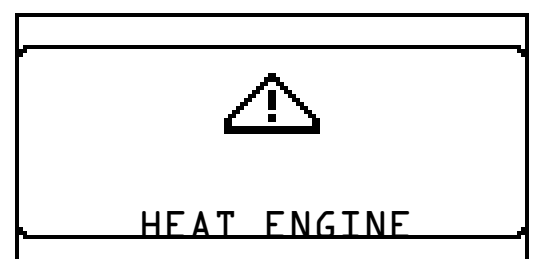

**Alarm “Heat Engine Screw MAXT”:**

Alarm signal that notifies the operator that the Archimedean screw probe detected a temperature exceeding the maximum allowable one to be set on the thermal regulator. It is advisable to contact the manufacturer or authorized retailer.



**IN THE PRESENCE OF AMBIENT TEMPERATURES EXCEEDING 50°C SOME OPERATION ANOMALIES MIGHT APPEAR AS “TANK PROBE MAXT”**

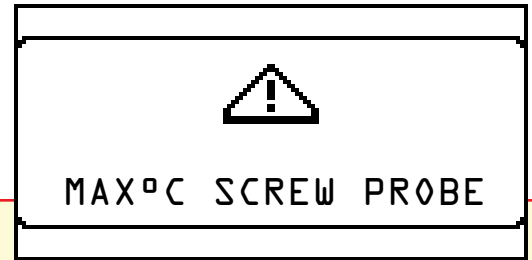

**Alarm “Heat Engine Tank MAXT”:**

Alarm signal that notifies the operator that the tank probe detected a temperature exceeding the maximum allowable one to be set on the thermal regulator. It is advisable to contact the manufacturer or authorized retailer.



**IN THE PRESENCE OF AMBIENT TEMPERATURES EXCEEDING 50°C SOME OPERATION ANOMALIES MIGHT APPEAR AS “TANK PROBE MAXT”.**

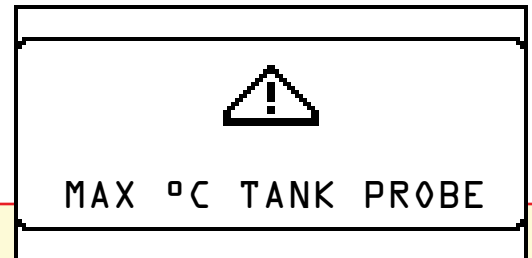

**Alarm “Sint. Tank Probe”:**

Alarm signalling the likely breakdown of the heating probe placed on the tank or a wrong power connection.

It is advisable to contact the manufacturer or authorized retailer.

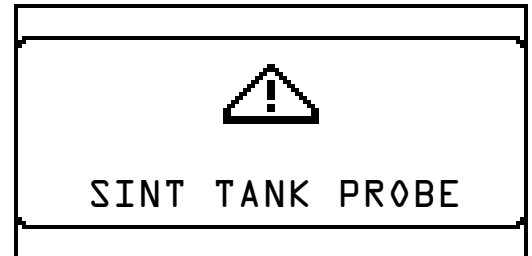

**Alarm “Screw Probe”:**

Alarm signalling the likely breakdown of the heating probe placed on the Archimedean screw or a wrong power connection.

It is advisable to contact the manufacturer or authorized retailer.

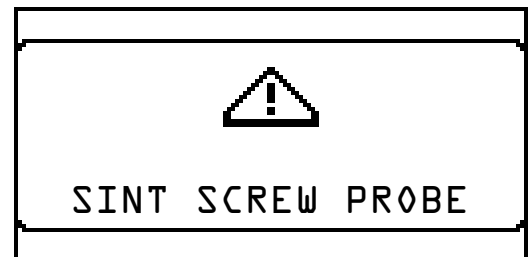

**DURING AN ALARM DISPLAY, THE OPERATOR CAN DISPLAY ONLY THE TEMPERATURE PAGE BY PRESSING ABY BUTTON. THE WARNING SYMBOL KEEPS FLASHING IN THE MIDDLE OF THE PAGE.**



### 6.1.2 Flowcharts

The machine can signal an operation anomaly through a condition.

Those anomalies are not always caused by mechanical troubles or electrical faults; they might be caused by operation parameters not correctly set or by the use of unsuitable products.

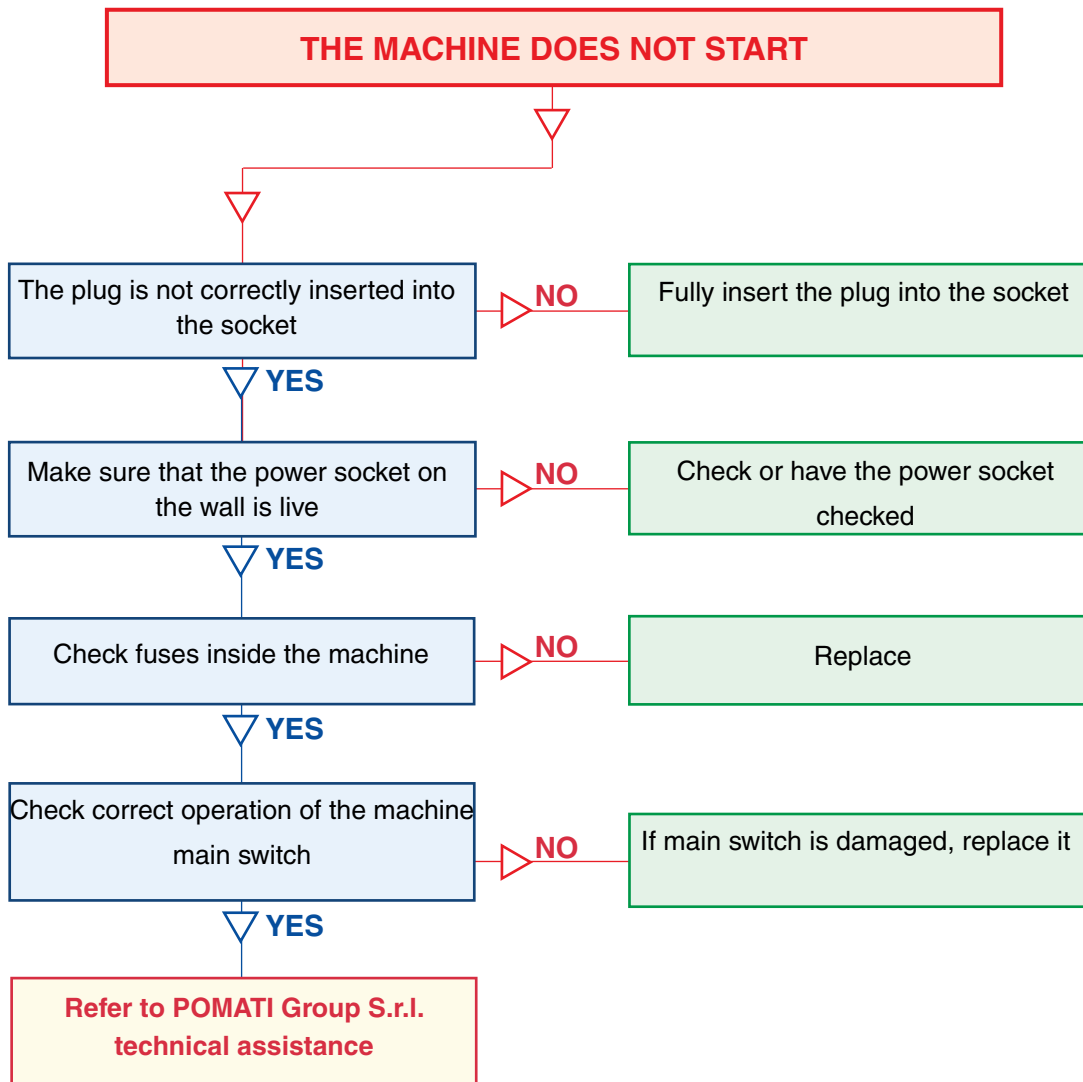

**THE MACHINE DOES NOT REACH THE CORRECT TEMPERATURE DURING HEATING**

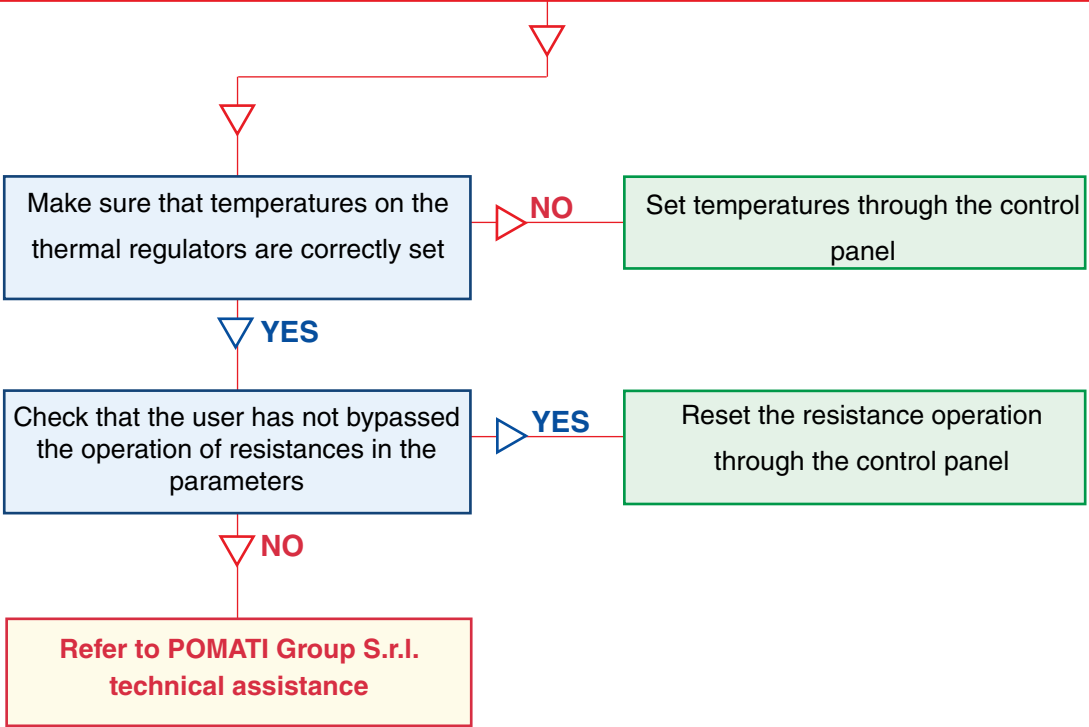

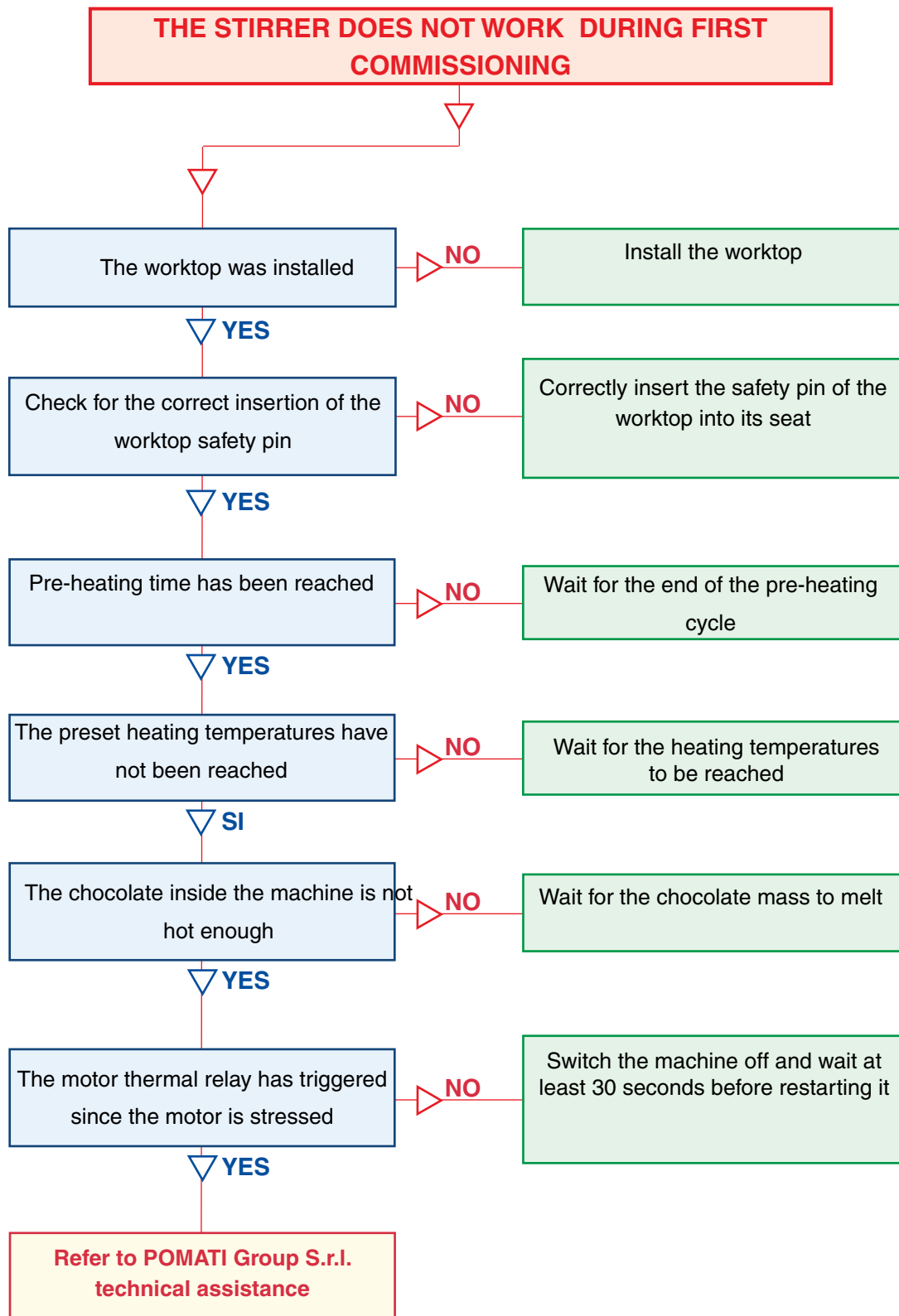

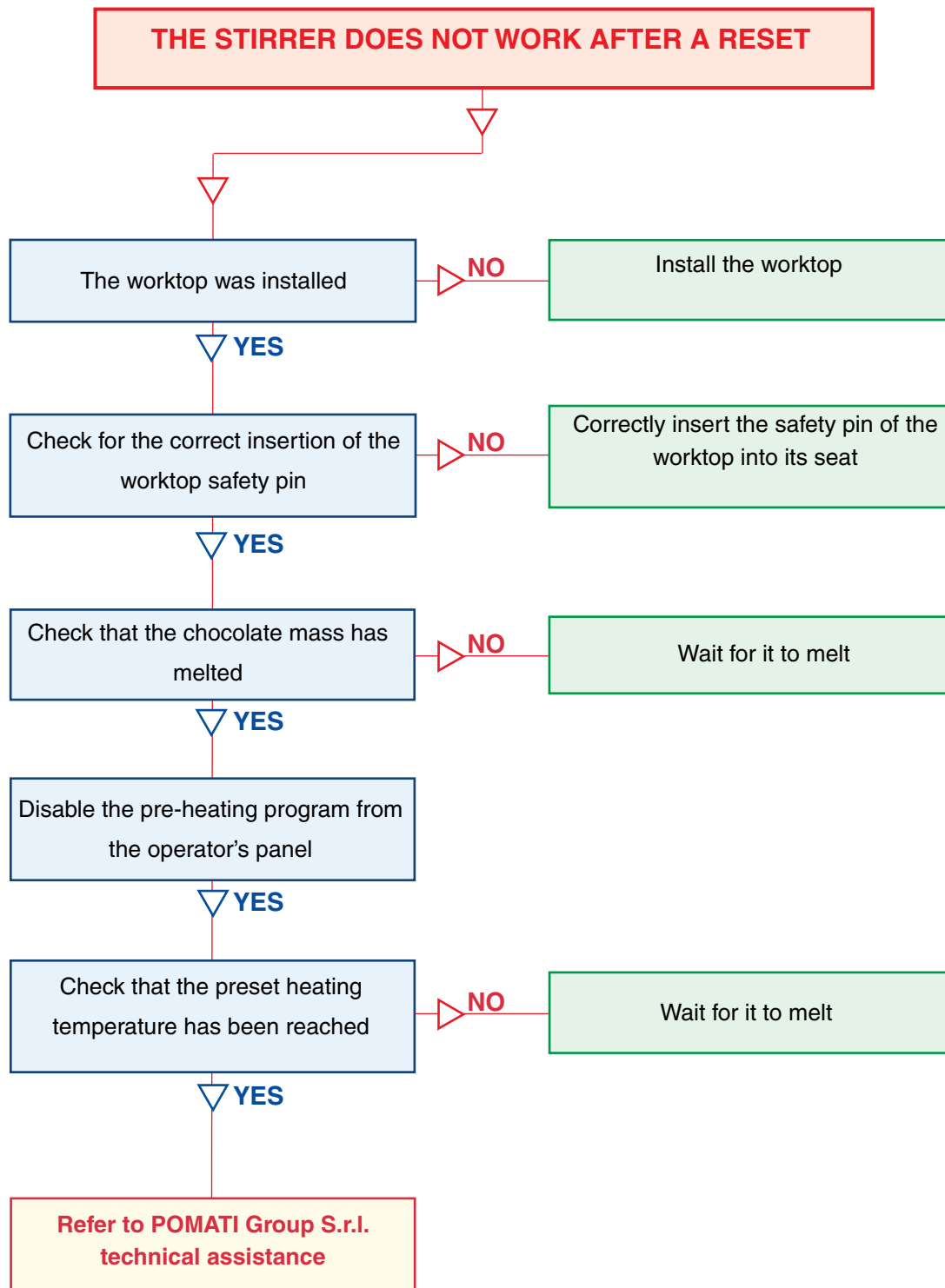



*This page intentionally left blank*

## 7.1 Spare parts

<i>Pos.</i>	<i>Code</i>	<i>Description</i>	<i>Quantity</i>
1	019056	Processing pipe	no. 1
2	002035	O-ring	no. 1
3	014045	Archimedean screw	no. 1
4	002152	Timing belt	no. 1
5	004142	Safety microswitch	no. 1
6	002047	Belt tensioner	no. 1
7	014007	Stirrer baffle	no. 1
8	020030	Worktop (for using in-counter machine)	no. 1
9	000035	Stirrer	no. 1
10	020047	Worktop (for using counter-top machine)	no. 1
11	004180	Control board	no. 1
12	014012	Vibration-damping device	no. 4

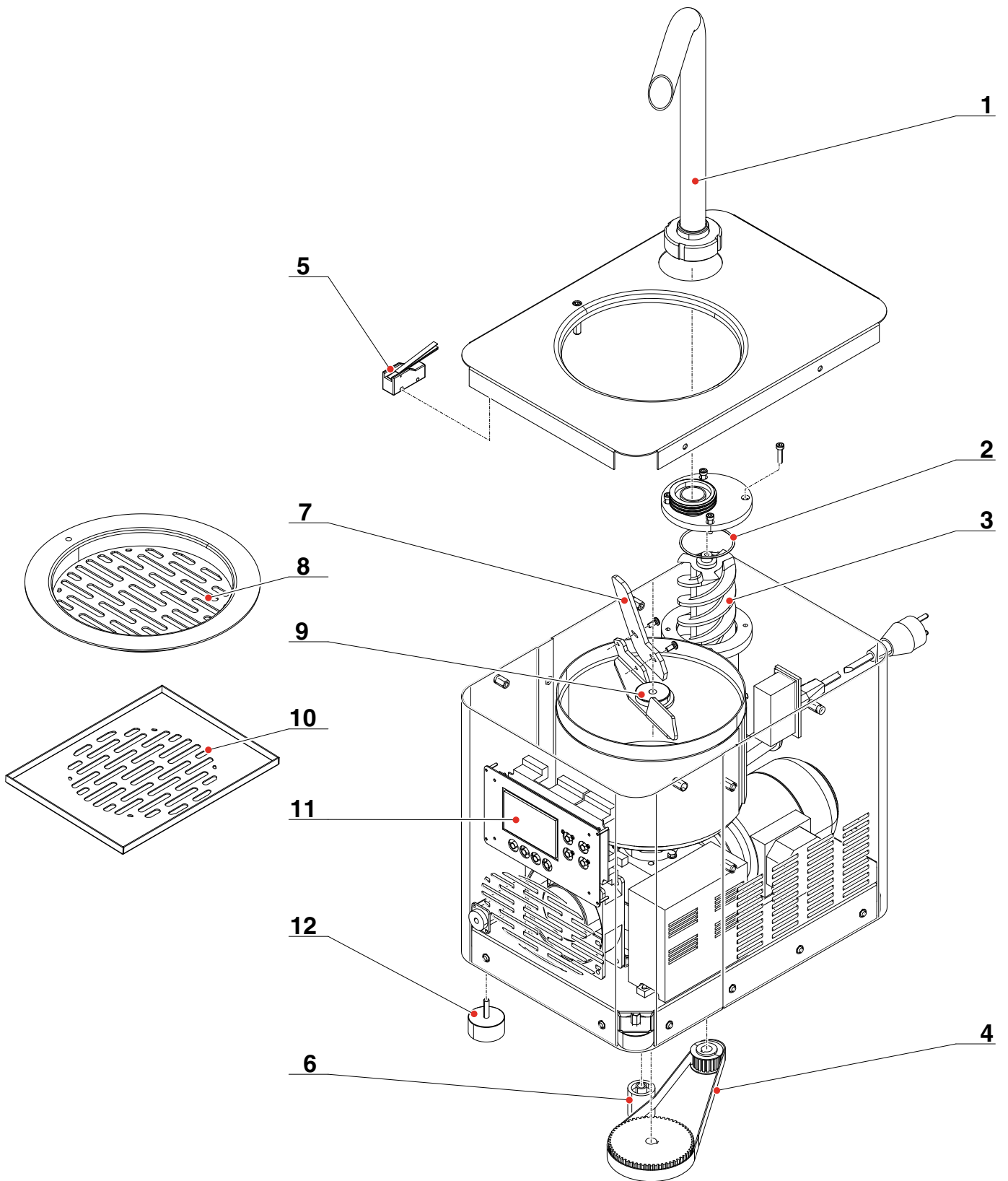

<b>Pos.</b>	<b>Code</b>	<b>Description</b>	<b>Quantity</b>
1	004019	Probe	no. 2
2	004197	Fan	no. 1
3	004009	Schuko plug+socket	no. 1
4	004093	Fuse	no. 2
5	012032	Discharge cap	no. 1
6	009028	Serial number plate	no. 1
7	009034	Electrical safety label	no. 1

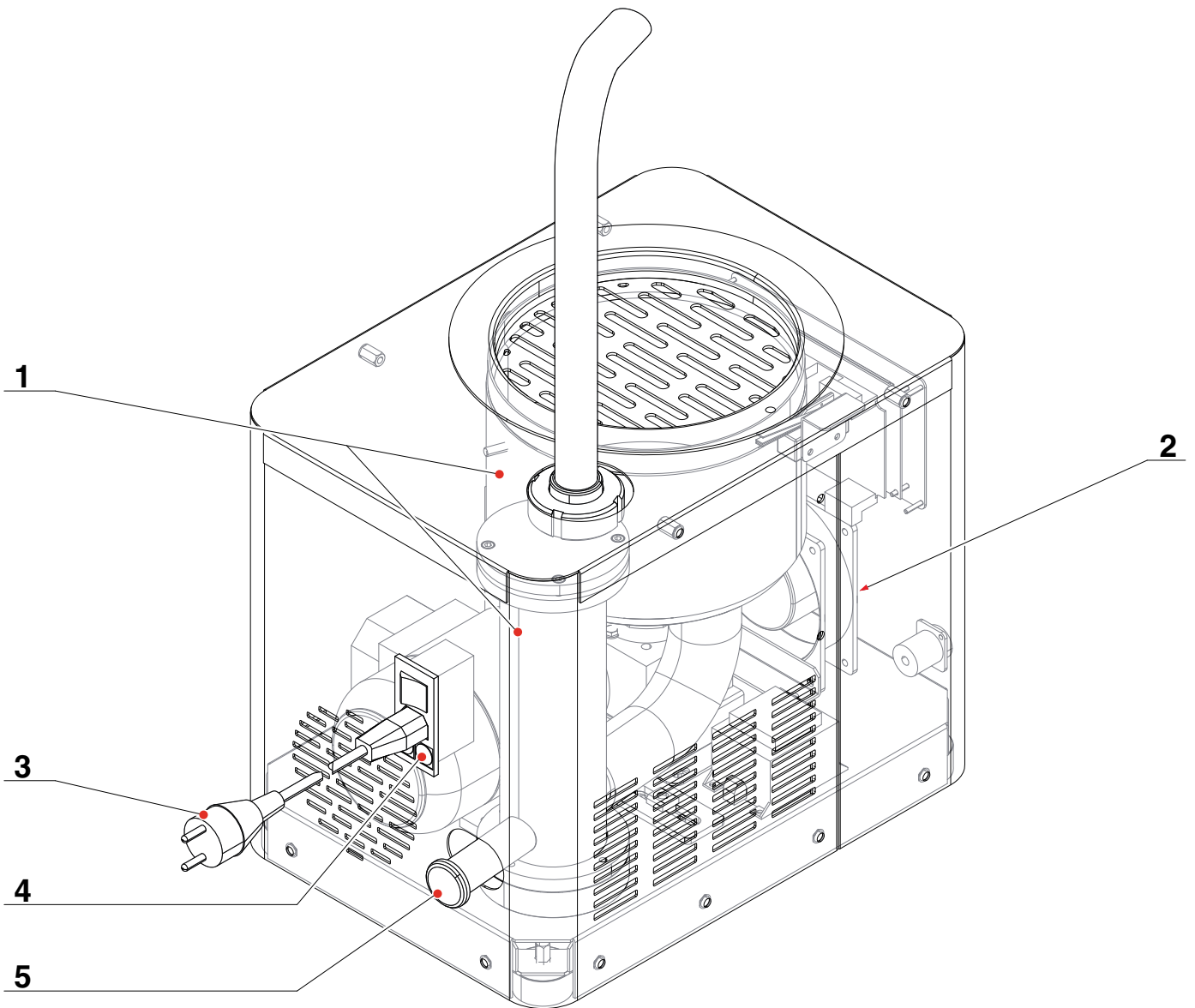

6

**POMATI**  
TECNOLOGIA NEL CIOCCOLATO

POMATI GROUP srl  
Uffici / Unità Produttiva:  
Via A. Moro, 14/16 - Zona Ind. Mirandolina  
26845 CODOGNÒ (LO) - ITALIA  
Tel. +39 0377 33092 r.a. - Fax +39 0377 34446  
E-mail: pomati@pomati.it

Modello	<input type="text"/>
Tipo	<input type="text"/>
Matricola	<input type="text"/>
Anno costr.	<input type="text"/>
Volt/Hz / Kw	<input type="text"/>

7



**ATTENZIONE  
WARNING**

**È VIETATO ESEGUIRE LAVORI SU APPARECCHIATURE  
ELETTRICHE E MECCANICHE SOTTO TENSIONE**

**IT IS FORBIDDEN TO DO WORK ON ELECTRICAL  
AND MECHANICAL DEVICES UNDER TENSION**

## 7.2 Wiring diagram

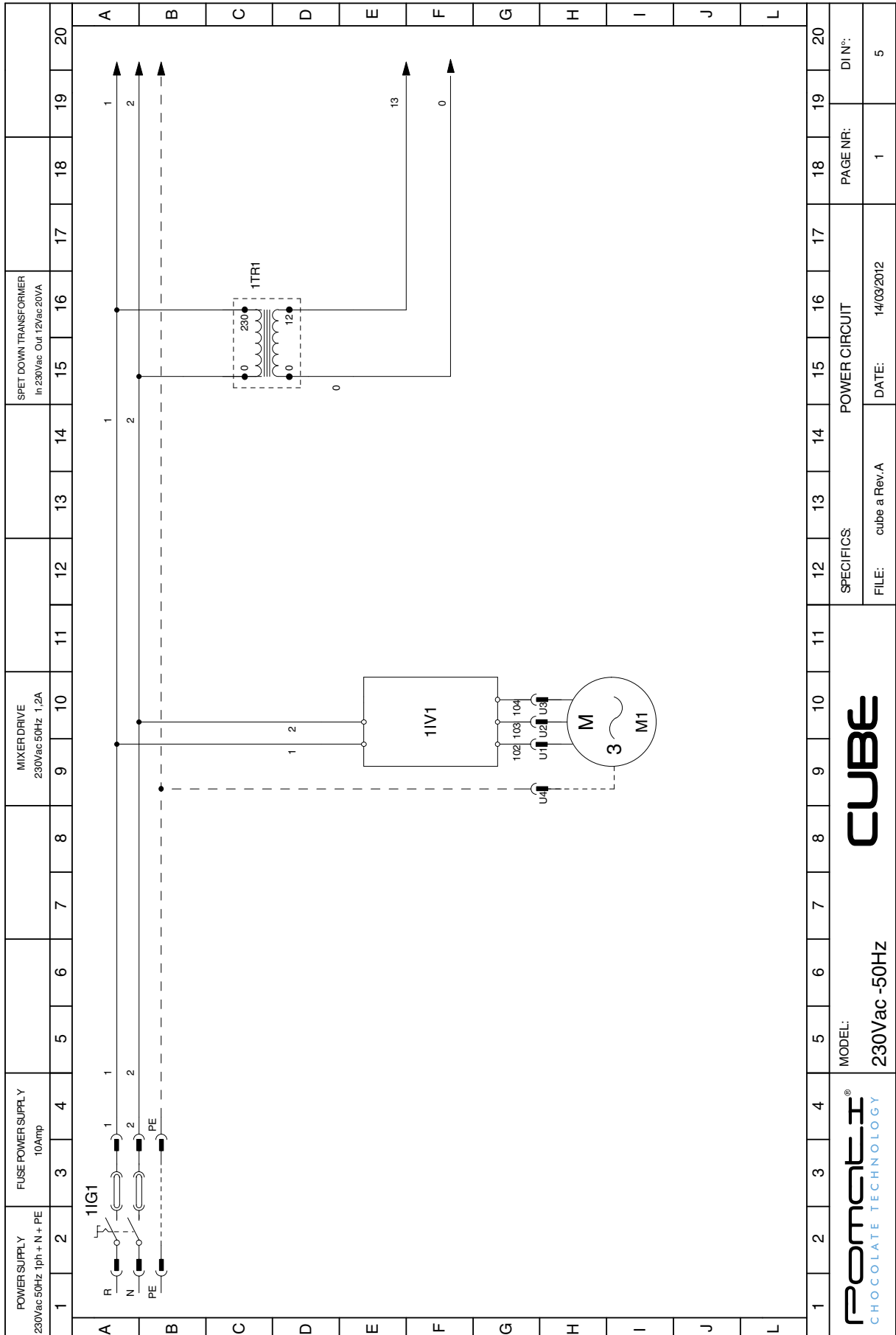



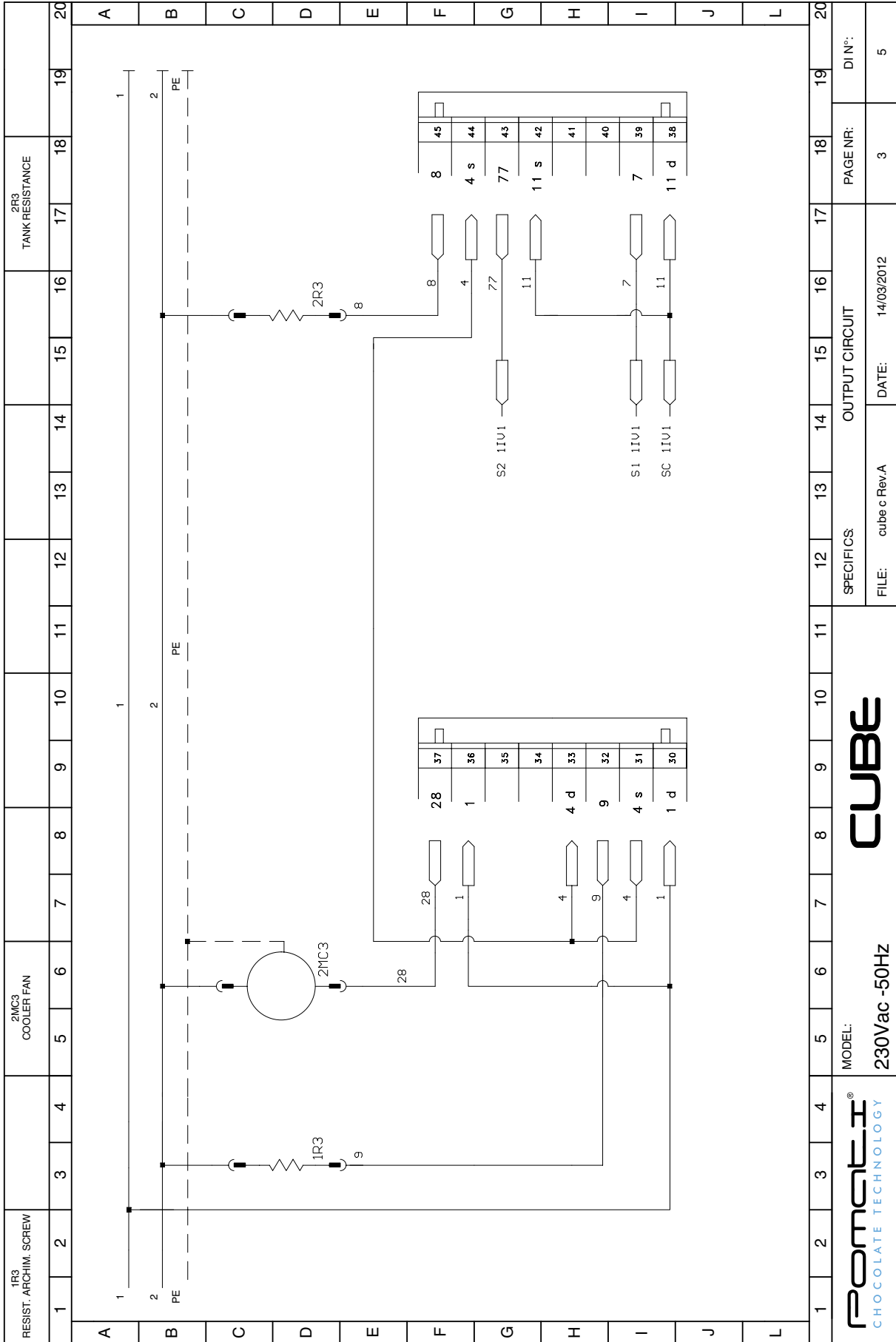











**POMATI**<sup>®</sup>  
CHOCOLATE TECHNOLOGY

Pomati Group S.r.l.  
via Aldo Moro 14/16  
Z.I. Mirandolina - 26845 Codogno (LO)

AFFRANCARE



**POMATI**<sup>®</sup>  
CHOCOLATE TECHNOLOGY

**CUBE**

**Warranty Certificate**



