



# MODEL DFG-100-ES Full-Size Convection Oven



Project \_\_\_\_\_

Item No. \_\_\_\_\_

Quantity \_\_\_\_\_

Standard depth baking compartment - accepts five 18" x 26" standard full-size baking pans in left-to-right positions.

All data is shown per oven section, unless otherwise indicated.

Refer to operator manual specification chart for listed model names.

### EXTERIOR CONSTRUCTION

- Full angle-iron frame
- Stainless steel front, top, and sides
- Dual pane thermal glass windows encased in stainless steel door frames
- Powder coated door handle with simultaneous door operation
- Triple-mounted pressure lock door design with turnbuckle assembly
- Ball bearing slide out front control panel for easy cleaning
- 1" solid block plus 1" mineral fiber insulation for a total of 2" of insulation

### INTERIOR CONSTRUCTION

- Double-sided porcelainized baking compartment liner (16 gauge)
- Stainless steel combustion chamber
- Single inlet blower wheel
- Five chrome-plated racks, eleven rack positions with a minimum of 1-5/8" (41mm) spacing
- Interior halogen lights

### OPERATION

- Direct fired gas system
- Electronic spark ignition control system
- Removable inshot burners
- Internal pressure regulator
- Manual gas service cut-off switch located on the front of the control panel
- Solid state thermostat with temperature control range of 200°F (93°C) to 500°F (260°C)
- Two speed fan motor
- 3/4 horsepower blower motor with automatic thermal overload protection
- Control area cooling fan

### STANDARD FEATURES

- SSD - Solid state digital control with LED display, Cook & Hold and Pulse Plus®
- 25" (635mm) adjustable stainless steel legs (for single units)
- 6" (152mm) adjustable stainless steel legs (for double sections)
- Three year parts and two year labor warranty
- Five year limited oven door warranty\*

\* For all international markets, contact your local distributor.

DFG-100-ES

### OPTIONS AND ACCESSORIES

(AT ADDITIONAL CHARGE)

#### ■ Legs/casters/stands:

- 6" (152mm) seismic legs
- 6" (152mm) casters
- 4" (102mm) low profile casters (double only)
- 25" (635mm) stainless steel stand w/rack guides
- 29" (737mm) stainless steel, fully welded open stand with pan supports

#### ■ Controls:

- SSI-D - Solid state infinite control w/digital timer
- SSI-M - Solid state infinite control w/manual timer
- SimpleTouch - NEW touchscreen control with ability to store and group recipes. Includes rack timing, Cook&Hold, Fan Delay, Fan Pulse, easy download for recipe writing on your laptop, and HAACP storage capability

#### ■ Gas hose w/quick disconnect restraining device:

- 48" (1219mm) hose
- 36" (914mm) hose
- Stainless steel oven liner
- Extra oven racks
- Stainless steel solid back panel
- Gas manifold (for double sections)
- Prison package (includes security control panel and stainless steel back)
- Flue connector
- Direct vent

### OPTIONS AND ACCESSORIES

(AT NO CHARGE)

- Solid stainless steel doors



**BLODGETT OVEN COMPANY**

[www.blodgett.com](http://www.blodgett.com)

42 Allen Martin Drive, Essex Junction, VT 05452  
Phone: (802) 658-6600 • Fax: (802) 864-0183



# MODEL DFG-100-ES

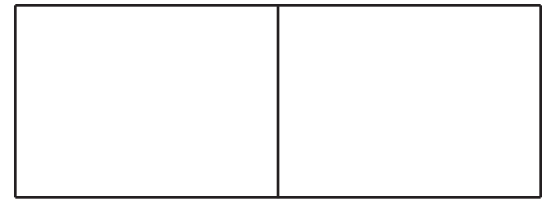

APPROVAL/STAMP

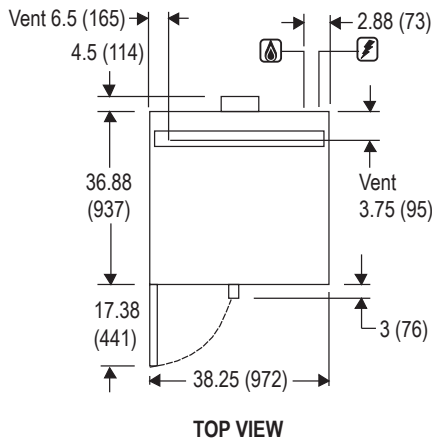

DIMENSIONS ARE IN INCHES (MM)

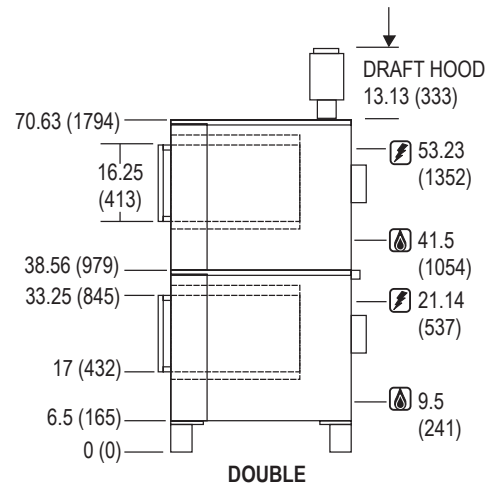
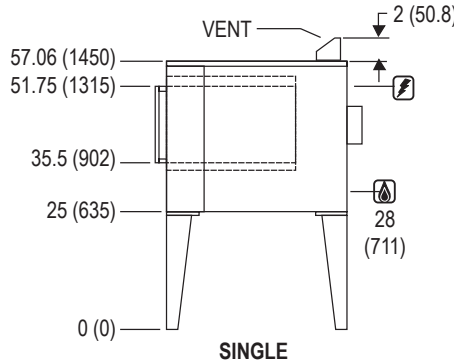

**SHORT FORM SPECIFICATIONS:** Provide Blodgett full-size convection oven model DFG-100-ES, (single/double) compartment. Each compartment shall have (porcelainized/stainless) steel liner and shall accept five 18" x 26" standard full-size bake pans. Stainless steel front, top and sides. Doors shall be (solid stainless steel/dual pane thermal glass windows) with single powder coated handle and simultaneous operation. Unit shall be gas heated with electronic spark ignition and shall cook by means of a direct fired system with a gas shutoff switch on the front of the control panel. Air in baking chamber distributed by single inlet blower wheel powered by a two-speed, 3/4 HP motor with thermal overload protection. Each chamber shall be fitted with two halogen lamps, five chrome-plated removable racks and removeable crumb trays. Control panel shall be recessed with solid state digital control with LED display, Cook & Hold and Pulse Plus. Provide three years parts, two year labor and five year door warranty. Provide options and accessories as indicated.

### DIMENSIONS:

Floor space 38-1/4" (972mm) W x 36-7/8" (937mm) D  
 Product clearance 0" from combustible and non-combustible construction  
 Interior 29" (737mm) W x 20" (508mm) H x 24-1/4" (616mm) D

### If oven is on casters:

Single Add 4-1/2" (114mm) to all height dimensions  
 Double Height dimensions remain the same  
 Double Low Profile Subtract 2.5" (64mm) from all height dimensions

### GAS SUPPLY:

3/4" NPT

### Manifold Pressure:

Natural 3.5" W.C. • Propane – 10" W.C.

### Inlet Pressure:

Natural 7.0" W.C. min. – 10.5" W.C. max.  
 Propane 11.0" W.C. min. – 13.0" W.C. max.

### MAXIMUM INPUT:

Single 45,000 BTU/hr (13.2 Kw)  
 Double 90,000 BTU/hr (26.4 Kw)

### POWER SUPPLY:

115 VAC, 1 phase, 8 Amp, 60 Hz., 2-wire with ground, 3/4 H.P., 2 speed motor, 1120 and 1680 RPM  
 6' (1.8m) electric cord set furnished on 115 VAC ovens only, 230V CE model, 1 phase, 3 Amp, 50 Hz., 2-wire with ground, 1/2 H.P., 1 speed motor, 1440  
 Blodgett recommends a Pass & Seymour, model 2097, GFCI due to the use of a variable frequency drive. Must be hard wired in some cases.

### MINIMUM ENTRY CLEARANCE:

Uncrated 32-1/16" (814mm)  
 Crated 37-1/2" (953mm)

### SHIPPING INFORMATION:

#### Approx. Weight:

Single 590 lbs. (268 kg)  
 Double 1095 lbs. (497 kg)

#### Crate sizes:

37-1/2" (952mm) x 43-1/2" (1105mm) x 51-3/4" (1315mm)

**NOTE:** The company reserves the right to make substitutions of components without prior notice

### BLODGETT OVEN COMPANY

www.blodgett.com • 42 Allen Martin Drive, Essex Junction, VT 05452 • Phone: (802) 658-6600 • Fax: (802) 864-0183