

SHALLOW DEPTH BASE MODEL REFRIGERATOR

MODEL: RA93SNBS

Natural Refrigerant R-290 Model

93" Shallow Depth Base Model Refrigerator with Solid Doors and 5.5" Backsplash



Heavy gauge #300 Series stainless steel top, stainless steel front and end panels, galvanized steel rear and grill and aluminum interior.



Options and Accessories

(upcharge and lead times may apply)

Stainless steel interior	Condensing unit left (standard on right)
Stainless steel back	Door & drawer locks
Stainless steel shelves	Pan Slides
Additional epoxy coated steel shelves	Front Breathing
Overshelves (single or double)	
Drawer in lieu of door section above the condensing unit*	
Drawers in lieu of doors (consult factory)**	

Consult factory for other model configurations, options and accessories.

*Drawer section above condensing unit holds (4) 6 x 6 2/3 x 6 pan

TWO TIER (larger section): (1) 12x20x6 pans per drawer

s



Toll-Free: 800-523-7138
Phone: 215-244-1400
Fax: 215-244-9579

539 Dunksferry Road
Bensalem, PA 19020
www.continentalrefrigerator.com

Project Name:

Model Specified:

Location:

Item No: Quantity:

AIA #: SIS #:

Standard Model Features

REFRIGERATION SYSTEM

- Performance rated refrigeration system
- Natural Refrigerant R-290 Model
- Unique forced air design utilizes fans (approx. every 12") across the entire back of unit for even distribution of cold
- Automatic, hot gas condensate evaporator
- Non-corrosive, plasticized fin evaporator coil
- Easily serviceable, slide out condensing unit
- Expansion valve system

CABINET ARCHITECTURE

- 2" non-CFC polyurethane foam insulation
- Smooth, polished chrome door handles
- Spring loaded, self closing doors
- Magnetic snap in Santoprene™ door gaskets
- Heavy duty, epoxy coated steel shelf
- Completely enclosed, vented and removable rear and side grills
- 5" casters

MODEL FEATURES

- Electronic control, off cycle defrost
- Refrigerated section with door above the condensing unit
- Field rehingeable doors

¹ R-290 refrigerant meets all federal and state regulatory requirements.

NOTE: Models come standard with a door over the condensing unit. A drawer over the condensing unit is an option.

APPROVAL:

Model Specifications

DIMENSIONAL DATA

Net Capacity (cubic feet)	25.6 (725 cu l)
Width, Overall (inches)	93 (2362 mm)
Depth, Overall (inches) (including handles & bumpers)	30 (770 mm)
Height, Overall (inches) (including 5" casters)	41 (1029 mm)
Shelf Area (square feet)	11.36 (1.1 sq m)
Number of Shelves	6
Number of Doors	Full 3 Half 1
Interior Depth (inches)	24 (610 mm)
Interior Height (inches)	26 (660 mm)
Interior Height (inches) (above condenser)	12.5 (318 mm)
Interior Width (inches)	89 (2261 mm)

REFRIGERANT DATA

Condensing Unit Size (H.P.)	1/4+
Capacity (BTU per hour)*	5260

ELECTRICAL DATA

Voltage (International)	115-60-1 (220-50-1)
Total Amps (International)	5.06 (3.4)
Defrost Amps	
10 ft. Cord/Plug [attached] (International)	Yes (No)

SHIPPING DATA

Weight (pounds)	470 (213 kg)
Height - Crated (inches)	43.75 (1111 mm)
Width - Crated (inches)	95 (2413 mm)
Depth - Crated (inches)	47 (1194 mm)

DRAWER PAN CONFIGURATIONS

TWO TIER (larger section): (1) 12x20x6 pans per drawer

* Rating @ +20°F evaporator, 120°F ambient
Figures in parentheses reflect metric equivalents rounded to the nearest whole unit.



© Copyright 2023. Continental Refrigerator.
A Division of National Refrigeration & Air Conditioning Products, Inc.

Model Plan Views

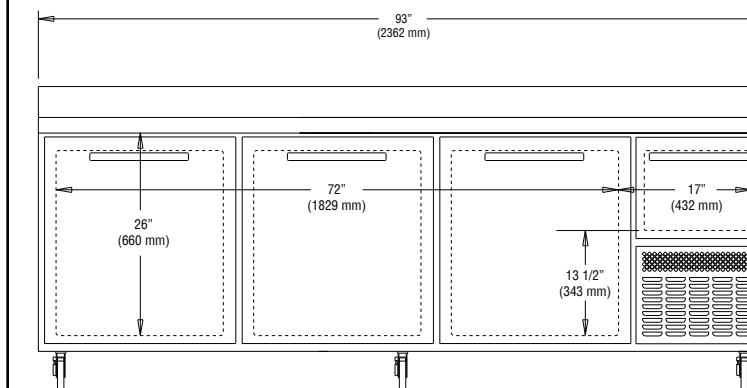

FRONT VIEW

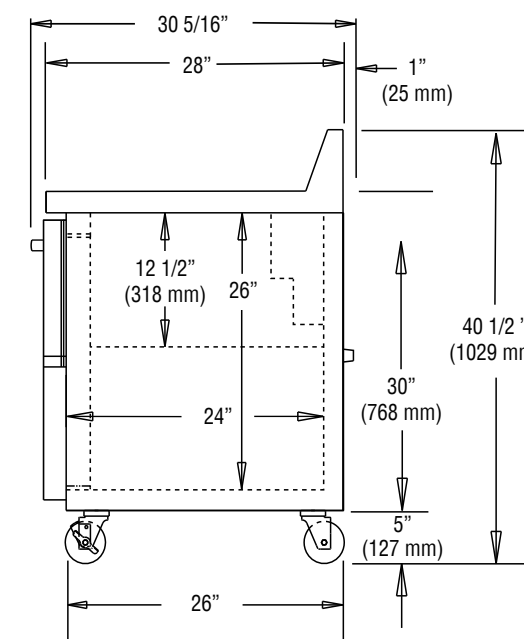

SIDE VIEW

IMPORTANT NOTE: If the cabinet is located directly against a wall, a minimum clearance of 3" is required on sides, front and rear.



www.continentalrefrigerator.com

Due to our continued efforts in developing innovative products, specifications subject to change without notice.

REVISED: 8/18/23