

SE12HC RxG

Pharmaceutical Refrigerator

Project Name: _____

Item #: _____ Quantity: _____



Width*	Depth**	Height***	Shelves	Cold Space™	Ship Weight	Ship Cube	Cooling Capacity	Electrical
23 7/8" 607 mm	24" 612 mm	62" 1575 mm	4	12	230 lbs 105 kg	28 cu. ft 0.79 m ³	1/4 HP	115V/3.1 Amp/60 Hz - Single Phase - NEMA 5-15P, Dedicated Circuit

** Add 1" (26mm) for Power Cord. *** Add 3/8" (10mm) for Threaded-In Levelers. Millimeters rounded up.

Premium Features



Cassette® Refrigeration



ProductTemp™



Digitally Controlled

 Finless Free&Clear™
Condenser Coil

 Automatic Stainless Steel
Condensate Control System

 Front Breathing
Refrigeration

Priority Air-Flow

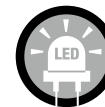

LED Lighting System

 HABCO
Insulated Glass

SE12HC RxG: Designed to enhance pharmaceutical storage and display experience to the highest standards of quality and performance.

Refrigeration:

- Self contained Cassette® forced-air refrigeration employs R290 hydrocarbon Natural Refrigerant within a sealed capillary tube system.
- Cassette® refrigeration is bottom-mounted and removable from the front for ease of maintenance. Refrigeration may be exchanged or upgraded without mechanic. Designed to hold 36°F to 46°F (2.2°C - 7.7°C).
- Equipped with Energy Efficient Digital Controller featuring visual/audible product protection alarm.
- Priority, directed air flow provides optimum cooling and energy efficiency within cabinet and exclusively at front of unit for optimized heat exchange ventilation.
- Finless, Free&Clear™ Condenser Coil maximizes air-flow over the compressor, reduces energy consumption and is non-clogging.
- Automatic, stainless steel condensate control system.
- Technologically advanced ProducTemp™ provides exterior product temperature display. Displays to a resolution of 0.1°.
- Quality, self-lubricating and sealed motors with streamlined air-flow provide quieter yet robust refrigeration.



Cabinet:

- Exterior – durable appliance white.
- Interior – NSF approved white aluminum liner with stainless steel floor.
- Ergonomic raised interior floor.
- Space Saving Design – air ventilation exclusively from the front of unit.
- Insulation – cabinet is foamed-in-place with eco-conscious, polyurethane insulation.
- Heavy duty thread-in leveler legs.

Doors:

- Self Closing Swing Doors feature hold-open position, spring back protection and are reversible on-location.
- Magnetic gaskets are single piece bead-mount construction easily removable for cleaning.
- Heat Reflecting HABCO Insulated Safety Glass with black extruded frame.
- Integrated, injection molded pocket handle(s).

Lighting:

- Energy Efficient LED Lighting System for sparkling Illuminated Interior Display, on Switch.

Storage:

- Four (4) white coated shelves 19 1/2"W x 18"D (496mm x 458mm), are NSF approved.
- Heavy duty aluminum shelving pilasters will not peel or chip adjustment of 1/2" (13mm) increments.

Electrical:

- Factory power cord installed for connection to a sole-use (dedicated) 115V/60Hz/1-Phase, 15 Amp circuit.

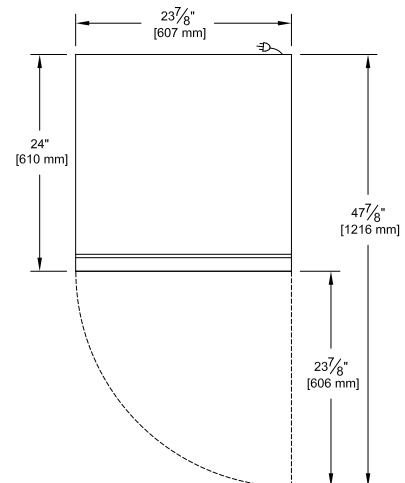
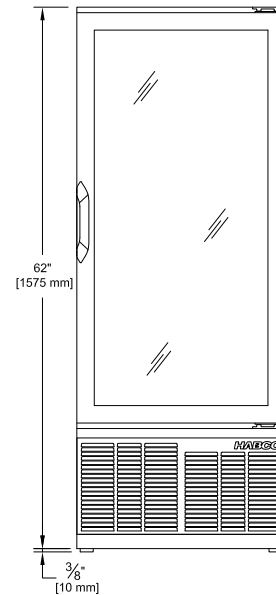

HABCO MANUFACTURING INC. 501 GORDON BAKER ROAD, TORONTO, ONTARIO, CANADA, M2H 2S6
Toll Free CAN: 1-800-387-5398 USA: 1-800-448-0244 Fax: 416-491-6982 www.habcomfg.com