

# Digital Convection Oven

model #: **GS1125**



## DIMENSIONS

Equipment (w x d x h) . . . . . 23<sup>5</sup>/<sub>8</sub>" x 28" x 21"  
 Equipment Weight . . . . . 104 lbs  
 Shipping Weight. . . . . 107 lbs

## CAPACITY

4- 18" x 13" Half Size Pans

Great for any size kitchen that needs to bake in small batches. This half size convection oven is the perfect space-saving solution for a tight kitchen. The added steam feature helps keep your food moist and digital controls make managing your cooking even easier.

## STANDARD FEATURES

- Set temperature from 200°F to 500°F
- Set cooking time up to 9 hours and 59 minutes or "infinite" time to adjust cooking duration manually
- 2 cooking options available:
  - Convection cooking
  - Convection cooking with humidity/steam
- Humidity/steam set in manual or automatic mode (from 10% to 100%)
- 4 cooking steps available
- Possibility to set a delayed start of the cooking cycle up to 9 hours and 59 minutes
- Possibility to set a temperature and humidity/steam maintenance cycle
- Automatic preheating for programmed cooking cycles
- Cooking chamber entirely made with stainless steel
- Oven shell entirely made with stainless steel
- Inspection door to facilitate cleaning operations
- Reversing motor to guarantee cooking uniformity
- Recessed gasket to guarantee chamber cooking seal



# Digital Convection Oven

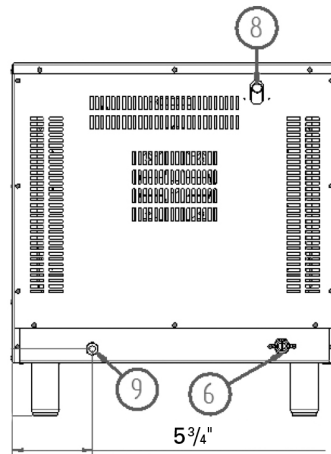
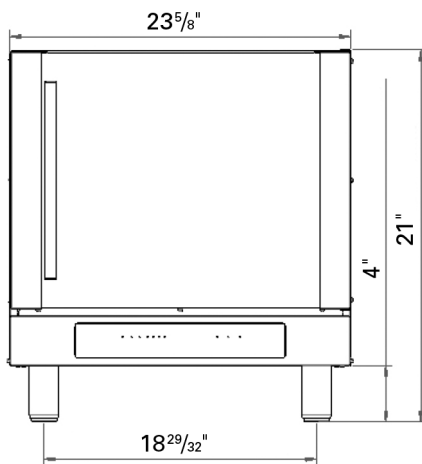

- 6. Softened Water Inlet  
(Threaded Electrovalve 3/4")
- 8. Steam Exhaust
- 9. Cable Gland for Power Supply

Model #	Description	Volts	Watts	Amps	Plug Configuration
GS1125	Digital Convection Oven, w/Steam, 1/2 Size, 4-Shelf	208/240	2900	13.9/12.1	NEMA 6-20P

### INSTALLATION REQUIREMENTS:

- The oven must be positioned on a leveled surface
- Hot surfaces must comply with the minimum distances from the oven:
 

LEFT SIDE:	19 3/4"
RIGHT SIDE:	19 3/4"
REAR PANEL:	19 3/4"
- Other surfaces must comply with the minimum distances from the oven:
 

LEFT SIDE:	4"
RIGHT SIDE:	4"
REAR PANEL:	4"