

CLASSIC GNG

Grab and Go Showcase

STANDARD FEATURES

- Double panel side glasses
- LED lighting on each shelf
- Dixell digital control
- Self contained
- Remote (model A90X only)
- Stainless steel foam in place bottom and top
- Adjustable feet
- Cases ship standard unfinished front and stainless steel skin sides



OPTIONS

- Model A90X - self contained
- Stainless steel side panels in lieu of glass
- Roll down locking shutter
- Epoxy RAL color interior
- Remote air cooled or water cooled
- RAL color/laminate front and side panels
- Condensate pan
- Casters



CLASSIC GRAB AND GO					
TECHNICAL FEATURES		MODELS			
		CLASSIC GNG 1000	CLASSIC GNG 1300	CLASSIC GNG 1500	CLASSIC GNG 1700
External Dimensions (L-D-H)	Inches	39 3/8" - 37 5/8" - 52 1/16"	51 3/16" - 37 5/8" - 52 1/16"	59 1/16" - 37 5/8" - 52 1/16"	66 15/16" - 37 5/8" - 52 1/16"
	Inches-MM	1000 - 956 - 1322	1300 - 956 - 1322	1500 - 956 - 1322	1700 - 956 - 1322
Crated Dimensions (L-D-H)	Inches	46" - 43" - 60"	57" - 43" - 60"	66" - 43" - 60"	73" - 43" - 60"
	Inches-MM	1168 - 1092 - 1524	1447 - 1092 - 1524	1676 - 1092 - 1524	1854 - 1092 - 1524
BTU's @ +14°F Evap Temperature	BTU'S	4200 BTU'S	6222 BTU'S	6720 BTU'S	7225 BTU'S
Power Supply	(V/Ph/Hz)	220/1/60	220/1/60	220/1/60	220/1/60
Amperage	(A)	8A	9A	12A	15A
Operating Temperature	°F	+15°F	+15°F	+15°F	+15°F
Net Weights	Kg/Lb	130Kgs / 286Lbs	200Kgs / 440Lbs	240Kgs / 528Lbs	279Kgs / 616Lbs
Crated Weights	Kg/Lb	145Kgs / 319Lbs	220Kgs / 484Lbs	255Kgs / 561Lbs	289Kgs / 638Lbs

* DIMENSIONS ARE WITHOUT SIDE PANELS * REMOTE APPLICATION - CONDENSING UNIT SOLD SEPERATELY * FLOOR SINK RECOMMENDED ON THESE MODELS

CLASSIC GRAB AND GO					
TECHNICAL FEATURES		MODELS			
		CLASSIC GNG 2000	CLASSIC GNG A30	CLASSIC GNG A90	CLASSIC GNG A90X
External Dimensions (L-D-H)	Inches	78 3/4" - 37 5/8" - 52 1/16"	64 11/16" - 37 5/8" - 52 1/16"	65" - 37 5/8" - 52 1/16"	70 13/16" - 37 5/8" - 34 5/8"
	Inches-MM	2000 - 956 - 1322	1643 - 956 - 1322	1651 - 956 - 1322	1798 - 956 - 879
Crated Dimensions (L-D-H)	Inches	84" - 43" - 60"	70" - 43" - 60"	70" - 43" - 60"	77" - 43" - 41"
	Inches-MM	2133 - 1092 - 1524	1778 - 1092 - 1524	1778 - 1092 - 1524	1955 - 1092 - 1041
BTU's @ +14°F Evap Temperature	BTU'S	8820 BTU'S	6720 BTU'S	8950 BTU'S	12,600 BTU'S
Power Supply	(V/Ph/Hz)	220/1/60	220/1/60	220/1/60	220/1/60
Amperage	(A)	16A	15A	17A	2A
Operating Temperature	°F	+15°F	+15°F	+15°F	+15°F
Net Weights	Kg/Lb	300Kgs / 660Lbs	240Kgs / 528Lbs	300Kgs / 660Lbs	344Kgs / 760Lbs
Crated Weights	Kg/Lb	330Kgs / 726Lbs	255Kgs / 561Lbs	330Kgs / 726Lbs	374Kgs / 826Lbs



* DIMENSIONS ARE WITHOUT SIDE PANELS * REMOTE APPLICATION - CONDENSING UNIT SOLD SEPERATELY * FLOOR SINK RECOMMENDED ON THESE MODELS

* Manufacturer reserves the right to change specifications without notice. Not responsible for error and omissions.



361-367 Beach Road, Burlingame, CA 94010
 Tel: 855.885.2400 | 650.342.2400 | Fax: 650.342.7400
 sales@oscartek.com | www.oscartek.com



ELECTRICAL LEGEND	
	1/4" DRAIN
	REFRIGERATION LINES: 3/8" LIQUID, 1/2" SUCTION
	POWER

SECTION VIEW

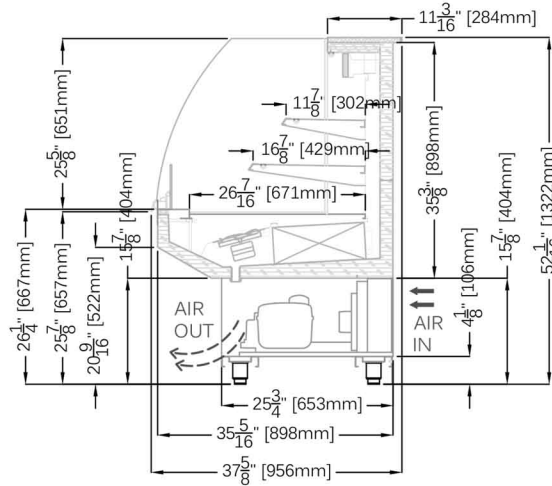

SECTION VIEW GNG A90X

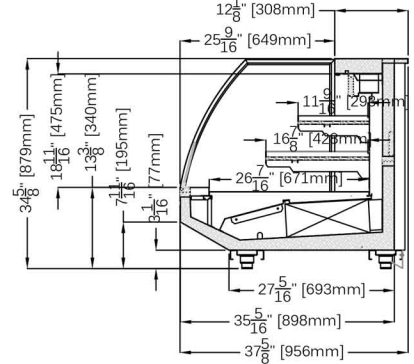

PLAN VIEWS:

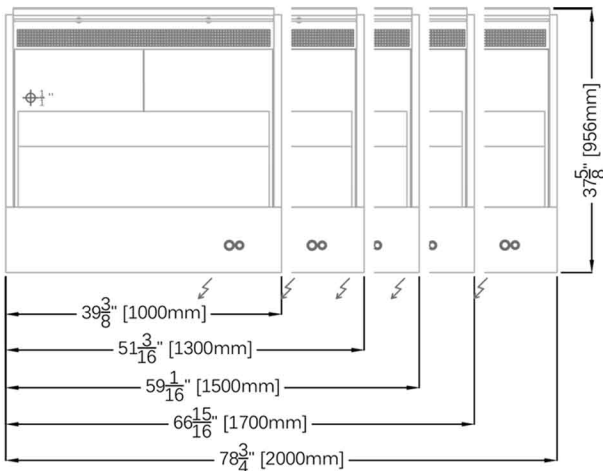

GNG A30

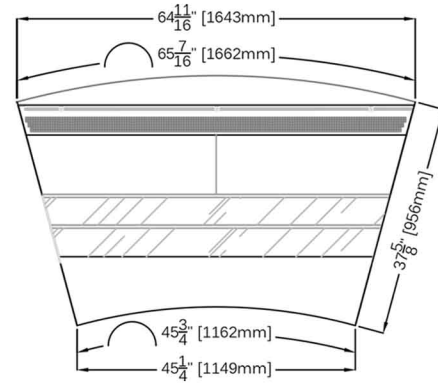

GNG A90

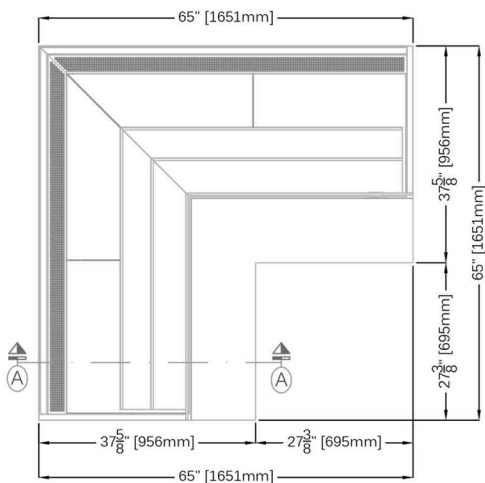

GNG A90X

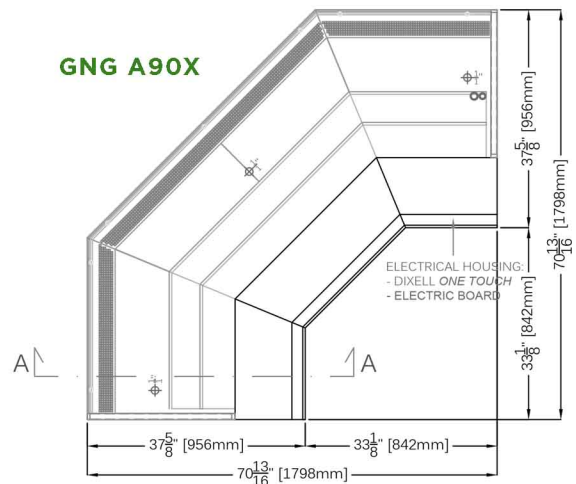

* Manufacturer reserves the right to change specifications without notice. Not responsible for error and omissions.

CLASSIC GNG

Grab and Go Showcase

FRONT ELEVATIONS (CUSTOMER SIDE):

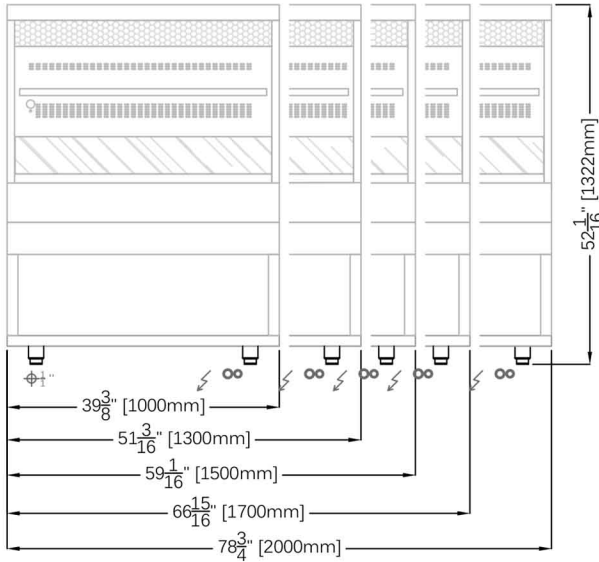

GNG A30

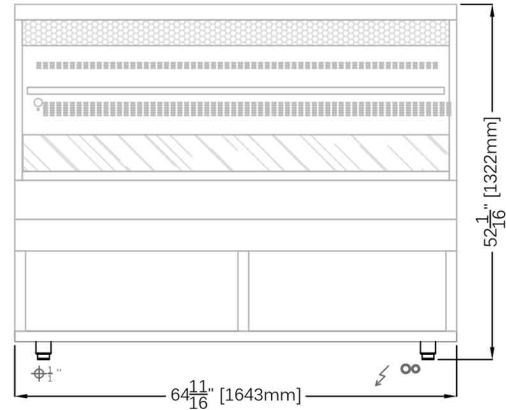

SECTION A-A GNG A90

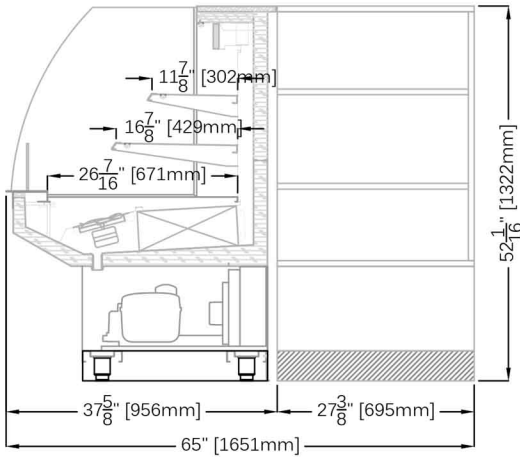

SECTION A-A GNG A90X

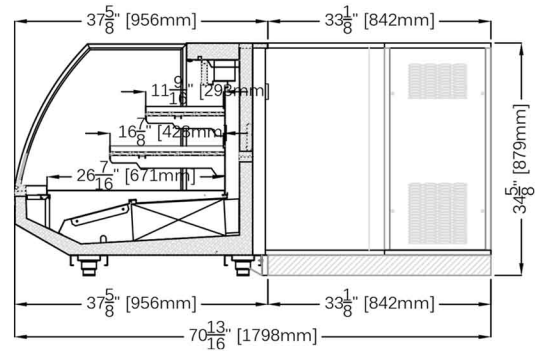

FRONT ELEVATION (CUSTOMER SIDE) GNG A90X

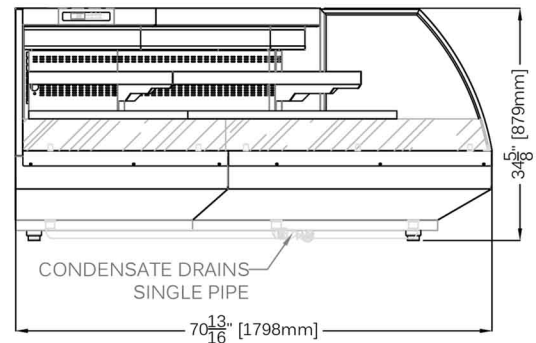

* Manufacturer reserves the right to change specifications without notice. Not responsible for error and omissions.



361-367 Beach Road, Burlingame, CA 94010
Tel: 855.885.2400 | 650.342.2400 | Fax: 650.342.7400
sales@oscartek.com | www.oscartek.com

