



SL-66-QSCHP-4-F shown with options: (OP) offset panels, (TEW) top width extension, and tempered glass protector.



U.L. Sanitation Classified to NSF Standards

- Switch from hot to cold in a matter of minutes
- Individual well flexibility
- Labor-saving, easy-to-clean design

Specifications

Top - Top to be 30" wide and fabricated from a minimum of 14 ga. stainless steel with square turndown on all sides and corners fully welded, ground and polished. Top to have #4 satin finish and with all edges having a #7 hi-lite finish.

Body (F) - Body to be seamless molded fiberglass (F.R.P.) with smooth exterior surfaces and rounded corners. To be constructed by a hand lay-up process with four layers of 1.5 oz continuous strand fiberglass mat, plus a 24 oz layer of woven roving on the bottom for added strength. Fiberglass to be flame retardant per specification

ASTM E-162 having a flame spread of 25% or less. Body interior to be reinforced at each end with 4" wide, 12 gauge galvanized channels welded to form integral "U" frame for maximum stress relief.

Casters - 5" diameter, ball bearing, swivel type casters to be non-marking and with brakes on all wheels. Casters to be mounted with exterior and interior bracing for maximum stress relief.

General Specifications - Counter to include convertible Hot/Cold/Freeze wells. Wells to be individual 12" x 20" opening. Well to have the ability to either; heat, refrigerate, or hold frozen product. All wells to be individually operated

with separate controls and drains. Unit to be constructed of 14 gauge 304 stainless steel, welded, ground and polished with a thermal break provided between the top and refrigerated interior. Interior pan to be 18 gauge 304 stainless steel, fully welded, ground and polished with a 3/4" open drain. Unit to be fully insulated with 2-1/2" to 3" urethane insulation. The exterior jacket to be constructed of heavy gauge stainless steel. Refrigeration system to be a hermetically sealed compressor operating on R-449A (HFC) refrigerant, and will include controls. Well to also operate as an energy efficient hot food well using a 500 watt heat source digitally controlled.

Options

Top Options

- Height other than std. 36" (specify ____)
- (RE) Recess for 18" x 26" pans
- (FF) End Drop Shelf

Above the Top

- (GA) Sloped Front Protector, Adjustable
- (GAG) Sloped Front Protector - Adjustable - Glass Top Shelf
- (GC) Sloped Front Protector, Glass Clips
- (GCG) Sloped Front Protector - Glass Clips - Glass Top Shelf
- (M) Buffet Shield Single Service Hinged

- (N) Buffet Shield Double Service Hinged
- (I) 2 tier Display Shelf, single service
- (I2) 2 tier Display Shelf, double service
- (RR) LED Lights
- (S) Heat lamp
- (U) Heat lamp with lights

Tray Slide/Cutting Board Options

- (A) Beaded, stainless steel tray slide
- (B) Flat Surface, stainless steel tray slide
- (C) Tubular stainless steel tray slide
- (D) 8" wide Stainless Steel cutting board
- (E) 8" wide Richlite® composite cutting board

Base Options

- (NN) Fiberglass Door Panels
- (MM) Vertical Trim Strips
- (SS) Stainless Steel Legs
- (OP) Offset Panels
- Custom Body Color (specify RAL #____)
- S/S Toe Kick

Plumbing & Electrical Options

- (DD) Convenience outlet, flush
- Alternate Drain Location _____
- Water fill Faucet
- Auto Water fill Valve

Project: _____

Item: _____

Quantity: _____

Date: _____

Models	Length	Capacity
<input type="checkbox"/> SL-36-QSCHP-2-F	36 3/8"	2 wells
<input type="checkbox"/> SL-50-QSCHP-3-F	50 3/8"	3 wells
<input type="checkbox"/> SL-66-QSCHP-4-F	66 3/8"	4 wells
<input type="checkbox"/> SL-74-QSCHP-4-F	74 3/8"	4 wells
<input type="checkbox"/> SL-84-QSCHP-5-F	84 3/8"	5 wells
<input type="checkbox"/> SL-96-QSCHP-6-F	96 3/8"	6 wells

Standard Features

- ✓ 30" wide 14 gauge stainless steel top
- ✓ Individual solid state digital controls
- ✓ Molded fiberglass body
- ✓ Single power source
- ✓ Manifold drains
- ✓ 5" Locking Swivel Casters
- ✓ Cam operated line up lock

Hot/Cold/Freeze Food Table Powered by QuickSwitch™

Molded Fiberglass (F)



Hot/Cold/Freeze Food Table Powered by QuickSwitch™
Molded Fiberglass (F)

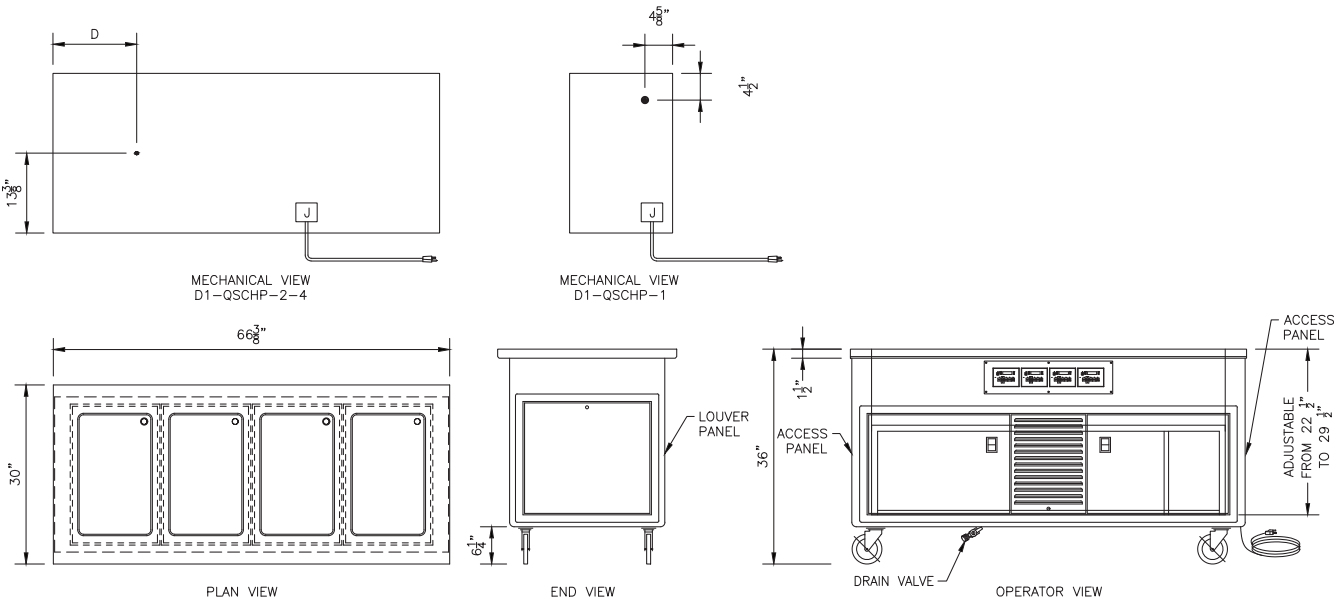

Model #	L	Pans	120V/1		120/208V/1		120/240V/1		Approximate Ship Weight
			Amps	Plug	Amps	Plug	Amps	Plug	
SL-36-QSHP-2-F	36 3/8"	2	12.7	5-15P	9.6	14-20P	10.0	14-20P	455 lbs.
SL-50-QSHP-3-F	50 3/8"	3	18.2	5-30P	12.0	14-20P	12.7	14-20P	645 lbs.
SL-66-QSHP-4-F	66 3/8"	4	23.7	5-30P	14.4	14-20P	15.5	14-20P	670 lbs.
SL-74-QSHP-4-F	74 3/8"	4	23.7	5-30P	14.4	14-20P	15.5	14-20P	790 lbs.
SL-84-QSHP-5-F	84 3/8"	5	30.9	5-50P	21.6	14-30P	22.7	14-30P	1125 lbs.
SL-96-QSHP-6-F	96 3/8"	6	36.4	5-50P	24.0	14-30P	25.4	14-50P	1280 lbs.

Décor Options (Contact Factory)

- Vinyl Graphic Wrap
- Body Decal
- Canopy (specify style & color)
- Over-structure with signage & lights (specify _____)
- Stand Off Panel (specify materials _____)

Units to be UL listed and shall bear the UL classified EPH label for sanitation meeting all NSF4 and NSF7 requirements.

Compressor standard location in center of counter.

Note: To ensure proper operation, adequate airflow must be provided.

We reserve the right to change specifications and product design without notice. Such revisions do not entitle the buyer to corresponding changes, improvements, additions or replacement for previously purchased equipment.

All equipment to be built in accordance with the Underwriters Laboratories, Inc. and the National Sanitation Foundation, Inc. standards and shall bear the Underwriters Laboratories, Inc. listing label for safety and the Underwriters Laboratories classification label for sanitation.

A.I.A. File No. 00-0-00

SIS No. 00-0-00

REV 5/12/22

LTI, Inc.
1947 Bill Casey Parkway
Jonesboro, GA 30236

(888) 584-2722
lowtempind.com



Changing
how food is served.™