

Specification Sheet

Short Form Specifications

Blendport worktables, Deluxe series, model _____.
Top constructed of 16 gauge 300 series stainless steel with 1½" roll on front, 4½" backslash, and sides turned down 90°. Open front with 1¼" O.D. galvanized tubular crossbracing on sides and rear. Top reinforced with hat channels and sound deadened. Constructed with uni-lok® patented gusset system with the gussets recessed into the hat channels to reduce lateral movement. Legs are 1½" O.D. galvanized tubing, with galvanized gussets and 1" hi-impact plastic bullet feet.

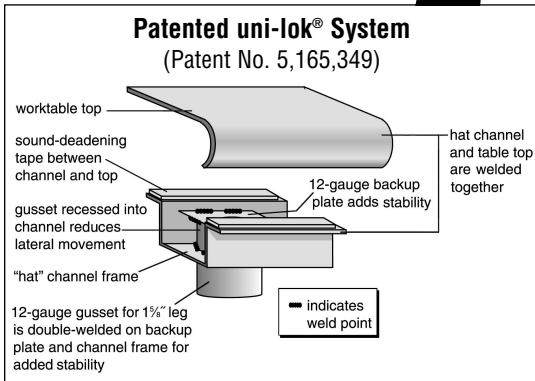

Item No.: _____
Project No.: _____
S.I.S. No.: _____

Worktables with Backslash and Galvanized Tubular Base —Deluxe Series

MODELS:

- | | |
|--|--|
| <input type="checkbox"/> BPT-2424GTEB-BS | <input type="checkbox"/> BPT-3024GTEB-BS |
| <input type="checkbox"/> BPT-2430GTEB-BS | <input type="checkbox"/> BPT-3030GTEB-BS |
| <input type="checkbox"/> BPT-2436GTEB-BS | <input type="checkbox"/> BPT-3036GTEB-BS |
| <input type="checkbox"/> BPT-2448GTEB-BS | <input type="checkbox"/> BPT-3048GTEB-BS |
| <input type="checkbox"/> BPT-2460GTEB-BS | <input type="checkbox"/> BPT-3060GTEB-BS |
| <input type="checkbox"/> BPT-2472GTEB-BS | <input type="checkbox"/> BPT-3072GTEB-BS |
| <input type="checkbox"/> BPT-2484GTEB-BS | <input type="checkbox"/> BPT-3084GTEB-BS |
| <input type="checkbox"/> BPT-2496GTEB-BS | <input type="checkbox"/> BPT-3096GTEB-BS |

Tabletop

- Patented uni-lok® gusset system (patent #5,165,349): gussets are recessed into hat channel, reducing lateral movement.
- Top reinforced with welded-on hat channel.
- Sound-deadened between top and channels.
- 4½" (114mm)-high 90° backslash with 1" (25mm) turn at 90°.
- 1½" (38mm)-diameter 180° rolled edge on front. Ends are turned down 90°, providing for flush installations when required.
- 16 gauge 300 series polished stainless steel.

Crossbracing—1¼" (38mm)-diameter

- Heavy gauge, galvanized.
- Aluminum castings join crossbraces, legs and rear brace.

Legs—1½" (41mm)-diameter

- Tables 96" (2438mm) and longer come with six legs or more.
- Heavy gauge galvanized steel.
- 1" (25mm) adjustable hi-impact plastic feet*.

* Optional casters available. Consult factory.

Item No.: _____
Project No.: _____
S.I.S. No.: _____

Worktables with Backsplash and Galvanized Tubular Base —Deluxe Series

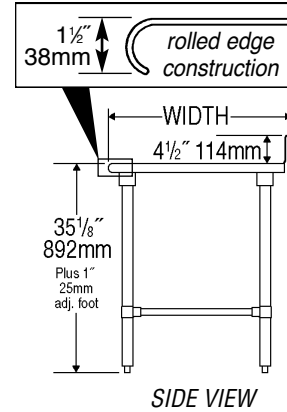
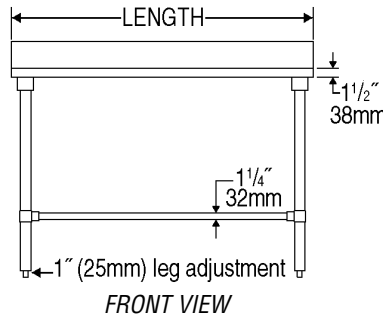
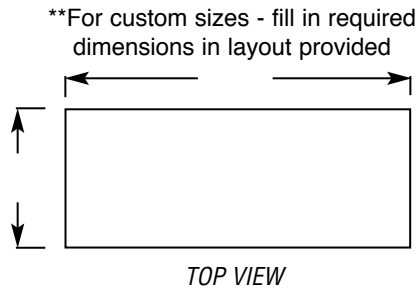

model #	# of legs	width		length		weight	
		in.	mm	in.	mm	lbs.	kg
BPT-2424GTEB-BS	4	24"	610	24"	610	41	18.6
BPT-2430GTEB-BS	4	24"	610	30"	762	46	20.9
BPT-2436GTEB-BS	4	24"	610	36"	914	51	23.1
BPT-2448GTEB-BS	4	24"	610	48"	1219	61	27.7
BPT-2460GTEB-BS	4	24"	610	60"	1524	71	32.2
BPT-2472GTEB-BS	4	24"	610	72"	1829	81	36.7
BPT-2484GTEB-BS	4	24"	610	84"	2134	91	41.3
BPT-2496GTEB-BS	6	24"	610	96"	2438	101	45.8
BPT-3024GTEB-BS	4	30"	762	24"	610	45	20.4
BPT-3030GTEB-BS	4	30"	762	30"	762	51	23.1
BPT-3036GTEB-BS	4	30"	762	36"	914	56	25.4
BPT-3048GTEB-BS	4	30"	762	48"	1219	66	29.9
BPT-3060GTEB-BS	4	30"	762	60"	1524	76	34.5
BPT-3072GTEB-BS	4	30"	762	72"	1829	86	39.0
BPT-3084GTEB-BS	4	30"	762	84"	2134	96	43.6
BPT-3096GTEB-BS	6	30"	762	96"	2438	106	48.1