



Project _____
 AIA # _____ SIS # _____
 Item # _____ Quantity _____ C.S.I. Section 114000



BLAST CHILLERS

TBC-SERIES
Undercounter Blast Chiller
Self-Contained



STANDARD PRODUCT FEATURES

- High Performance Refrigeration System
- Easy to Use Touch Screen Control with Automatic or Manual Operation
- Adjustable Product Target Temps (40° to -5°F) or Cycle Times
- Four Chill Settings: Blast Chill, Speed, Energy Saving & Delicate
- On-Board Cycle Data Printer
- Three (3) Removable Food Probes
- USB Port, 90-Day Cycle Data Memory
- Stainless Steel Exterior & Interior
- Heavy Gauge Stainless Steel Work Top
- Long Life E-Z Clean Door Gasket(s)
- Five (5) Universal Type Tray Slides (factory installed)
- Easy to Maintain Front Facing Condenser Coil
- 3-Year Parts & Labor Warranty
- 2-Years Additional Compressor Parts Warranty



This unit is listed to the applicable UL, CSA and NSF Standards by an approved NRTL. Consult the factory or unit's data plate for approval information.

ACCESSORIES & OPTIONS (*field installed)

- ▣ Label Printer (adds "-LP" to device number)
- ▣ Set of Four (4) 4-5/8" High Casters

AVAILABLE CONFIGURATIONS

Model	Hinging	Supports	Stainless Steel Back
TBC5-50	Right	6" Casters	No
TBC5-51	Left	6" Legs	No
TBC5-52	Right	6" Legs	No
TBC5-54	Right	6" Casters	Yes
TBC5-58	Left	6" Casters	Yes
TBC5-62	Left	6" Casters	No

Approved by _____ Date _____ Approved by _____ Date _____



MODEL

TBC5

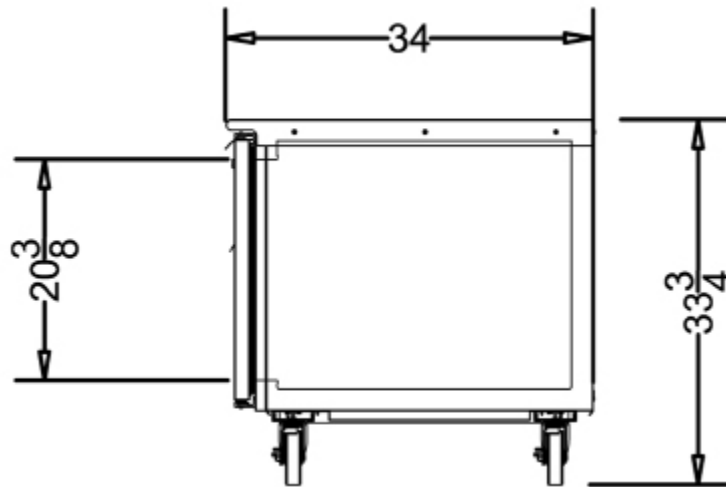
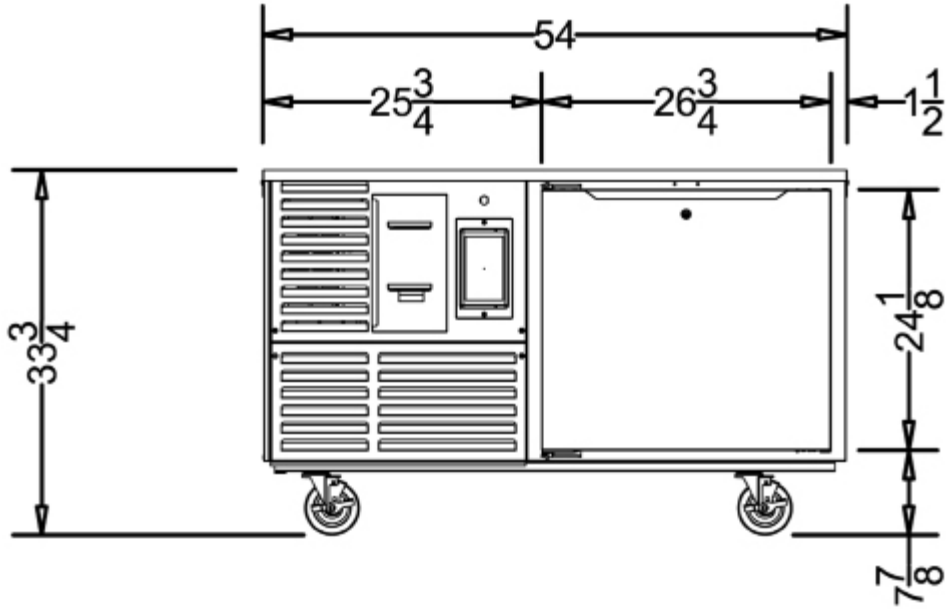

TBC-SERIES

Blast Chiller, Undercounter
Self-Contained Solid Door

MODEL
TBC5

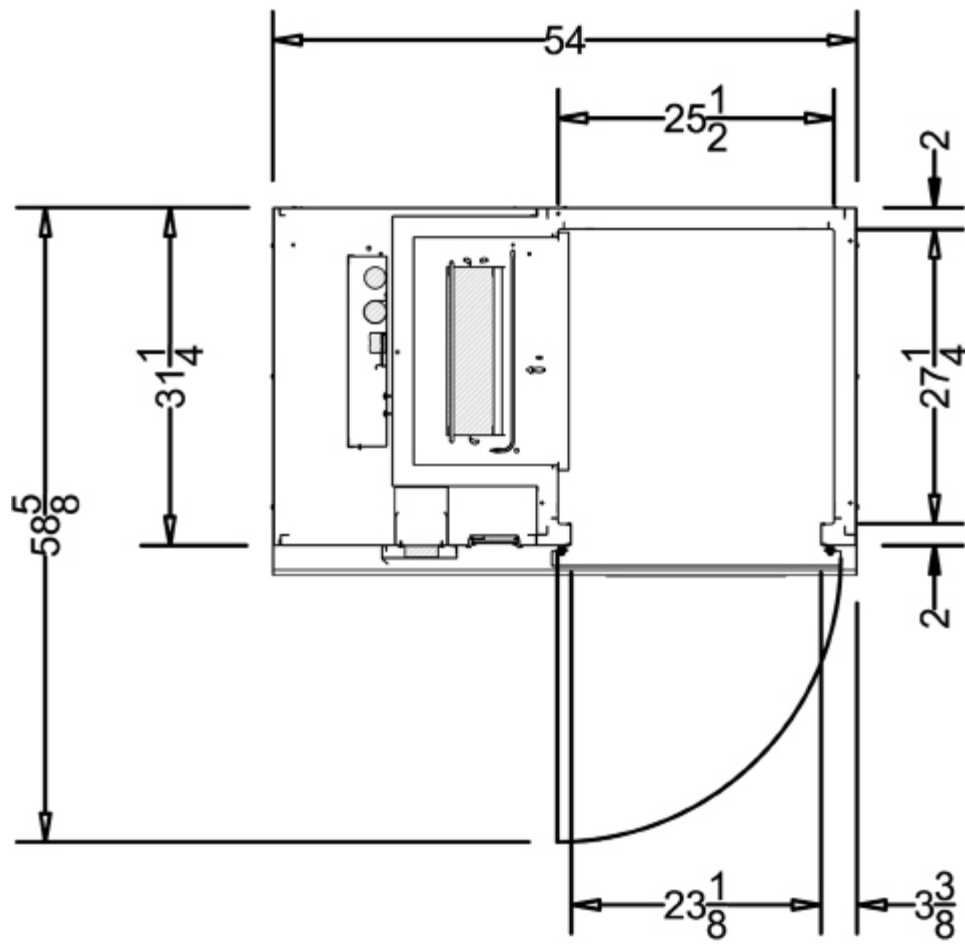



TBC-SERIES

Undercounter Blast Chiller

Self-Contained

MODEL

TBC5

MODELS	TBC5
DIMENSIONAL DATA	
Net Capacity cu. ft.	9.2 (267 l)
L x D x H - Overall in. ¹	54 (137.2 cm) x 34 ⁷ / ₈ (88.8 cm) x 33 ³ / ₄ (85.7 cm)
Depth - over body in.	34 (86.4 cm)
Depth - door open 90° in.	58 ⁵ / ₈ (148.9 cm)
Clear door W x H in.	23 ³ / ₈ (58.7 cm) x 20 ³ / ₈ (69.9 cm)
No. Tray Slides	5
Pan Capacity	(5) 18" x 26" (10) 12" x 20"
Product Capacity lbs.	100
ELECTRICAL DATA	
Voltage Plug	115/60/1 NEMA 5-20P (attached)
Feed wires with ground	3
Full Load Amps Req'd Circuit	16.0 20 Amp
REFRIGERATION DATA	
Refrigerant	R-448A
Refrigerant Charge Amt. oz	24 (680. 4 gr)
BTU/HR H.P. ²	4400 3/4 HP
Required Clearance	n/a
SHIPPING DATA	
L x D x H Crated in.	66(167.6 cm) x 42 (106.6 cm) x 40 (101.6 cm)
Volume Crated cu. ft.	65 (1840.6 l)
Uncrated Crated Weight lbs.	713 (323.4 kg) 653 (296.1 kg)

NOTES:

1. Height shown when mounted on standard 6" high legs or casters.
2. Based on a 90°F ambient and 0°F evaporator.

ESTIMATED PERFORMANCE CHART

TBC5 Product Load	Chill Time From 135°F to 40°F
50 (lbs.)	85
75 (lbs.)	140
100 (lbs.)	180

EQUIPMENT SPECIFICATIONS

CONSTRUCTION, HARDWARE, INSULATION

Cabinet exterior and interior are constructed of stainless steel. The exterior cabinet back and bottom are constructed of heavy gauge galvanized steel. A heavy gauge stainless steel bull-nose work top is provided standard. Door is equipped with a cylinder lock and guaranteed for life self-closing cam-lift hinges with a stay open feature at 120 degrees. Gasket profile and durable long life material simplify cleaning and increase overall gasket life. Anti condensate heaters are located behind the door opening. Both the cabinet and door are insulated with an average of 2" thick high density, non-CFC, 100% foamed in place polyurethane.

SELF-CONTAINED REFRIGERATION SYSTEM

A high-capacity, self-contained refrigeration system using environmentally friendly, non flammable R-448A refrigerant is coupled with an advanced air circulation system to rapidly chill hot food through the HACCP danger zone. It features a thermostatic expansion valve, high-humidity evaporator coil, high speed evaporator fan, air-cooled hermetic compressor, hot gas defrost and a non-electric condensate evaporator. The condenser coil is front facing for easy cleaning. Defrost occurs automatically, does not interrupt chill cycles in progress, nor starting new chill cycles, and intervals between defrost cycles are adjustable to better suit differing operational needs. A 9' cord and plug is provided.

CONTROL / BASIC OPERATION

The easy to use touch screen control is water resistant and protected from damage by a heavy gauge stainless steel bezel. Using the three probes provided, it monitors cycle progress and records all HACCP required data. This information can then be printed at the end of the cycle using the on-board printer and/or retrieved later from memory, where it is stored for 90-days.

Chill cycles can be started in one of two ways using either the AUTO (touch free) or MANUAL (fully adjustable) operating mode. In AUTO mode, placing any probe in 90°F or above product will initiate a chill cycle using the default parameters (standard blast chill with a target temperature of 37°F) in approximately 30-seconds. In MANUAL mode, the operator can adjust all the cycle parameters to suit their needs. Upon pressing START the chill cycle will commence using these inputs. Failure to complete cycle programming in MANUAL mode will result in the chill cycle starting automatically in 5-minutes after the last button push (provided at least one probe had been placed in product 90°F or above).

Product and/or user names can be manually input at the beginning or end of the chill cycle if desired. Customized chill cycle parameters (i.e. chill recipes) can be loaded and stored in advance, by name.

Once a chill cycle is started, it will continue without interruption until either the target temperature (using probes) or time (without using probes) is met. When using the default target temperature of 37°F, rapidly circulating air will cycle between 10-14°F or as low as -25°F when the target temperature is set at -5°.

Upon cycle completion, the blast chiller will notify the operator with an audible alarm, and automatically revert to maintenance mode, holding the product at the target temperature until removed.

INTERIOR ARRANGEMENTS

Standard interior arrangements include five (5) adjustable universal type tray slides, installed at the factory.

DOMESTIC WARRANTY

Both a three year parts and labor warranty and an additional two year compressor parts warranty (for a total of five) are provided standard.

CONTINUED PRODUCT DEVELOPMENT MAY NECESSITATE SPECIFICATION CHANGES WITHOUT NOTICE.