



Project \_\_\_\_\_  
 AIA # \_\_\_\_\_ SIS # \_\_\_\_\_  
 Item # \_\_\_\_\_ Quantity \_\_\_\_\_ C.S.I. Section 114000

## TB SERIES

### Full Size Glycol Prep Table Self Contained 91" Two & Three Row Pan Models



### STANDARD PRODUCT FEATURES

- Glycol System Exceeds NSF7 Requirements by Maintaining Food at or Below 39°F Using Specified 8" Deep Pans
- Stainless Steel Exterior & Interior
- Reliable Microprocessor Control with LED Temperature Display
- Heat Exchanger and Pump Closely Located from and in Communication with Refrigeration Controls
- Horizontal Finned T6 Anodized Chiller Plates, Holds 1/3, 1/6, or 1/9 Size Pans Up to 8" Deep (pans supplied by others)
- General Fit 7.6" Chiller Bar Spacing
- Sloped Rail
- 14" White Poly Cutting Board (2 row pan rail models)
- 8" White Poly Cutting Board (3 row pan rail models)
- 20" Stainless Steel Door
- Standard Hinging: Left/Right/Right (other hings available)
- Self-Closing Door(s) with Stay-Open Feature at 120 Degrees
- Metal Door Handle(s) with Gasket Guard
- Magnetic Snap-In Door Gasket(s)
- Two (2) Powder Coated Shelves Per Door (factory installed)
- Stainless Steel Lift-Off Night Cover
- Thermostatic Expansion Valve Metering Device
- 9' Cord & Plug Attached
- Set of Four (4) 6" High Casters



This unit is listed to the applicable UL, CSA and NSF Standards by an approved NRTL. Consult the factory or unit's data plate for approval information.

### AVAILABLE CONFIGURATIONS

46", 60", 65", 71", 91" & 113" Wide Models

#### 2 Row Pan Rail

91" Long Model for 12 x 1/6 Pans **Model** TB091SL2S

#### 3 Row Pan Rail

91" Long Model for 18 x 1/6 Pans **Model** TB091SL3S

### ACCESSORIES & OPTIONS

- Drawers in Lieu of Door(s)
- Trayslides
- Stainless Steel Finished Back
- Set of Four (4) 4" High Casters in Lieu of Standard Casters
- Set of Four (4) 6" High Legs in Lieu of Standard Casters
- Full Length Removable Composite (richlite brown) Cutting Board
- Hinged Night Cover (2 row pan rail models only)
- Stainless Steel Single or Double Overshelf

Approved by \_\_\_\_\_ Date \_\_\_\_\_ Approved by \_\_\_\_\_ Date \_\_\_\_\_

**MODELS**

91" Long Models: TB091SL2S, TB091SL3S

**2 Row Pan Rail Model**

**Plan View**

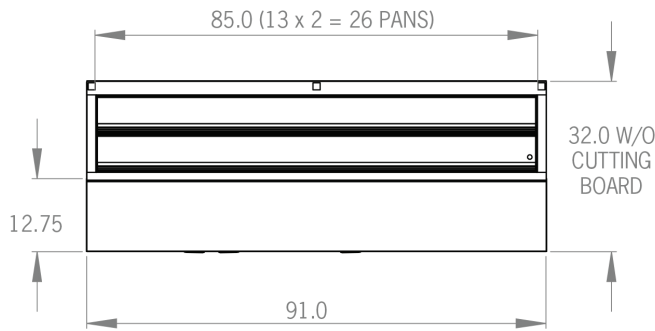

**Isometric View**

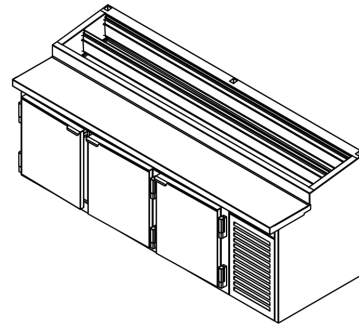

**Section View**

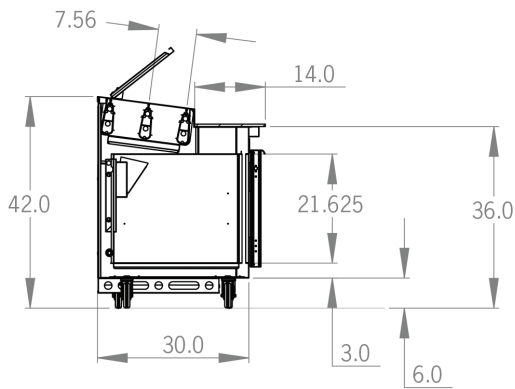

**Elevation View**

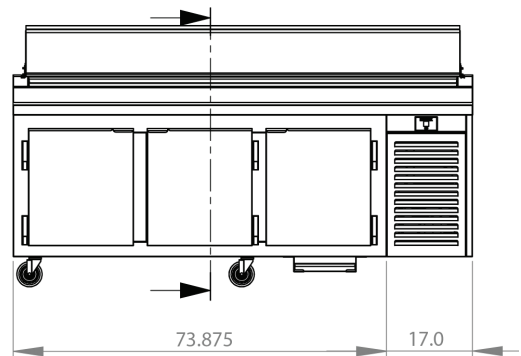

**3 Row Pan Rail Model**

**Section View**

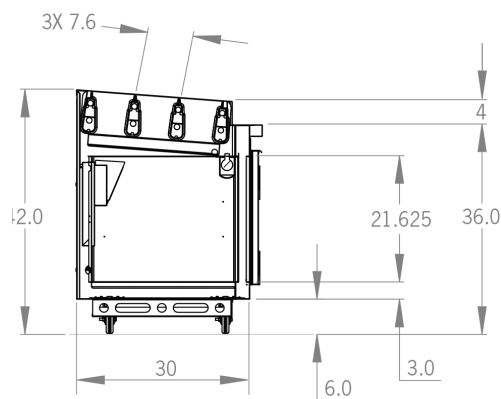

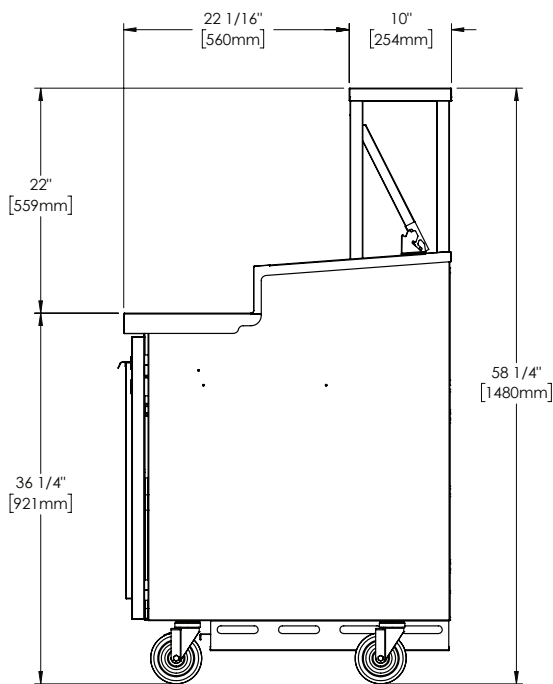

TB Single Over Shelf  
**\*OPTIONAL ACCESSORY**

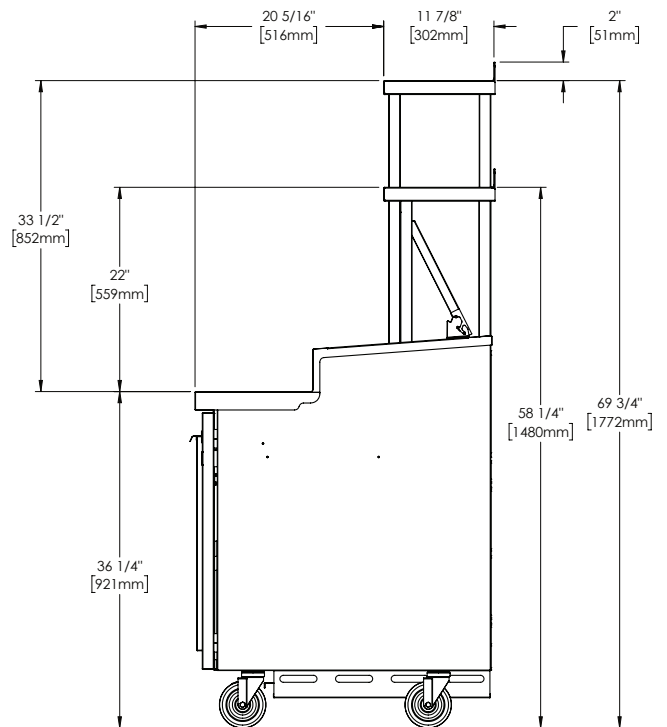

TB Double Over Shelf  
**\*OPTIONAL ACCESSORY**



# TB SERIES

Full Size Glycol Prep Table Self Contained  
91" Two & Three Row Pan Models

## MODELS

91" Long Models: TB091SL2S, TB091SL3S

MODELS	TB091SL2S	TB091SL3S
<b>DIMENSIONAL DATA</b>		
Net Capacity cu. ft	23.4 (662.6 l)	23.4 (662.6 l)
Length - Overall in.	91 (231.1 cm)	91 (231.1 cm)
Depth - Overall in.	33.5 (85.1 cm) <sup>1</sup>	35 (88.9 cm) <sup>2</sup>
Height - Overall in. <sup>3</sup>	42 (106.7 cm)	42 (106.7 cm)
Height with Lid Open in. <sup>4</sup>	50 (127 cm)	50 (127 cm)
Clear Door Width in.	18.5 (47 cm)	18.5 (47 cm)
Clear Door Height in.	21 (53.3 cm)	21 (53.3 cm)
No. of Doors	3	3
Standard Door Hinging	LH/RH/RH	LH/RH/RH
No. of Standard Shelves	6	6
Work Surface Height in.	36 (91.4 cm)	36 (91.4 cm)
No. of 1/6 Size Pans	26	39
Weight lbs.	940 (426.4 kg)	940 (426.4 kg)
<b>ELECTRICAL DATA</b>		
Voltage	115/60/1	115/60/1
Plug (attached)	NEMA 5-15P	NEMA 5-20P
Full Load Amperes	10	12
<b>REFRIGERATION DATA<sup>4</sup></b>		
Refrigerant	R-450A	R-450A
Refrigerant Amount oz.	16.5 (467.8 gr)	12 (340.2 gr)
BTU/HR - HP <sup>5</sup>	4100   1/2	6320   3/4

Figures in parentheses reflect metric equivalents.

### NOTES:

- Overall depth with standard 14" cutting board.
- Overall depth with standard 8" cutting board. Optional 10" cutting board = 37" overall depth. Optional 14" cutting board = 41" overall depth.
- Height shown when mounted on standard 6" high casters.
- Height shown when mounted on standard 6" high casters and the lid in fully open position.
- Based on a 90°F ambient and 20°F evaporator.



2 Row Pan Rail models equipped with one NEMA 5-15P Plug



3 Row Pan Rail models equipped with one NEMA 5-20P Plug

Full load amps and plug style may vary depending on electrical options chosen and condensing unit employed.

When ordering please specify voltage, hinging, and optional accessories.

## EQUIPMENT SPECIFICATIONS

### CONSTRUCTION, HARDWARE, INSULATION

Unit exterior front, top and sides are constructed of stainless steel, exterior back and bottom are constructed of galvanized steel. Cabinet interior is constructed of stainless steel. A set of 6" high casters are provided standard.

The stainless steel 4" high raised ingredient rail is slightly sloped toward the operator with a glycol pan chiller system composed of anodized aluminum horizontal chiller plates to accommodate 1/3, 1/6 and 1/9 size pans up to 8" deep. Stainless steel lift-off night cover is included standard.

Door(s) are equipped with guaranteed for life self-closing cam-lift hinges with a stay-open feature at 120 degrees. A metal door handle with gasket guard is standard on all units.

The cabinet is insulated with an average of 2" thick high density, non-CFC, foamed in place polyurethane.

### SELF-CONTAINED REFRIGERATION SYSTEM

The self-contained refrigeration system cools the cabinet interior, as well as the raised ingredient rail through use of propylene glycol chiller plates, creating proximity cooling around the pans. This patented rail system keeps pans cold without freezing product and allows for "all-day" temperature performance to NSF7 test requirements. The condensing unit utilizes a hermetically sealed compressor, glycol pump, glycol heat exchanger, and glycol expansion tank, with most components easily accessible behind louver panel. A 9' cord and plug is supplied standard. Standard base operating temperature is 34°F to 38°F (1.1 °C to 3.3°C).

### CONTROL

The easy to use water resistant microprocessor control system is supplied standard. It includes a 3-Digit LED Display, and a Fahrenheit or Celsius Temperature Scale Display Capability.

### INTERIOR ARRANGEMENTS

Standard interior arrangements include two (2) powder coated wire shelves per door, mounted on shelf pins. Recommended load limit per shelf should not exceed 225 lbs. Optional tray slides may be purchased in combination with, or in lieu of these. Both standard and optional interior arrangements are completely installed at the factory.

### WARRANTY

Both a six year parts and labor warranty and a seven year compressor warranty (self-contained models only) are provided standard.

### RECOMMENDED PAN BRANDS FOR STANDARD PAN CHILLER FIT AND SPACING

BRAND	ITEM DESCRIPTION
Cambro	Polypropylene
Cambro	Polycarbonate
Carlisle	Polycarbonate
Carlisle	Stainless Steel
Syscoware/Vollrath	SPI
Syscoware/Vollrath	SPIII
Rubbermaid	Polycarbonate
JR	S/S
Crestware	S/S