

Non-Refrigerated Self-Service Case

- NR3647DSSV
- NR4847DSSV

Lengths include end panels
 35-3/4"L x 33"D x 47-1/8"H
 47-3/4"L x 33"D x 47-1/8"H



STANDARD FEATURES

- NOTE: Glass warranty only applicable to first point of delivery
- (2) Levels of clear glass shelving removable and adjustable on 1" centers
- LED top & shelf lights
- One piece formed ABS plastic tub
- One year parts & labor warranty

Features	Standard	Options
EXTERIOR COLOR	<input type="checkbox"/> Black	<input type="checkbox"/> Painted (non-stock colors, specify RAL#) <input type="checkbox"/> Painted (stock colors, specify RAL#) <input type="checkbox"/> Stainless steel
INTERIOR COLOR	<input type="checkbox"/> Black	<input type="checkbox"/> NOTE: Interior color must be FDA & NSF approved <input type="checkbox"/> Painted (stock colors, specify RAL#) <input type="checkbox"/> Stainless steel
PANEL EXTERIOR	<input type="checkbox"/> Laminated (non-premium) Confirm pattern/grain direction	<input type="checkbox"/> Laminated (premium) Confirm pattern/grain direction <input type="checkbox"/> Stainless steel
BASE SUPPORT	<input type="checkbox"/> Adjustable, locking casters (n/a w/ remote ref.)	<input type="checkbox"/> 6"H stainless steel legs
END PANEL LEFT	<input type="checkbox"/> Full end panel	<input type="checkbox"/> No end panel
END PANEL RIGHT	<input type="checkbox"/> Full end panel	<input type="checkbox"/> No end panel
LOWER FRONT PANEL	<input type="checkbox"/> Black	<input type="checkbox"/> Painted (stock colors, specify RAL#) <input type="checkbox"/> Stainless steel
LOWER REAR PANEL	<input type="checkbox"/> Black	<input type="checkbox"/> Painted (stock colors, specify RAL#) <input type="checkbox"/> Stainless steel
UPPER REAR	<input type="checkbox"/> Solid back panel	<input type="checkbox"/> Clear glass rear sliding doors <input type="checkbox"/> Reflective glass rear sliding doors
LIGHTS	<input type="checkbox"/> LED 3500K w/ frosted lens	<input type="checkbox"/> LED 3000K w/ frosted lens <input type="checkbox"/> LED 4000K w/ frosted lens
ELECTRICAL CONNECT	<input type="checkbox"/> 12" straight blade power cord	<input type="checkbox"/> 12" locking power cord <input type="checkbox"/> Electrical leads (non-refrigerated)
MISCELLANEOUS		<input checked="" type="checkbox"/> 14.5" Base height extension <input type="checkbox"/> Rear door lock <input type="checkbox"/> Second year parts & labor warranty
ACCESSORIES		<input type="checkbox"/> Clear acrylic security cover, removable, locking

Option Notes: 1 - Cannot be combined w/ 6"H legs

Reveal®

Product Specifications

Intended Environment: Type I - Designed to operate in ambient conditions of 75°F with 55% relative humidity unless noted otherwise in system information below.		
Zone	Intended Product To Be Displayed	Warmest Avg Prod Temp ° F
1	Packaged non-refrigerated products	Ambient

PLAN VIEW

SIDE VIEW

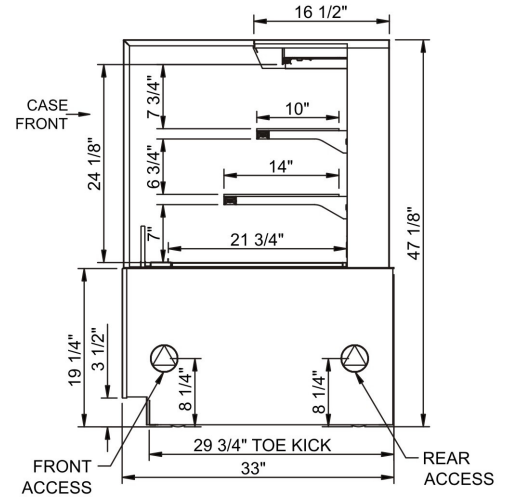
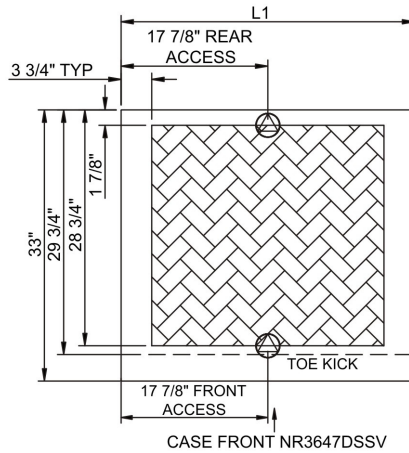
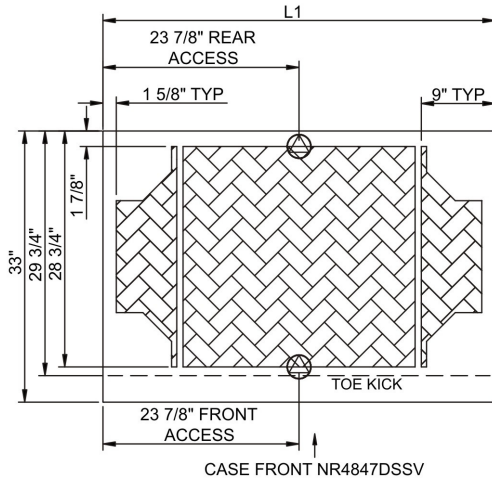

NOTE: ALL DIMENSIONS APPROXIMATE

- ELECTRICAL JUNCTION BOX (SUPPLIED WITH 6" LEADS OR POWER CORD).
- LOCATION OF DRAIN TUBE FOR REMOTE REF. ONLY (SUPPLIED WITH 3/4" OR 1 1/2" PVC TUBE).

- REFRIGERATION LINE CONNECTION.
- REMOTE FLOOR SINK & UTILITIES ACCESS AREA.

- SELF-CONTAINED CASE SERVICE ACCESS AREA.
- DRY CASE SERVICE ACCESS AREA.

Model Technical Specifications																
Model	L"	L1"	L2"		System Circuit Volts	Phs	Freq	Amps ***	Watts	Wires	NEMA Plug	SST	Conv. Rack BTUH	Para. Rack BTUH	Est Wt	
NR3647DSSV	N/A	35.75	.00	Ambient/Lights	Circuit #1	110-120	1	60	0.70	11	2+G	5-15P or L5-15P	N/A	N/A	N/A	600
NR4847DSSV	N/A	47.75	.00	Ambient/Lights	Circuit #1	110-120	1	60	0.70	17	2+G	5-15P or L5-15P	N/A	N/A	N/A	700

*** Does not include electric defrost on freezer models.

Important Notes:

- 1) ELECTRICAL NOTE: If GFCI is required, a GFCI breaker MUST be used in lieu of a GFCI receptacle
- 2) Glass warranty only applicable to first point of delivery.

⚠ WARNING: This product can expose you to chemicals, including Urethane (Ethyl Carbamate), which are known to the State of California to cause cancer and birth defects or other reproductive harm. For more information go to www.P65Warnings.ca.gov.

Regulatory Approvals:	
All Models	ETL Listed to UL 65 ETL Sanitation to NSF 2

