

Project:



Scan for more info!

Owners manual
Quick install
Quick sizing
Install layout
Parts list

CR-2SW Countertop



Chilled water on tap

- High capacity chiller for ice cold water
- Flow control faucets for chilled still water on 2 valves
- Faucet clearance for filling 12" tall bottles
- Mirrored finish stainless steel exterior
- Made in the USA

Specifications

- 68 liters/18 gal per hour @40°
- Self-contained refrigeration system
- Compressor: 1/3 H.P.
- Refrigerant: R134a CFC-free
- BTU: 2,400 per hour Ave
- Operating temperature range: 40° - 100°
- Electrical: 120v - 15 Amps
- Water Bath: 6 Gallons
- Ice Bank: 25 lbs
- Weight: 135 lbs
- Clearance: 12"
- 20"W x 28"D x 24.75"H

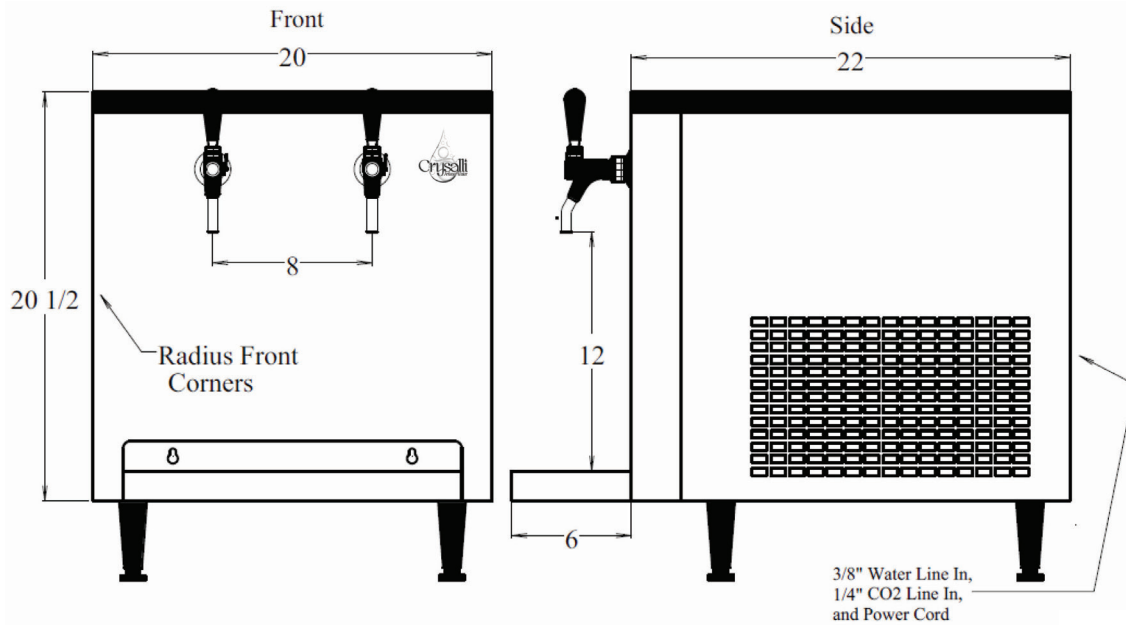

- 3/8" Water inlet connector
- 7' Over flow drain hose
- 9' Electrical cord NEMA 5-15
- 4.25" legs
- Air intake at rear with air filter
- Allow for 6" rear & side clearance around unit for air flow

Accessories:

- CR-24FCP with prefilter
 - CR-24FC without prefilter
- Twin filter system with compact fibredyne filters, 19"H x 17"W 5 gpm, 30,000 gal, TOC & 1/2 micron filtration



- CR-KIT-SWCT
- Installation kit for countertop still water chillers, CR-1SW & CR-2SW, includes: Various fittings and oetiker clamps, and extra tubing
Still Water units only



- CR-SDL-SSX1
- Universal sanitary lever assembly for use on countertops, custom towers, and are able to be retrofit to CBR towers

