



Project _____

Item # _____

Quantity _____

Drop-In Induction Dry Well

Model: IWELB-FUL-A

Hatco's Drop-In Induction Dry Well features a simple, robust design and offers an energy efficient, plumbing-free solution to maintain food at the right temperatures for safety and quality. This unit is adjustable with little effort and can hold either a 2.5" or 4" (64 or 102 mm) deep, full-size pan. The well evenly and consistently heats the pan to keep foods hot and fresh.

Standard features

- Durable and tough glass-ceramic well bottom can be easily adjusted to accommodate a 2.5" or 4" (64 or 102 mm) deep pan
- Made for use with an unlimited combination of normal, full-size, half-size, third-size and quarter-size stainless steel pans
- Contains two heat zones with two temperature probes in each zone
- An easy-to-use, mountable control panel that can adjust heating temperatures in Fahrenheit, Celsius or by five preset temperature levels between 150° and 210°F (66° and 99°C)
- Features a sensor that prohibits the unit to turn on unless a pan is present
- Includes a single stainless steel bezel and two support bars
- Can be top or bottom mounted into a countertop

IWELB-FUL-A shown with 2.5" (64 mm) deep pan

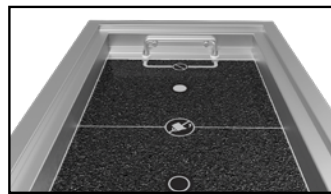

IWELB-FUL-A adjusted for a 2.5" (64 mm) deep pan

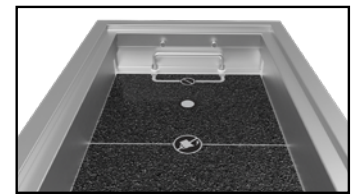

IWELB-FUL-A adjusted for a 4" (102 mm) deep pan

Accessories

- Rectangular Full-Size Stainless Steel Food Pans:
- Third-Size (2.5" [64 mm] H) Half-Size (2.5" [64 mm] H)
 - Full-Size (2.5" [64 mm] H) Full-Size (4" [101 mm] H)
- Bezels for grouping multiple units:
- IWELBEZEL-2 IWELBEZEL-3
- Stainless Steel Wire Trivets: Half-Size Full-Size

For operation, location and safety information, please refer to the Installation and Operating Manual.



HATCO CORPORATION | P.O. Box 340500 Milwaukee, WI 53234-0500 U.S.A. | (414) 671-6350



www.hatcocorp.com | support@hatcocorp.com | [Find a Hatco Rep](#) | [Image Library](#) | [Document Library](#) | [Patents](#) | [Chat](#)



Drop-In Induction Dry Well

Models: IWELB-FUL-A

IWELB-FUL-A Model

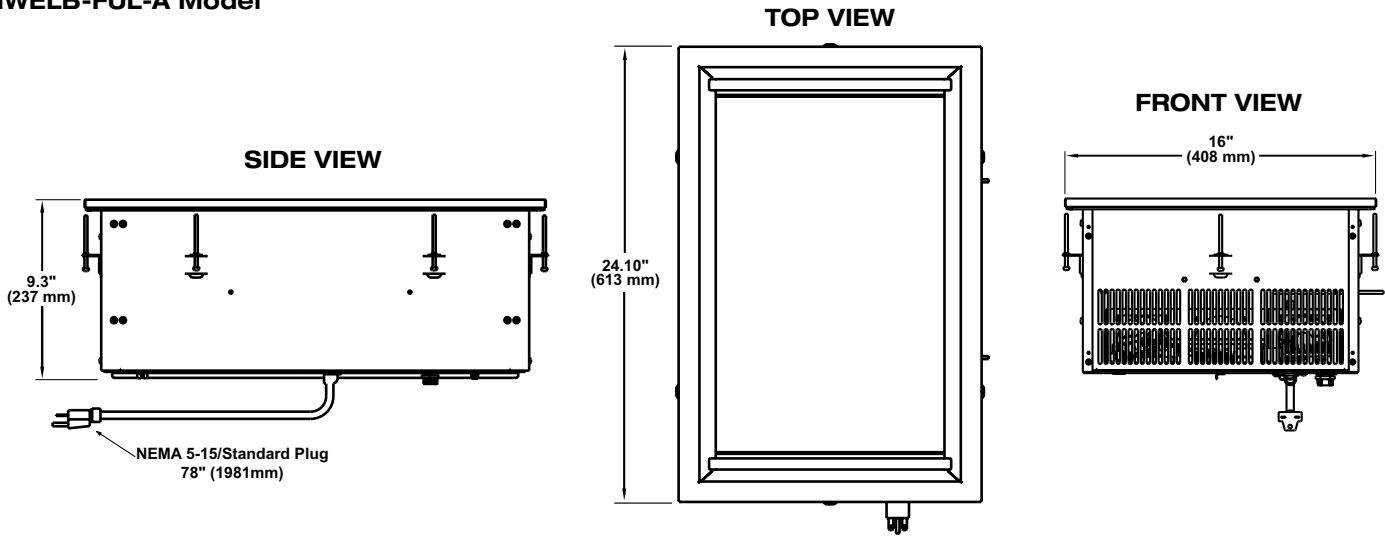

SPECIFICATIONS Drop-In Induction Dry Well

Models	Dimensions (W x D x H)	Voltage	Watts	Amps	Hz	Cord	Shipping Weight
IWELB-FUL-A	24.10" x 16" x 9.3" (613 x 408 x 237 mm)	120	720	6.7	50-60	NEMA 5-15P	43 lbs. (20 kg)
		208		4.3		NEMA 6-15P	
		240		3.9		CEE 7/7, BS-1363, AS 3112, CH1-10P	
		220-230-240		4.1-4.0-3.9			

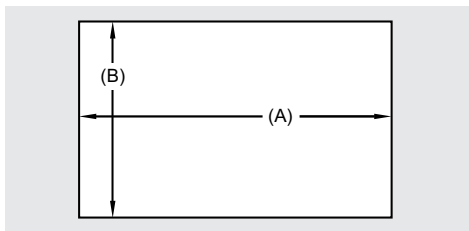

Cutout Dimensions for Countertops

Model	Width (A)	Depth (B)
IWELB-FUL-A	22.875" (580 mm)	14.875" (377 mm)

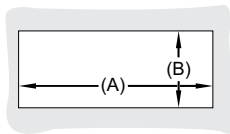

Cutout Dimensions for Control Panel

Model	Width (A)	Height (B)
IWELB-FUL-A	5.5" (139 mm)	2.188" (55 mm)

PLUG CONFIGURATIONS

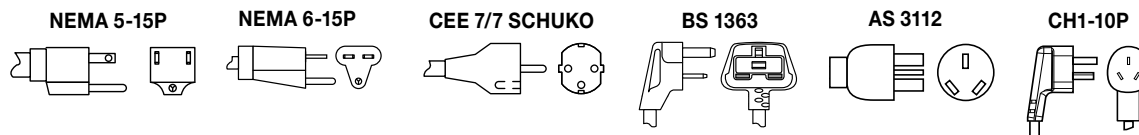

PRODUCT SPECS Drop-In Induction Dry Well

The Drop-In Induction Dry Well shall be manufactured by the Hatco Corporation, Milwaukee, WI 53234 U.S.A.

The Drop-In Induction Dry Well shall be rated at 720 watts, 120, 208-240 volts, single phase and be ... inches (millimeters) in overall width. The Drop-In Induction Well shall consist of a housing with an aluminum base with a dual generator coils and a glass-ceramic well bottom. It includes a remote control panel and temperature control in five

power levels, F° or C°. Features a USB port for updates and future access to additional operating modes. Two food temperature probes per heating zone and 71" (1800 mm) cord and plug is included.

Warranty consists of 24/7 parts and service assistance (US and Canada only).

HATCO CORPORATION

P.O. Box 340500 Milwaukee, WI 53234-0500 U.S.A. | (414) 671-6350



www.hatcocorp.com

support@hatcocorp.com

[Find a Hatco Rep](#)

[Image Library](#)

[Document Library](#)

[Patents](#)

[Chat](#)