



PROJECT

ITEM NO:

QUANTITY:

Clean Dish Tables

Straight Design

FEATURES & CONSTRUCTION:

- Top is fabricated with 1-1/2" rounded edge on all working sides and 10-1/2" high backsplash.
- Table front edges formed with hemmed edges to provide extra rigidity and safe to touch finished.
- Reinforced table top with sound deadening hat channels.
- All exposed welded areas smooth polished to brush finish sanitary #4.
- Stainless steel legs with welded cross brace.
- Welded stainless steel leg socket for removable "H" style table legs.
- All units shipped K.D. but easily assembled.



NSF STD.2
Certified



Left Side



Right Side

MATERIAL:

- Top: 16 Ga. Stainless Steel - 304
 Leg: 16 Ga. Stainless Steel
 (1-5/8" Tubing)
 Leg Bracing: 20 Ga. Stainless Steel -201
 (1-1/4" Tubing)
 Leg Socket: Stainless Steel
 Bullet Feet: Stainless Steel (1" Adjustable)

Clean Dish Tables

L	Left Side	Right Side
	MODEL NO.	
24"	SMCDT-24L	SMCDT-24R
30"	SMCDT-30L	SMCDT-30R
36"	SMCDT-36L	SMCDT-36R
48"	SMCDT-48L	SMCDT-48R
60"	SMCDT-60L	SMCDT-60R
72"	SMCDT-72L	SMCDT-72R
84"	SMCDT-84L	SMCDT-84R
96"		SMCDT-96R

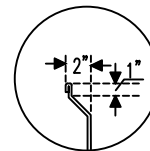

45° Slanted Backsplash
Reinforced With
Hemmed Edge

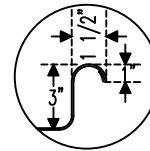

Rolled Rim Edge
Front And Rear
Reinforced with
Hemmed Edge

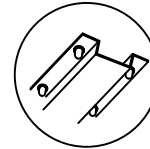

Top Reinforced
with Hat Channels



Stainless Steel
Bullet Feet
1" Adjustable



Rev. 10/20

SAPPHIRE MANUFACTURING
Tel: 718-543-2111
Fax: 718-543-2121

info@sapphiremanufacturing.com
WWW.SAPPHIREMANUFACTURING.COM



PROJECT

ITEM NO:

QUANTITY:

Clean Dish Tables

Straight Design



NSF STD.2
Certified

Left Side

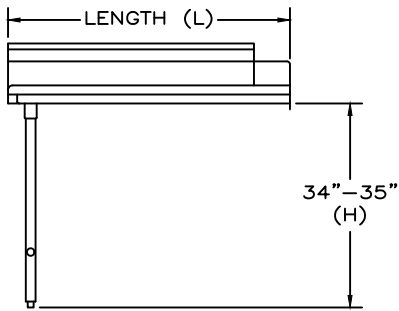
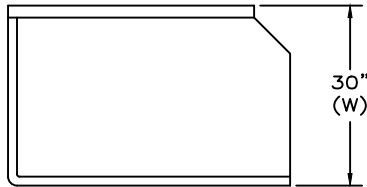

Right Side

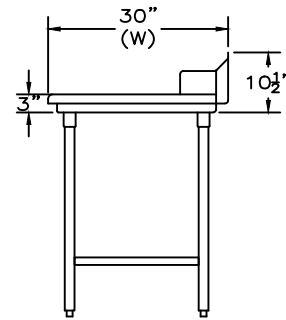
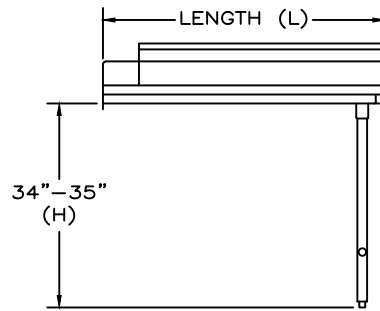
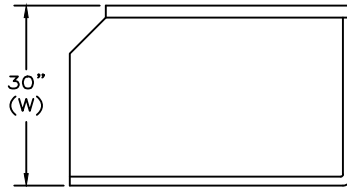

Common End View

Left Side

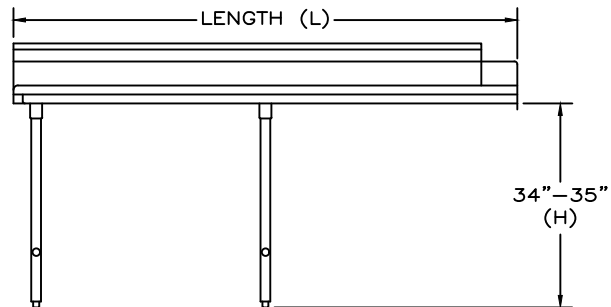
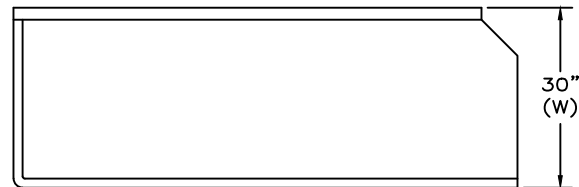

Right Side

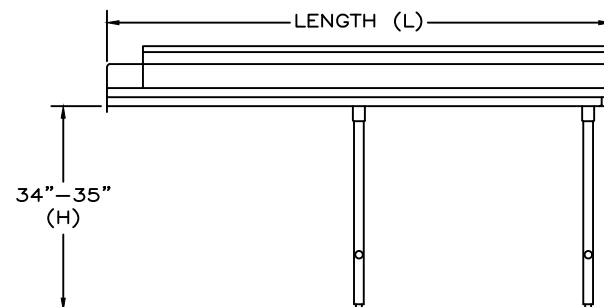
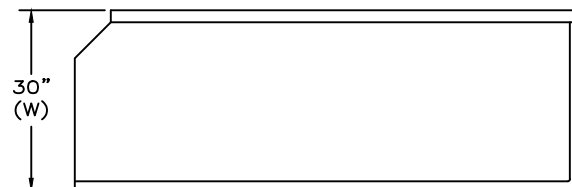

* 84" tables and longer come with 4 legs

Specifications subject to change without notice.

All dimensions are typical (Tolerance 1/2").



Rev. 10/20

SAPPHIRE MANUFACTURING
Tel: 718-543-2111
Fax: 718-543-2121

info@sapphiremanufacturing.com
WWW.SAPPHIREMANUFACTURING.COM