



# BEVERAGE-AIR®

Project: _____	AIA#
Item: _____	SIS#
Location: _____	
Approved: _____	

**DPD93HC FOOD PREPARATION : DELI/PIZZA PREP SERIES**

## FOOD PREPARATION TABLES

### DPD93HC Deli/Pizza Prep Table with Two Door and Two Drawers Hydrocarbon Series

**MODEL:**  
DPD93HC-2



**3 Year Parts/Labor Warranty**  
**Additional 4 Year Compressor Warranty**

#### CABINET CONSTRUCTION

- Stainless steel front, sides, top, doors, drawers and grille (galvanized back & bottom)
- Interior liner is made of corrosion resistant aluminum
- Aluminum top interior liner prevents spill from falling into cabinet
- Stainless steel top
- Removable hoods and insulated lid assemblies are made of matching stainless steel
- Self-closing doors with 120° stay-open feature on cam-lift hinges
- Magnetic gaskets provide positive seal on both door and drawers
- Field reversible doors
- 3" Casters, 2 with brakes standard
- 19" Wide reversible cutting board is removable for easy cleaning
- Four (4) epoxy-coated steel wire shelves
- Units will accept pans up to 6" deep (pans are not included)
- Drawer frames are heavy-duty stainless steel
- 12-Gauge stainless steel drawer slides with Delrin® rollers rated at 275 lbs
- Telescoping slides, with locking mechanism to prevent drawers from being pulled off of cabinet
- Heavy-duty pan locking divider supports are standard in drawers
- Compressor available on left or right, specify at time of unit order

#### OPTIONS & ACCESSORIES

- Stainless steel back
- Stainless steel interior
- Clear lid
- Overshelf kits
- Additional shelves
- Shelf clips
- Pan support
- Door locks
- Composite cutting board
- Thermometer
- Night cover
- Bun tray rack
- 6" Casters
- 6" Legs black or seismic/flanged
- Remote option\* (see note on back page)

#### REFRIGERATION SYSTEM

- Uses environmentally friendly, energy efficient R290 refrigerant, and meets all regulatory requirements for CARB, SNAP, DOE & more
- Adaptive defrost
- Epoxy coated evaporator coil
- Enhanced airflow maintains temperatures between 36° - 38°F



Please verify qualifying units by visiting:  
[www.energystar.gov/cfs](http://www.energystar.gov/cfs)

3779 Champion Blvd., Winston-Salem, NC 27105  
1-888-845-9800 Fax: 1-336-245-6453  
Beverage-Air.com Sales@bevair.com



# BEVERAGE-AIR

## Deli/Pizza Preparation Table with Drawers Model: DPD93HC-2

MODEL	DPD93HC-2
<b>EXTERNAL DIMENSIONAL DATA</b>	
Width Overall	93"
Depth Overall with Cutting Board	37"
Height Overall with Casters	53 1/8"
No. of Drawers	2
Depth with Drawer Extended	55 3/8"
Drawer Openings	21 5/8" x 10 3/4"
No. of Doors	2
Cutting Board	19"
<b>INTERNAL DIMENSIONAL DATA</b>	
NET Capacity (cubic ft.)	31.5
Internal Width Overall (in)	89"
Internal Width Usable (in)	74"
Internal Depth Overall (in)	26"
Internal Height Overall (in)	23 7/8"
No. of Shelves	4
<b>ELECTRICAL DATA</b>	
Full Load Amperes	7.8
<b>REFRIGERATION DATA</b>	
Horsepower	1/2
Capacity (BTU/Hr)	4234
Heat Rejection (BTU/Hr)	6351
Charge (lbs/grams)	0.264/120
<b>SHIPPING DATA</b>	
Gross Weight - Crated	632 lbs
Height - Crated	46"
Width - Crated	96"
Depth - Crated	36"

\*NOTE: Remote units are field wired and come with 6" legs.  
Refrigerant must be specified at time of order.

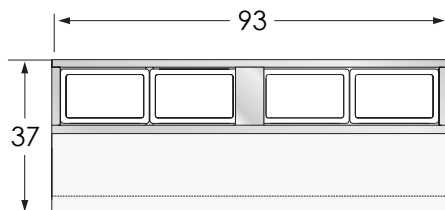

Top Configuration

### Model Views

Required Clearance: Rear 2"

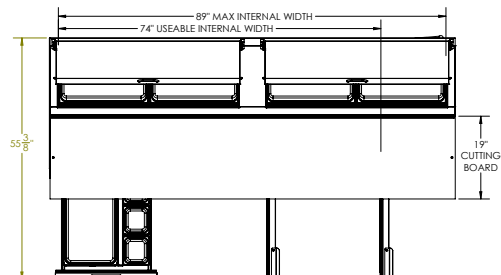

### PLAN VIEW

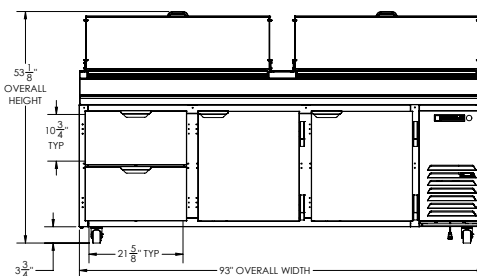

### ELEVATION VIEW

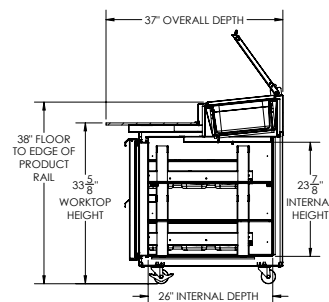

### SIDE VIEW



### ELECTRICAL CONNECTION



115/60/1  
NEMA 5-15P

Unit pre-wired at factory  
and include 8' long cord  
and plug set.