



**John
BOOS**
Since 1887

ITEM #: _____ QTY: _____
 MODEL #: _____
 PROJECT NAME: _____

061621

3601 S. Banker St. Effingham, IL 62401 • Ph: (888) 431-2667 • Fax: (800) 433-2667

"UBDS-21" UNDERBAR DUMP SINK **21" WIDTH**



STANDARD FEATURES:

- ALL 18 GAUGE STAINLESS STEEL CONSTRUCTION
- TYPE 300 STAINLESS STEEL WITH #4 POLISH, SATIN FINISH
- STANDARD PRE-DRILLED HOLES ON SIDES FOR ATTACHING ADJACENT UNITS TOGETHER
- REMOVABLE FAUCET PLATE WITH 4" ON-CENTER SPLASH MOUNT FAUCET HOLES
- PERFORATED DUMP BASKET 9-1/2" X 6" X 5" DEEP
- STANDARD FRONT INSERTS FOR BLENDER STATION SHELF ATTACHMENT
- STAINLESS STEEL FRONT TO BACK BRACING

SPECIFICATIONS:

- MATERIALS
 - TOP: 18 GAUGE TYPE 300 STAINLESS STEEL
 - FRONT APRON: 18 GAUGE TYPE 300 STAINLESS STEEL
 - BACKSPLASH: 18 GAUGE TYPE 300 STAINLESS STEEL
 - SIDES: 18 GAUGE TYPE 300 STAINLESS STEEL
- SINK BOWL
 - FABRICATED SINK BOWL: 14" X 10" X 10" DEEP
- LEGS AND BRACING
 - BOLT ON 1-5/8" STAINLESS STEEL LEGS FOR FAST INSTALLATION
 - 1-1/4" FRONT TO BACK BRACING
 - 1" ADJUSTABLE STAINLESS STEEL BULLET FEET
- MOUNTING OPTIONS
 - Z-CLIP TO MOUNT TO WALL
 - BOLT TO ADJACENT UNDERBAR PIECE
 - MOUNTING OPTIONS ALLOW FOR FLEXIBLE INSTALLATION OPTIONS TO REMOVE BACK OR FRONT AND BACK LEGS FOR A CLEAN INSTALLATION
- PLUMBING
 - 1-7/8" DRAIN WITH BASKET
 - 1-1/2" NPS DRAIN CONNECTION
- NSF CERTIFIED



PERFORATED DUMP BASKET
(INCLUDED)

ACCESSORIES	DESCRIPTION
PBF-4SM2-6LF	HEAVY DUTY FAUCET
PBF-W2-6LF	ECONOMY FAUCET
PB-WL-36	FLEXIBLE SHALLOW MOUNT FAUCET HOSES
UBSS-18-L	SLIM-LINE LEFT HAND SIDE SPLASH
UBSS-18-R	SLIM-LINE RIGHT HAND SIDE SPLASH
UBBSS-12	BLENDER STATION SHELF
UBDSB-1006	REPLACEMENT PERFORATED DUMP BASKET

DUMP SINK - 21" WIDTH

MODEL #	SIZE (LXWXH)	WT. (LBS)
UBDS-2112	12"X21"X32-1/2"	38

DETAILED SPECIFICATIONS

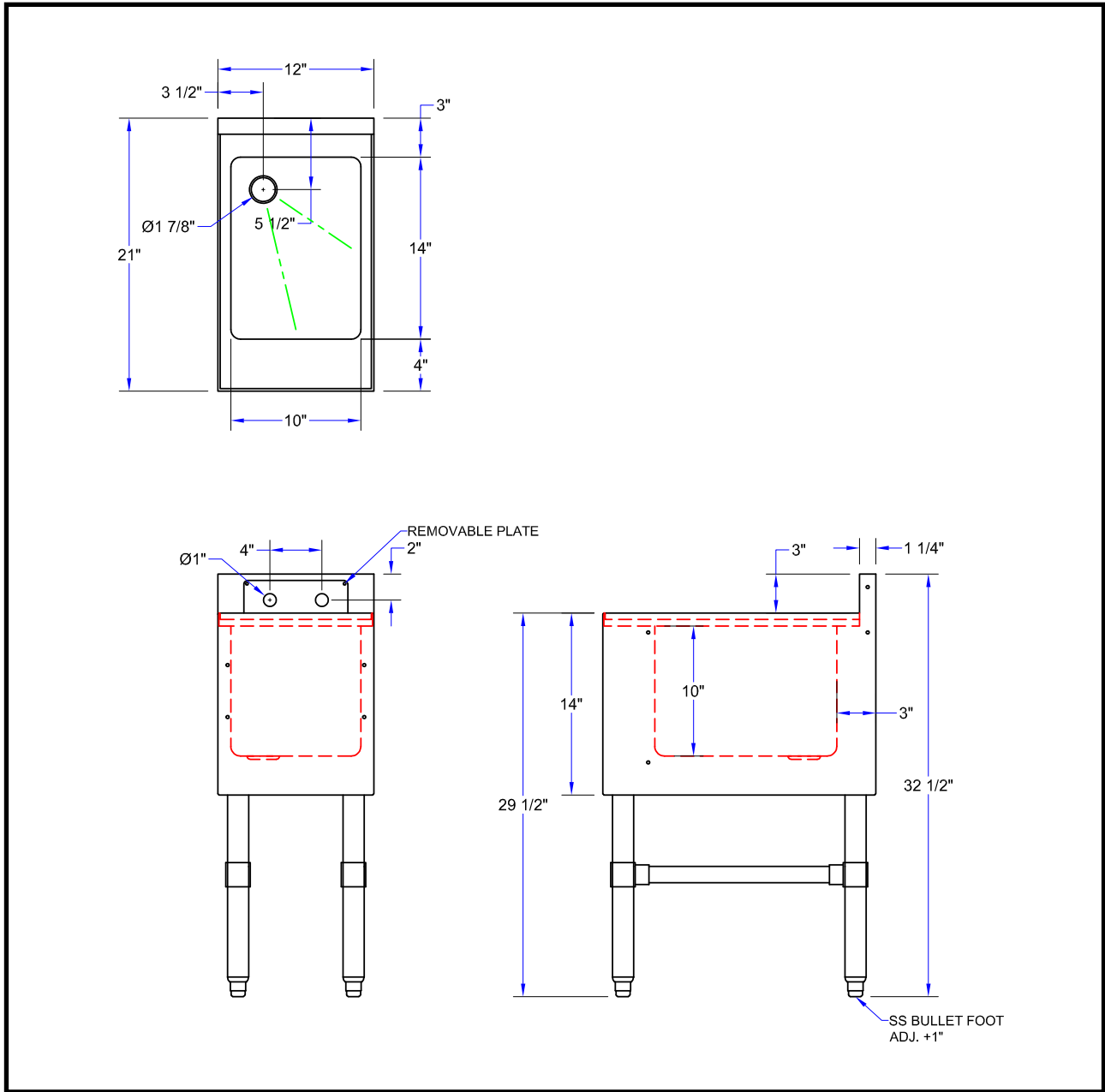

DUMP SINK - 21" WIDTH

MODEL #	SIZE (LXWXH)	WT. (LBS)
UBDS-2112	12"X21"X32-1/2"	38

SOME UNITS SHIP UNASSEMBLED FOR REDUCED SHIPPING COST. ALL DIMENSIONS ARE TYPICAL. TOLERANCE +/- .500"
 John Boos & Co. is constantly engaged in a program of improving products and therefore reserves the right to change specifications without prior notice.



Boos
lock

AQ AutoQuotes

3601 S. Banker St. • Effingham, IL 62401 • quotes@johnboos.com

www.johnboos.com

061621

19