



# BEVERAGE-AIR

Project: _____	AIA#
Item: _____	
Location: _____	SIS#
Approved: _____	

## HORIZON BOTTOM MOUNT REACH-IN

### HBF23HC Solid Door Reach-In Freezer

Hydrocarbon Series

**MODEL:**  
HBF23HC-1

**HBF23HC BOTTOM MOUNT REACH-IN FREEZER**



**5 Year Parts/Labor Warranty Available**  
**7 Year Compressor Warranty**

#### CABINET CONSTRUCTION

- Stainless steel front, side, and grille (galvanized back & bottom)
- Stainless steel interior
- LED lighting
- Full electronic control with one-touch defrost
- Expansion valve technology
- One-piece grille allow easy removal/installation for preventative maintenance
- Door lock (solid doors only)
- Self closing door with 120° stay open feature
- Spring-loaded style hinges
- Plug-in magnetic door gaskets
- Three (3) heavy duty epoxy coated wire shelves
- 6" Casters with two (2) brakes

#### OPTIONS & ACCESSORIES

- 3 Year parts/labor standard, additional 2 year warranty available
- Stainless steel universal tray slide pair, 1 tray slide set for (1) 18" x 26" or (2) 14" x 18" pans (AC)
- 3" Casters or 6" legs
- Epoxy shelves
- Shelf clips
- Remote option\* (see note on back page)

#### REFRIGERATION SYSTEM

- Uses environmentally friendly, energy efficient R290 refrigerant, and meets all regulatory requirements for CARB, SNAP, DOE & more
- Hot gas condensate evaporator
- Adaptive defrost
- Epoxy coated evaporator coil
- Freezer capable of maintaining product temperature down to -10°F



Please verify qualifying units by visiting:  
[www.energystar.gov/cfs](http://www.energystar.gov/cfs)

3779 Champion Blvd., Winston-Salem, NC 27105  
1-888-845-9800 Fax: 1-336-245-6453  
Beverage-Air.com Sales@bevair.com



# BEVERAGE-AIR

MODEL	HBF23HC-1
<b>EXTERNAL DIMENSIONAL DATA</b>	
Width Overall	27 ¼"
Depth Overall with Handle	33 ¾"
Height Overall with Casters	84 ⅞"
Number of Doors	1
Depth with Door Open 90°	57 ½"
Door Opening (in)	24 ⅞" x 52 ½"
<b>INTERNAL DIMENSIONAL DATA</b>	
NET Capacity (cubic ft.)	23.32
Internal Width Overall (in)	24 ¼"
Internal Depth Overall (in)	28 ½"
Internal Height Overall (in)	61 ¾"
Internal Height Useable (in)	55"
Number of Shelves	3
<b>ELECTRICAL DATA</b>	
Full Load Amperes 115/60/1	6.34
<b>REFRIGERATION DATA</b>	
Horsepower	¾
Capacity (BTU/Hr)	2097
Heat Rejection (BTU/Hr)	3145
Charge (lbs/grams/ounce)	0.2094 / 95 / 3.35
<b>SHIPPING DATA</b>	
Gross Weight - Crated	412 lbs
Height - Crated	85"
Width - Crated	31"
Depth - Crated	37"

NOTE: Remote units are field wired and come with 6" legs.  
Refrigerant must be specified at time of order.

## Bottom Mount Reach-In Freezer Model: HBF23HC-1

### Model Views

Required Clearance: Bottom & Rear 3"

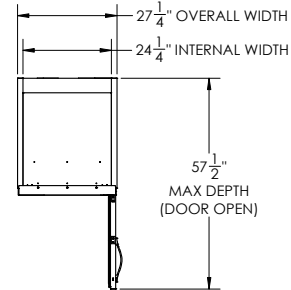

### PLAN VIEW

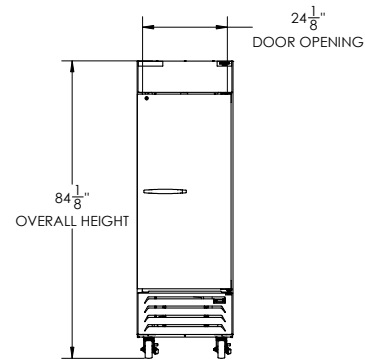

### ELEVATION VIEW

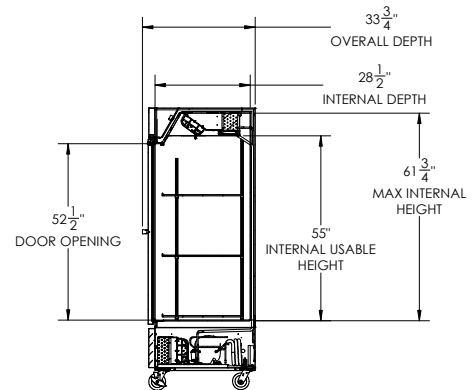

### SIDE VIEW

### ELECTRICAL CONNECTION



115/60/1  
NEMA 5-15P

Unit pre-wired at factory  
and include 8' long cord  
and plug set.

