

SHALLOW DEPTH BASE MODEL SANDWICH UNIT

MODEL: RA60SN8-D

Natural Refrigerant R-290 Model

60" Shallow Depth Base Model Sandwich Unit with Drawers

Heavy gauge #300 Series stainless steel top, stainless steel front and end panels, galvanized steel rear and grill and aluminum interior.



Options and Accessories

(upcharge and lead times may apply)

Stainless steel interior	Condensing unit left (standard on right)
Stainless steel back	Door & drawer locks
Stainless steel shelves	Pan Slides
Additional epoxy coated steel shelves	Front Breathing
Overshelves (single or double)	Adjustable legs
Drawer in lieu of door section above the condensing unit*	

Consult factory for other model configurations, options and accessories.

*Drawer section above condensing unit holds (4) 6 x 6 2/3 x 6 pan.

TWO TIER (larger section): (1) 12x20x6 pans per drawer

TWO NARROW: (4) 6 x 6 2/3 x 6 pan per drawer



Toll-Free: 800-523-7138
Phone: 215-244-1400
Fax: 215-244-9579

539 Dunksferry Road
Bensalem, PA 19020
www.continentalrefrigerator.com

Project Name:

Model Specified:

Location:

Item No: Quantity:

AIA #: SIS #:

Standard Model Features

REFRIGERATION SYSTEM

- Performance rated refrigeration system
- Natural Refrigerant R-290 Model
- Unique forced air design utilizes fans (approx. every 12") across the entire back of unit for even distribution of cold
- Automatic, hot gas condensate evaporator
- Non-corrosive, plasticized fin evaporator coil
- Easily serviceable, slide out condensing unit
- Expansion valve system

CABINET ARCHITECTURE

- 2" non-CFC polyurethane foam insulation
- Smooth, polished chrome door handles
- Spring loaded, self closing doors
- Magnetic snap in Santoprene™ door gaskets
- Heavy duty, epoxy coated steel shelf
- Completely enclosed, vented and removable rear and side grills
- 5" casters

MODEL FEATURES

- Electronic control, off cycle defrost
- Refrigerated section with door above the condensing unit
- Field rehingeable doors

¹ R-290 refrigerant meets all federal and state regulatory requirements.

NOTE: Models come standard with a door over the condensing unit. A drawer over the condensing unit is an option.

APPROVAL:

Model Specifications

DIMENSIONAL DATA

Net Capacity	15.2 cu. ft. (430 cu l)
Width, Overall	60 inches (1524 mm)
Depth, Overall (including handles & bumpers)	30 inches (764 mm)
Height, Overall (including 5" casters)	42 inches (1067 mm)
Shelf Area	0 Sq ft. (0 sq m)
Number of Shelves	0
Number of Doors	Full 0 Half 1
Interior Depth	24 inches (610 mm)
Interior Height	12.5 inches (318 mm)
Interior Height (above condenser)	12.5 inches (318 mm)
Interior Width	17 inches (432 mm)

REFRIGERANT DATA

Condensing Unit Size	1/3+ H.P.
Capacity	2300 (BTU per hour)*

ELECTRICAL DATA

Voltage (International)	115-60-1 (220-50-1)
Total Amps (International)	5.8 (3.9)
Defrost Amps	
10 ft. Cord/Plug [attached] (International)	Yes (No)

SHIPPING DATA

Weight (pounds)	340 lbs. 154 kg
Height - Crated	43.75 in. (1111 mm)
Width - Crated	62 in. (1575 mm)
Depth - Crated	47 in. (1194 mm)

DRAWER PAN CONFIGURATIONS

TWO TIER (larger section): (1) 12x20x6 pans per drawer
TWO NARROW: (4) 6 x 6 2/3 x 6 pan per drawer

* Rating @ +20°F evaporator, 120°F ambient
Figures in parentheses reflect metric equivalents rounded to the nearest whole unit.



www.continentalrefrigerator.com



© Copyright 2023. Continental Refrigerator.
A Division of National Refrigeration & Air Conditioning Products, Inc.

Model Plan Views

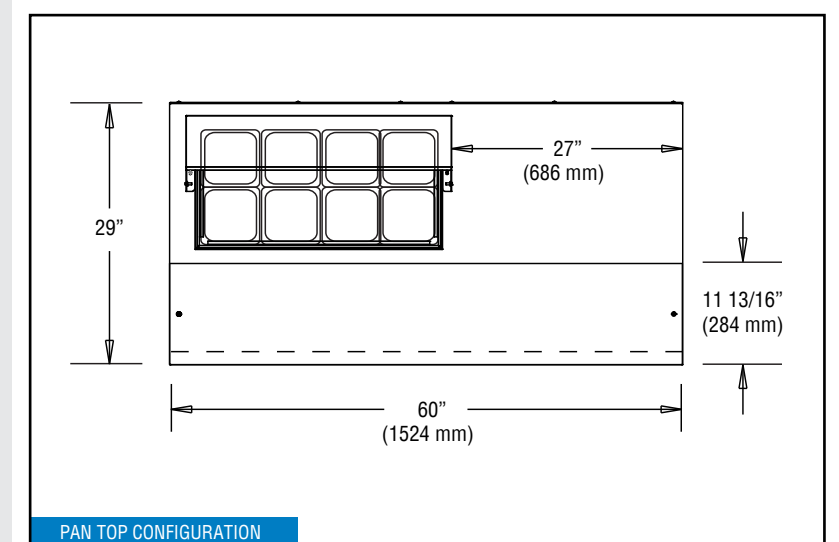
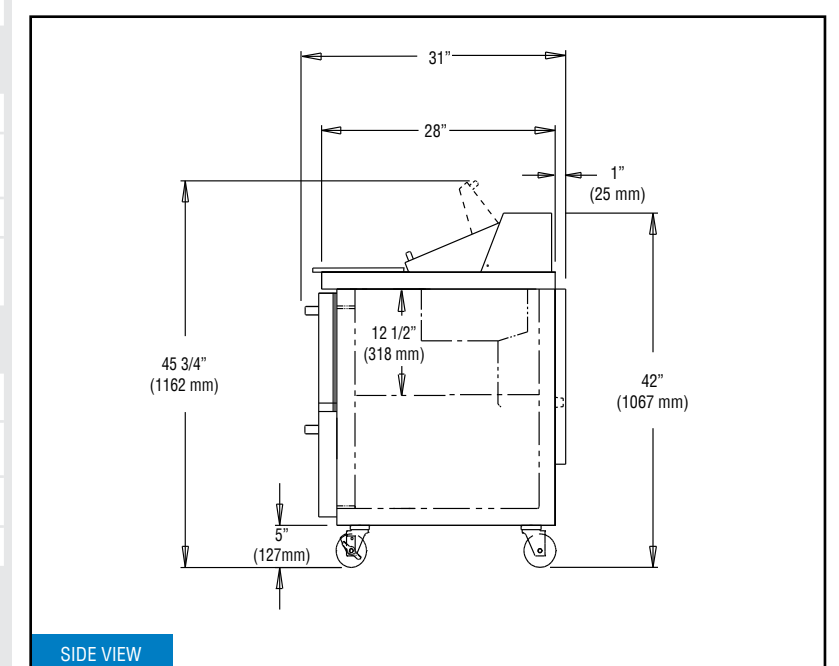
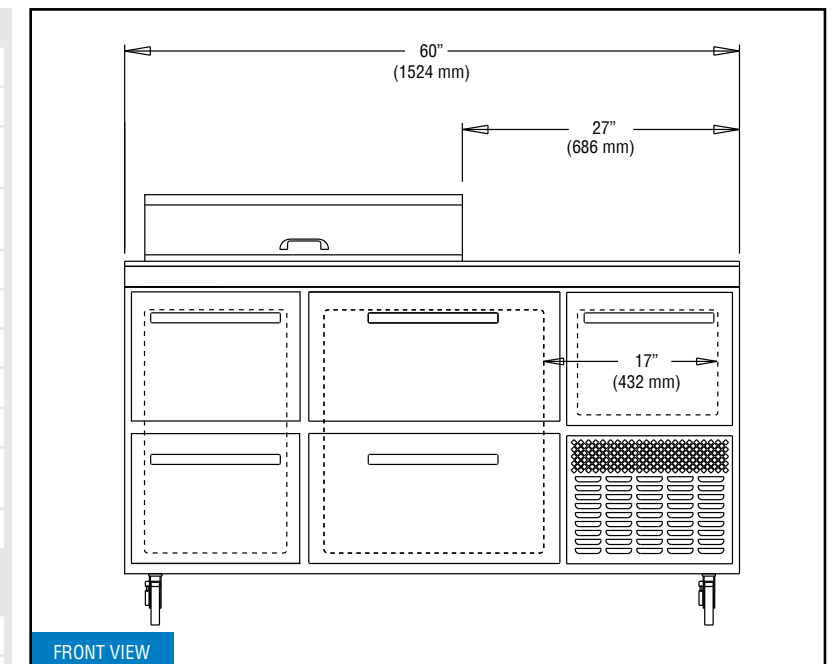

Due to our continued efforts in developing innovative products, specifications subject to change without notice.

REVISED: 8/11/23