

MULTICOOKER 64 GALLON ELECTRIC COOK AND CHILL PROCESS LINE



- UCPMDE2-64L - Automatic cooker (C&C line version)
- UBAVR64DX / UBAVR64SX- Mobile chilling vat
- UBACC1010 - Insulated trolley (2 Units)

UCPMDE2-64L

General Functional Features

- Heating by means of alluminum casted elements directly in contact with the vessel bottom, controlled by electronic board with automatic activation of minimum 2 °C before the SETPOINT and interruption of heating in case of minimum water level. Baskets lifting and tilting automatically (even with closed lid) stopping in dripping position and removable for cleaning operations. Automatic filling and refilling of water in the vat. Overflow device and system to make starch skimming easier. Front discharge valve in stainless-steel, 2 inc., with insulating handle.
- Optional: Removable shower head (cold water) to make cleaning operations easier. Electronic control by means of multifunctional keyboard with Touch Screen 7" and easy and clear messages
- Electric socket for connection to UBAVRDX.. / UBAVRSX.. (Do not use for other purpose)
- USB connection to download HACCP data, update the software and load cooking programs
- Ability to interrogate the machine using communication protocol MODBUS over RS485 serial interface
- Connection for power economizer

Panel Board Functions

- ON/OFF switch
- Resistive 7" Touch Screen
- Keys for moving basket
- Selection of 2 different cooking modes, with working temperature setting or min./max. heating
- Cooking type and time setting
- Cooking in "Manual" mode
- Cooking in "Program" mode
- Creating and editing cooking programs, setting, type of cooking; cooking parameters (temperature and time), and possibility to insert text messages
- Automatic vat filling with level maintenance
- Function starch skimming
- Delayed cooking setting with date, time, and programming cycle
- Language settings Touch Screen
- Input of different units of measurement (° C/° F; Liters/gallons; etc.)

Display/Signal

- Display type of cooking, temperature probes used and set temperature
- Heating operating visual alarm
- Time to end of cycle display
- Water level insufficient (heating does not activate)
- Automatic basket lifting (end of cooking) visual alarm with 10 seconds flashing notice on the Touch Screen
- Thermostat intervention safety signaling
- Self-diagnostics

Safety System

- Emergency button
- Heating interruption due to insufficient amount of water in vat
- Blocking of heating for overtemperature of the heating elements

UBAVR64DX / UBAVR64SX

Functional Features General

- Lifting up and down of the basket inside the cooling tank with electric tilting
- Forced water activation by means of dedicated pump, operating only with baskets in working position
- Flow agitation valve filling and exchange vat water by means of ball valve
- Filling and recirculation of water in the vat by ball valve
- Overflow device and discharge valve in stainless-steel, 2 inc., with insulating handle

Panel Board Functions

- ON/OFF switch
- Basket tilting and return
- ON/OFF switch agitation pump
- Flow agitation regulation

Safety System

- Thermal protection for agitation pump (light alarm)

OPTIONS & ACCESSORIES AT ADDITIONAL COST

- UCADE0020 - CLEANING SHOWER

STANDARD CONSTRUCTION SPECIFICATIONS

UCPMDE2-64L

Cooking vessel in stainless steel AISI 316 (thickness 30/10). Perforated basket in stainless steel AISI 316 (thickness 15/10) with electric tilting
Balanced lid in stainless steel AISI 304 (thickness 10/10)
Supporting structure in stainless steel AISI 304 (thickness 20-30/10)
Heat insulation guaranteed by panels in thick glass fiber
Outer cover in stainless steel AISI 304, fine satin finish (thickness 10/10)
Adjustable feet in stainless steel AISI 304 to ensure levelling
Protection level IPX5

UBAVR64DX / UBAVR64SX

Chilling tank in AISI 316

Perforated basket in stainless steel AISI 316 (thickness 15/10) and removable for cleaning operations
Supporting structure in stainless steel AISI 304 (thickness 20-30/10)
External panels in AISI 304 fine satin finish
Pivoting wheels, 2 with brakes

UBACC1010 (2 Units)

Entirely made of AISI 304 stainless steel
Insulated basins, pressed with rayed edges and with a drain equipped with ball wash-out valve
Dimensions suitable for GN 1/1 h.200 Containers
Shaped lower shelf
Rubber buffers
4 Pivoting wheels, 2 of them with brakes



Approval Notes: _____

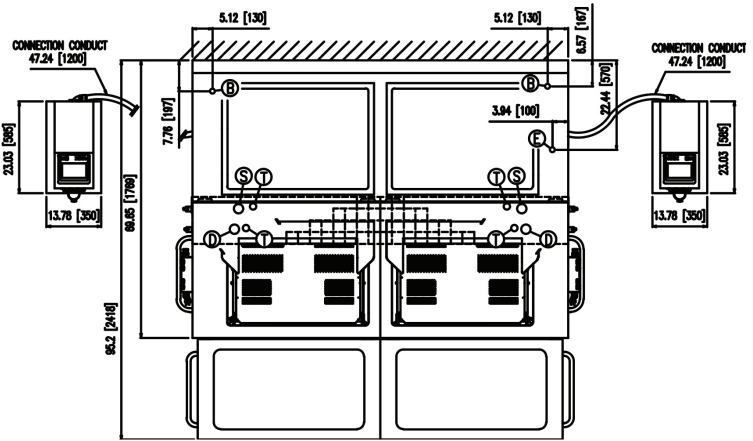
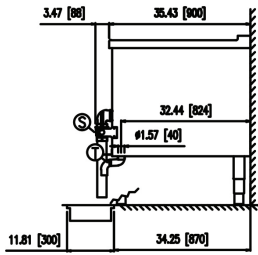
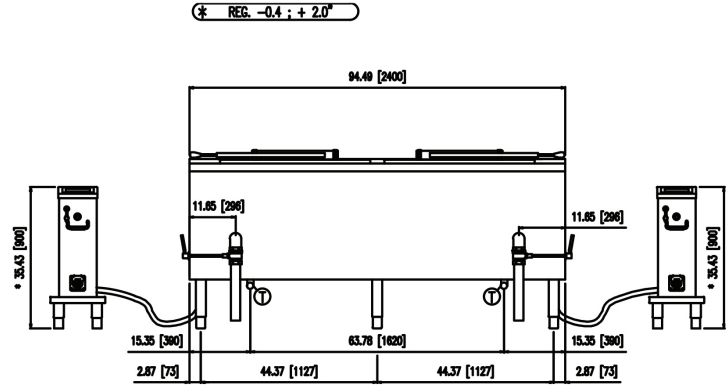
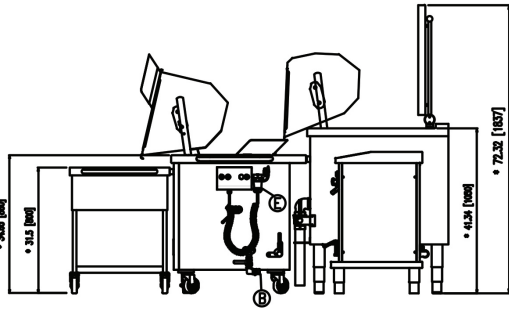

TECHNICAL SPECIFICATIONS

MODEL	DIMENSIONS						WEIGHT	CAPACITY	NUMBER OF BASKETS
	WIDTH	DEPTH	HEIGHT	VESSEL WIDTH	VESSEL DEPTH	VESSEL HEIGHT			
UCPMDE2-64L	94.49"	35.43"	35.43"	35.43"	25.20"	16.54"	893 lb	2 × 64 gal	2
UBAVR64DX / UBAVR64SX	39.37"	35.28"	38.58"	27.56"	25.20"	16.54"	386 lb	48 gal	1
UBACC1010 (2 Units)	31.50"	25.20"	49.41"	37.80"	20.08"	8.66"	112 lb	3 GN1/1	-

MODEL	UTILITIES						
	OVERFLOW (T)	H2O DRAIN (D)	COLD WATER INLET (B)	WATER PRESSURE	STD VOLTAGE (E)	ELECTRIC POWER	CURRENT
UCPMDE2-64L	1.57"	2.00"	0.50"	25-50 PSI	3 PHASE 208V~ 60Hz	42.40 kW	50.80 A
					3 PHASE 220-240 V~ 60Hz	43.00 kW	51.40 A
UBAVR64DX / UBAVR64SX	1.57"	2.00"	0.80"	25-50 PSI	1 PHASE 220-240V~ 60Hz*	1.40 kW	-
UBACC1010 (2 Units)	-	-	-	-	-	-	-

* Connected to multicooker, not to main supply

**INTENDED FOR COMMERCIAL USE ONLY.
NOT FOR HOUSEHOLD USE.**

