

**ELECTRICAL**

SEE PAGE TWO FOR DOUBLE CONTROL PANEL SPECS

**BUILT-IN FOOD WARMERS**

MOD-500TDM/AF

UNIT IS SHIPPED THREE PHASE AND IS FIELD CONVERTIBLE TO SINGLE PHASE.

MODEL	VOLTS	WATTS	AMPS PER LINE 3 PHASE			AMPS SINGLE PHASE	FIELD WIRING GAUGE		TEMP. RATING
			L1	L2	L3		3 PHASE	1 PHASE	
MOD-500TDM/AF	208	6200	19.5	14.6	14.6	29.8	10	8	90°C
MOD-500TDM/AF	240	8250	22.1	16.9	16.9	34.4	8	8	90°C

**CUTOUT DETAILS**

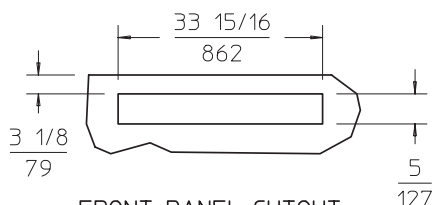
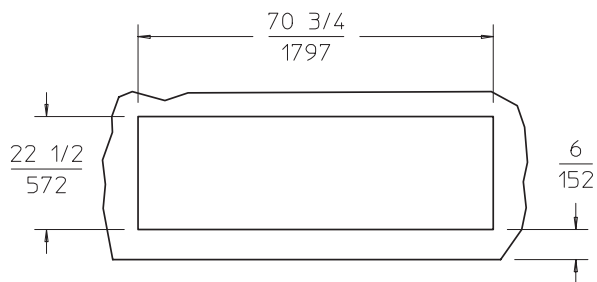

FRONT PANEL CUTOUT  
SINGLE CONTROL PANEL

**PRODUCT DIMENSIONS**

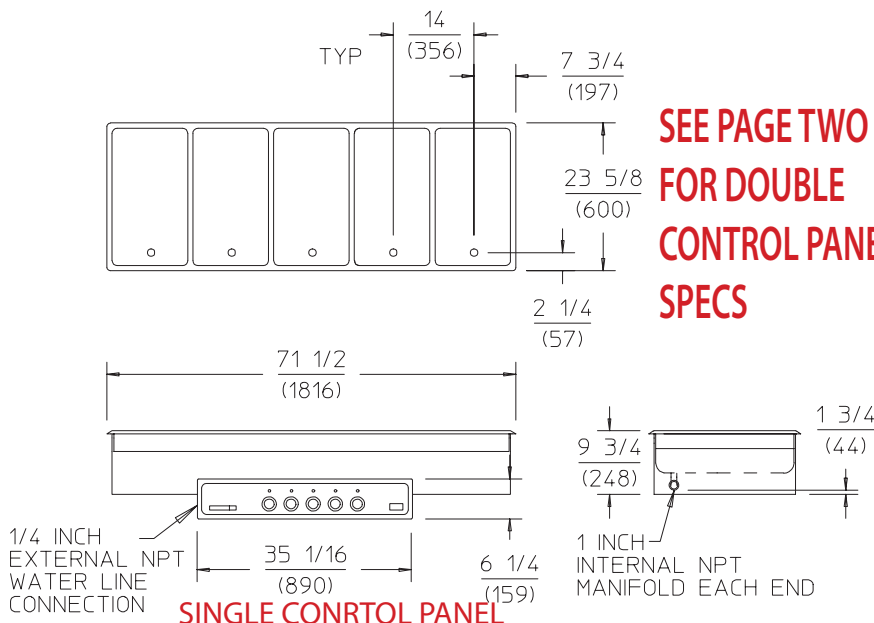

SEE PAGE TWO FOR DOUBLE CONTROL PANEL SPECS

**CLEARANCES**

MINIMUM CLEARANCE REQUIRED UNIT TO THE NEAREST SURFACE			
BACK	SIDE	BOTTOM	FRONT
1 (25)	1 (25)	6 3/4 (171)	6 (152)

**INSTALLATION INSTRUCTIONS**

INSTALLER MUST MEET CONDITIONS OF ACCEPTABILITY OUTLINED BELOW UPON INSTALLATION:

- Required installation clearances:  
Wooden and Metal Installation: DO NOT install closer than 6 inches to front wall, 1 inch to back and side walls, and 6 3/4 inches to surface below the unit. If the control box is located below the unit, the front clearance may be 1 inch.
- Unit shall be accessible for servicing from the bottom.
- If storage is to be used underneath the unit, it is recommended that a baffle be placed 8 1/2 inches below the unit to avoid contact with elevated temperatures.
- For water and waste connections: This appliance is to be installed to comply with the applicable federal, state, or local plumbing codes.

TO FABRICATE:

- Lay out cutout dimensions on countertop and front apron.
- Lay out and fabricate control panel holes in counter apron using the control box as a template.
- Cut out holes (Note: "stiffening" around perimeter of countertop cutout is not normally required).

TO INSTALL:

- IMPORTANT - DO NOT disconnect lead wires from the Master Control Panel when making installation.
- Tilt and pass Control Panel and electrical box through the countertop cutout, then through the apron cutout. Lower modular section into countertop cutout and position. RECOMMENDATION: Before final seating of modular section to countertop, apply a bead of silicone adhesive/sealant to the underside of gray gasket material supplied on the mounting flange.
  - From underneath, insert screwdriver into slots in Wellstock frame and twist ears outward (clockwise) as required to secure flange tightly to countertop.
  - Mount Control Box to apron cutout as shown in drawing.

- Mount Control Panel onto electrical box using the screws supplied.

TO PLUMB:

- A drain manifold complete with valve is supplied on all models except MOD100TD. Location of valve handle is at the discretion of the fabricator (see drawing).
- Connect 1" drain connection to suitable drain line.
- Connect 1/4"NPT water supply to Solenoid valve in Outlet Box. Note: Maximum pressure 120 psi, maximum temperature 120°F. A backflow preventor is incorporated in the unit, between the water fill solenoid and pan. Local codes may require an additional vacuum break device. (Not provided by Wells). Device must be installed in accordance with local codes and authorities having jurisdiction.

TO WIRE:

- Final connection is accomplished by bringing proper power supply leads (see 'WIRING REQUIREMENTS' label) through conduit knockout to terminal block supplied within the Master Control Panel. Check nameplates for voltage and phase.

NOTE: INSTALLATION MUST MEET LOCAL PLUMBING AND ELECTRICAL CODES.

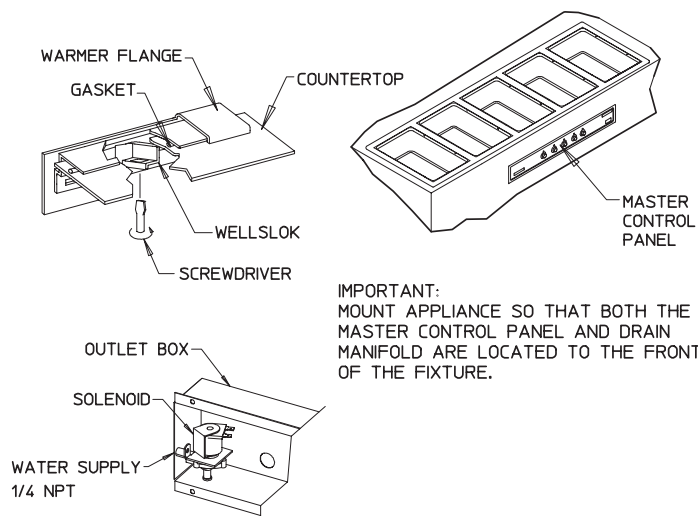

IMPORTANT: MOUNT APPLIANCE SO THAT BOTH THE MASTER CONTROL PANEL AND DRAIN MANIFOLD ARE LOCATED TO THE FRONT OF THE FIXTURE.

**INSTALLATION INSTRUCTIONS  
BUILT-IN FOOD WARMERS  
WITH AUTO WATER FILL  
MOD-500TDM/AF (2 CONTROL PANELS)**

**ELECTRICAL**

UNIT IS SHIPPED THREE PHASE AND IS FIELD CONVERTIBLE TO SINGLE PHASE.

MODEL	VOLTS	WATTS	AMPS PER LINE 3 PHASE			AMPS SINGLE PHASE	FIELD WIRING GAUGE		TEMP. RATING
			L1	L2	L3		3 PHASE	1 PHASE	
MOD-500TDM/AF	208	6200	19.5	14.6	14.6	29.8	10 AWG Cu	8 AWG Cu	90°C
MOD-500TDM/AF	240	8250	22.1	16.9	16.9	34.4	8 AWG Cu	8 AWG Cu	90°C

INCHES  
(MM)

**CUTOUT DETAILS**

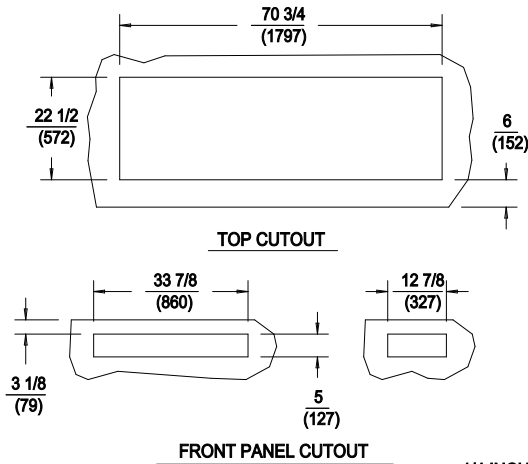

**PRODUCT DIMENSIONS**

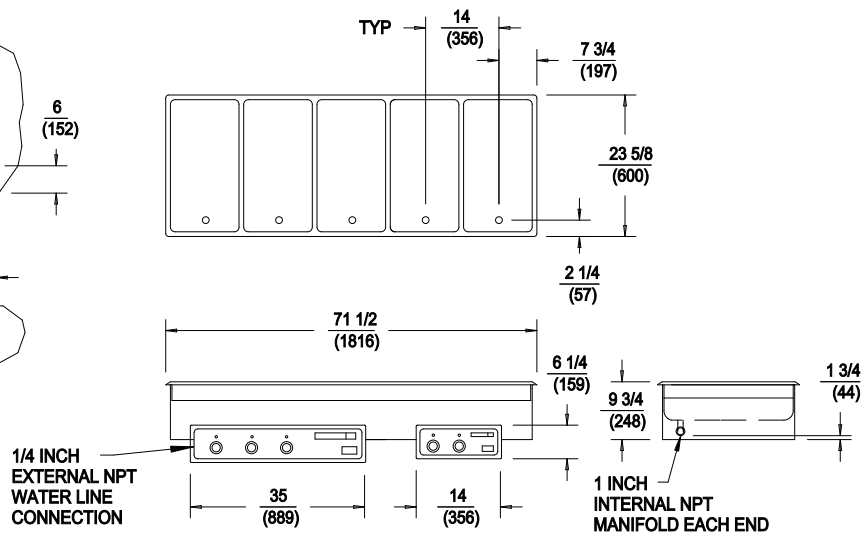

**CLEARANCES**

MINIMUM CLEARANCE REQUIRED FROM UNIT TO THE NEAREST SURFACE			
BACK	SIDE	BOTTOM	FRONT
1 (25)	1 (25)	6 3/4 (171)	6 (152)

**INSTALLATION INSTRUCTIONS**

**INSTALLER MUST MEET CONDITIONS OF ACCEPTABILITY OUTLINED BELOW UPON INSTALLATION:**

1. Required installation clearances:  
 Wooden and Metal Installation: DO NOT install closer than 6 inches to front wall, 1 inch to back and side walls, and 6 3/4 inches to surface below the unit. If the control box is located below the unit, the front clearance may be 1 inch.
2. Unit shall be accessible for servicing from the bottom.
3. If storage is to be used underneath the unit, it is recommended that a baffle be placed 8 1/2 inches below the unit to avoid contact with elevated temperatures.
4. For water and waste connections: This appliance is to be installed to comply with the applicable federal, state, or local plumbing codes.

**TO FABRICATE:**

1. Lay out cutout dimensions on countertop and front apron.
2. Lay out and fabricate control panel holes in counter apron using the control box as a template.
3. Cut out holes.

**TO INSTALL:**

- IMPORTANT - DO NOT** disconnect lead wires from the Master Control Panel when making installation.
1. Tilt and pass Control Panel and electrical box through the countertop cutout, then through the apron cutout. Lower modular section into countertop cutout and position. **RECOMMENDATION:** Before final seating of modular section to countertop, apply a bead of silicone adhesive/sealant to the underside of gray gasket material supplied on the mounting flange.
  2. From underneath, insert screwdriver into slots in Wellslock frame and twist ears outward (clockwise) as required to secure flange tightly to countertop.
  3. Mount Control Box to apron cutout as shown in drawing.

4. Mount Control Panel onto electrical box using the screws supplied.

**TO PLUMB:**

1. A drain manifold complete with valve is supplied on all models except MOD100TD. Location of valve handle is at the discretion of the fabricator (see drawing).
2. Connect 1" drain connection to suitable drain line.
3. Connect 1/4"NPT water supply to Solenoid valve in Outlet Box. Note: Maximum pressure 120 psi, maximum temperature 120°F. A backflow preventor is incorporated in the unit, between the water fill solenoid and pan. Local codes may require an additional vacuum break device. (Not provided by Wells). Device must be installed in accordance with local codes and authorities having jurisdiction.

**TO WIRE:**

1. Final connection is accomplished by bringing proper power supply leads (see 'WIRING REQUIREMENTS' label) through conduit knockout to terminal block supplied within the Master Control Panel. Check nameplates for voltage and phase.

**NOTE: INSTALLATION MUST MEET LOCAL PLUMBING AND ELECTRICAL CODES.**

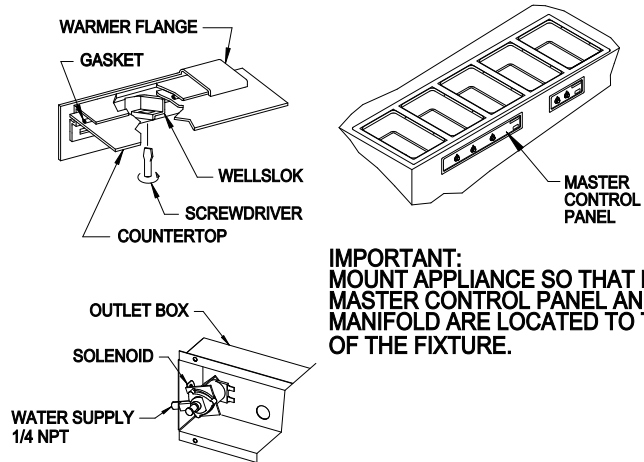

**IMPORTANT:** MOUNT APPLIANCE SO THAT BOTH THE MASTER CONTROL PANEL AND DRAIN MANIFOLD ARE LOCATED TO THE FRONT OF THE FIXTURE.