



Broaster® Pressure Fryer - 1800

Standard Features



- *Fast and productive* – specifically designed for high volume production, cooks up to 40 pieces of fresh bone-in chicken per load in as little as 10 minutes*.
- *Unique Pressure Activated Cover Locking Mechanism* – quick closing and opening single action sealing including a pressure-activated cover locking mechanism for safety and ease of use.
- *Proven round cooking well design* – engineered for more uniform heat distribution, durability, and efficiency; no cold spots or corners. Large capacity provides more room for product, minimizes sticking, and produces delicious, superior quality food.
- *Fully Welded Cooking Well* – made from durable 300 Series Stainless Steel.
- *Easy to operate* – SmartTouch Touch Screen Controllers feature a large 7" VGA full color touch screen with easy to navigate tab menu. A library of various menu items are included for quick and easy preparation.
- *Unique Auto Comp™ feature* – automatically adjusts cooking time to accommodate for varying sizes and temperatures of loads.
- *Automatic cook cycle counter* – monitors production between filtering.
- *Built-in filter system* – provides quick, easy, and safe cooking oil filtration; no heated fittings to disconnect.

* Cooktime varies with weight of product.



TESTED TO
ANSI/UL 197 10th Edition & ASNI/UL 1889 – C22.2 No. 109-M1981
ANSI / NSF 4

Specifications

Primary construction is of stainless steel built on powder-coated steel frame with chrome-plated front leveling feet. Rear legs are fitted with casters.

Round cooking well with 42 pound cooking oil capacity operates between 12-14 psi gauge pressure at temperatures up to 375° F.

Triple-redundant safety system is featured consisting of chrome relief valve, stainless steel splash guard and single action patented cam lock cover system with pressure regulator interlock. Also has single action combined pressure regulator valve/remote timer control, drain valve interlock and pressure activated cover locking mechanism. All ensure operator convenience and safety.

SmartTouch Touch Screen controller provides a programmable library with preloaded menu items and an automatic cook-cycle counter. Auto-Comp feature automatically adjusts cooking time dependent on size and temperature of load. On-screen prompts assist users in operating and maintenance functions.

On-board integrated filtration system consists of easily accessible stainless steel filter tray assembly. Powered by a 1/3 horse-power motor coupled to 5 gallon-per-minute rotary gear displacement oil pump.

Equipment is covered by manufacturer's 1 year parts and labor warranty on all systems, additional 1 year on controller parts and 10 year repair warranty on cooking well.

Specifications subject to change without notice.

Broaster® Pressure Fryer – 1800

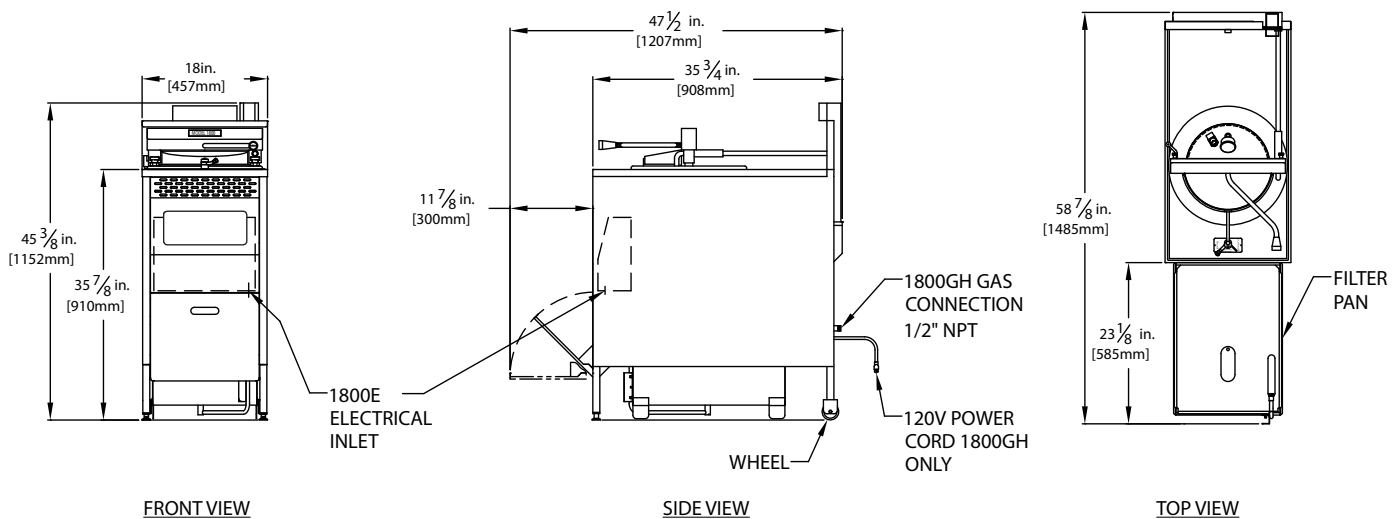

Dimensions

Model	Fresh Chicken Capacity	Cooking Oil Capacity	Operating Pressure	Overall Dimensions			Counter Height	Net/Ship Weight	Cubes
				W	D	H			
1800E	14 lbs./load	42 lbs.	12-14 P.S.I.	18"	35-3/4"	45-3/8"	37-5/8" (910 mm)	1800E 219/254 lbs.	20.6
1800GH	80 lbs./hour			(457 mm)	(908 mm)	(1152 mm)			

Energy Requirements

1800E 9.9kW Rated Heating Elements
 - 1 phase, 208 volt, 60 hz, 48 amps
 - 1 phase, 240 volt, 60 hz, 45 amps
 - 3 phase, 208 volt, 60 hz, 28 amps
 - 3 phase, 240 volt, 60 hz, 26 amps
 No cord/plug provided.

1800GH 65,000 BTU Rated Burner Assembly
 1 phase, 120 volt, 60 hz, Pump Motor Assembly
 Attached 6 ft. cord with plug

Main Burner Orifice

Natural Gas: #24 Drill

LP Gas: #41 Drill

Pilot Burner Orifice

Natural Gas: 0.018"

LP Gas: 0.011"

*Note: For proper operation at elevations above 2,000 feet, consult your authorized Broaster distributor for the correct orifice size.

Additional Features

- Durable, welded, tubular steel frame is powder-coated to resist corrosion.
- Stainless steel top and side panels offer durability and easy cleaning.
- Unique stainless steel basket with a ratchet-style removable basket handle allows easier unloading of product.

Accessories & Options Available

- Basic Accessory Kit
- Complete Start-up Accessory Kit

Specifications subject to change without notice.