



Project _____
 AIA # _____ SIS # _____
 Item # _____ Quantity _____ C.S.I. Section 114000

A-Series

**N-Width Reach-In Refrigerator Model
 32" Deep, Glass Door, Self-Contained**



STANDARD PRODUCT FEATURES

- Traulsen's Smart Control with LED Display
- Stainless Steel Exterior/Anodized Aluminum Interior
- Balanced, Self-Contained Refrigeration System Using R-450A
- Full or Half-Height Glass Door(s) with Lock(s)
- Anti-Condensate Door Perimeter Heater
- Self-Closing Doors with Stay Open Feature at 120 Degrees
- Standard Door Hinging: 132N = Left (other hings available)
- LED Lights with Exterior Switch
- Stainless Steel Breaker Caps
- Three Adjustable, Coated Wire Shelves Per Section, Supported on Shelf Pins (factory installed)
- Automatic Non-Electric Condensate Evaporator
- Magnetic Snap-In EZ-Clean Door Gaskets
- Thermostatic Expansion Valve Metering Device
- Stainless Steel One-Piece Louver Assembly
- 9' Cord & Plug Attached
- Set of (4) 6" High Adjustable Stainless Steel Legs

ACCESSORIES & OPTIONS

- Stainless Steel Finished Back with Rear Louvers
- #1 Type Trayslides to Accommodate either (1) 18" x 26" or (2) 14" x 18" Sheet Pans
- #4 Type Trayslides to Accommodate 18 to 19 Levels for 18" x 26" Pans
- Universal Type Trayslides to Accommodate Either (1) 18" x 26" or (2) 14" x 18", or (2) 12" x 20" Pans
- Additional Coated Wire or Optional Stainless Steel Shelves
- EZ-Change Interiors (#1, universals, universal heavy-duty trayslides & shelves)
- EZ-Open Foot Pedal (full-height doors only)
- Locking Hasps (padlocks supplied by others)
- Optional 220/50/1 or 208-230/115/60/1 Voltages
- Kool Klad Exterior Laminate Decor
- Set of (4) 4 1/8" or 6" High Casters in Lieu of Legs
- Other Support Options: 4 1/2" High Base or 6" High Kickplate (for use with standard legs)



This unit is listed to the applicable UL, CSA and NSF Standards by an approved NRTL. Consult the factory or unit's data plate for approval information.

AVAILABLE CONFIGURATIONS

A-Series Models

AHT132NUT-FHG
 AHT132NUT-HHG

Door(s)

Full Height Glass
 Half Height Glass

***Remote application available,
 see form TR35837 for details.**

- GUARANTEED FOR LIFE CAM-LIFT HINGES

Approved by _____ Date _____ Approved by _____ Date _____



A-Series

N-Width Reach-In Refrigerator Model
32" Deep, Glass Door, Self-Contained

MODEL

AHT132NUT-HHG

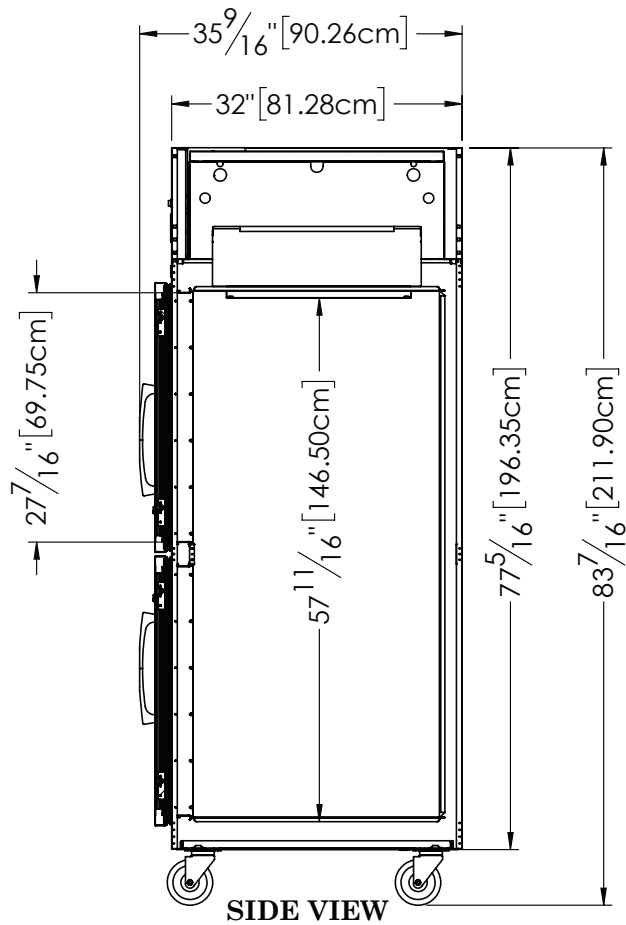
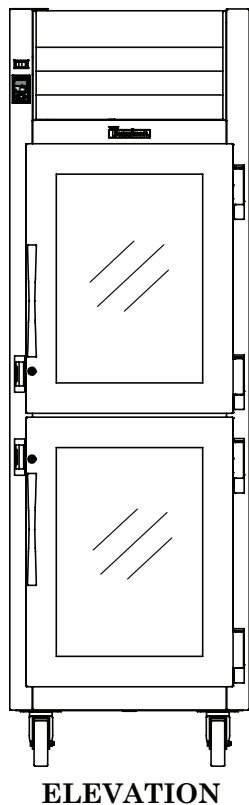
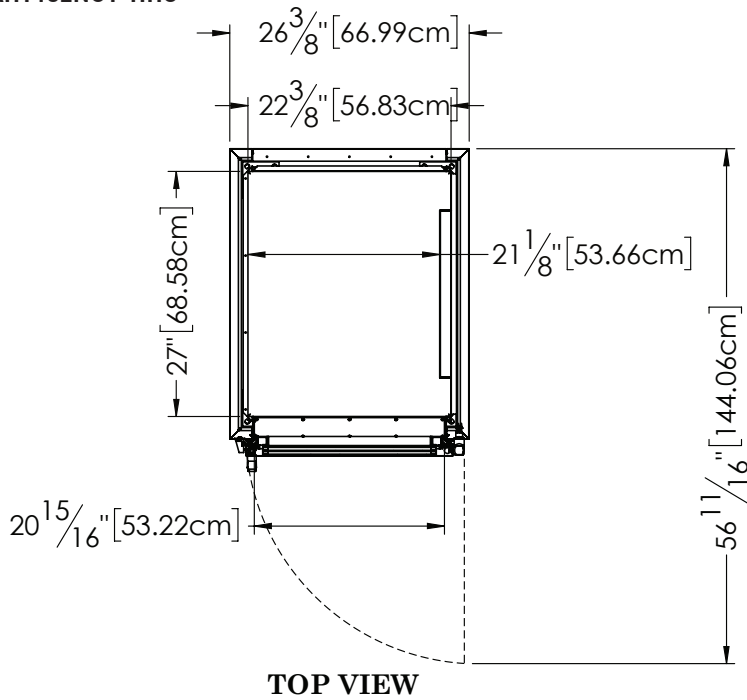

CAD and/or Revit Files Available

<https://traulsen.klccad.com/>



A-Series

N-Width Reach-In Refrigerator Model
32" Deep, Glass Door, Self-Contained

MODEL

AHT132NUT-FHG

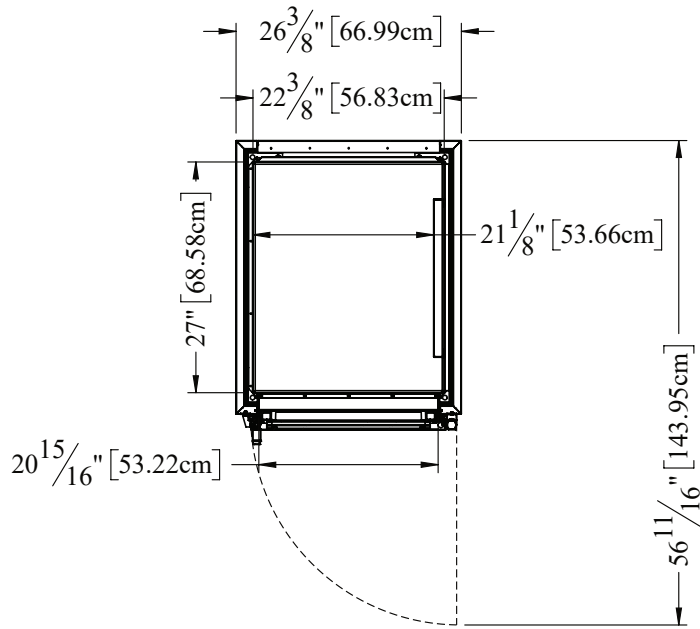

TOP VIEW

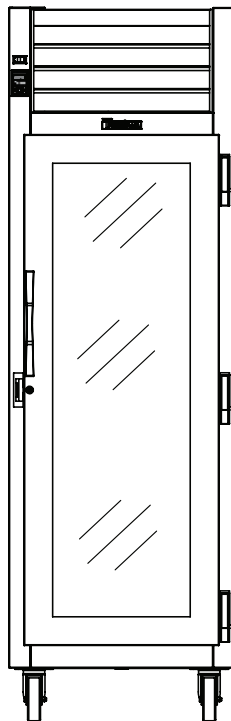

ELEVATION

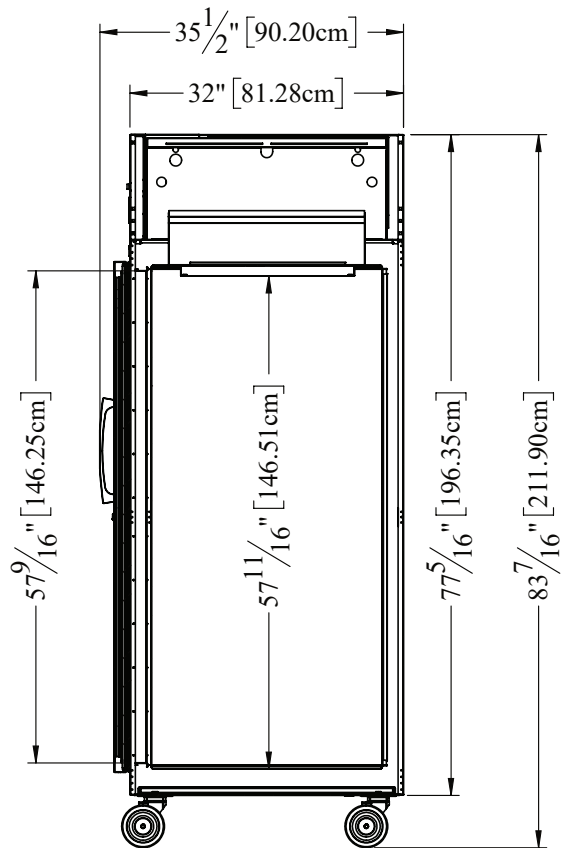

SIDE VIEW

CAD and/or Revit Files Available

<https://traulsen.klccad.com/>



MODEL

AHT132NUT-HHG
AHT132NUT-FHG

EQUIPMENT SPECIFICATIONS

MODELS	AHT132NUT
DIMENSIONAL DATA	
Net capacity cu. ft.	21.57 (610.8 cu l)
Length - overall in.	26 3/8" (67 cm)
Depth - overall in.	35 7/16" (90.3 cm)
Depth - over body in.	32" (81.3 cm)
Depth - door open 90° in.	56 11/16" (144 cm)
Clear door width in.	20 15/16" (53.2 cm)
Clear half-door height in.	27 7/16" (69.8 cm)
Clear full-door height in.	57 9/16" (146.3 cm)
Height - overall on 6" legs ²	83 7/16" (211.9 cm)
No. Standard Shelves	3
Shelf area sq. ft. ³	12.11 (1.13 sq. m)
ELECTRICAL DATA	
Voltage Plug	115/60/1 NEMA 5-15P
Full Load Amperes MDEC ⁴	6.7 2.87 kWh/Day
REFRIGERATION DATA	
Refrigerant	R-450A
Refrigerant Charge Amount oz.	14 (396.9 g)
BTU/HR H.P. ¹	2240 1/3 HP
SHIPPING DATA	
Length - Crated in.	48" (121.9 cm)
Width - Crated in.	42" (106.7 cm)
Height - Crated in.	85" (215.9 cm)
Volume - Crated cu. ft.	99.17 (2808.2 cu l)
Weight - Crated lbs.	402 (182.3 kg)

CONSTRUCTION, HARDWARE, INSULATION

The cabinet exterior front, one piece sides & louver assembly are made from heavy-gauge stainless steel. The interior is constructed of anodized aluminum. The exterior top & bottom are made from heavy-gauge galvanized steel. Included is a set of four adjustable 6" stainless steel legs.

Doors have removable plug cylinder locks & guaranteed for life gravity action, self-closing glide hinges that stay open at 120 degrees. An external switch is included to activate interior LED lighting. The gasket design simplifies cleaning & enhances longevity. Anti-condensate heater located behind each door. The unit has seamless, polished metal corners & vertical stainless steel handles. The cabinet is insulated with high density, non-CFC, foamed in place polyurethane.

SELF-CONTAINED REFRIGERATION SYSTEM

The unit uses a top-mounted, balanced system located behind the one piece louver assembly. The R450A refrigerant is environmentally friendly & non-flammable. It features a thermostatic expansion valve, air-cooled hermetic compressor, plenum effect blower coil, large, high humidity evaporator coil outside the food zone & a top-mounted non-electric condensate evaporator. Operating temperatures are 34-38°F. A 9' cord and plug are provided.

CONTROL

Traulsen's Smart Control features advanced control algorithms & sophisticated diagnostic capabilities to optimize performance. Utilizing Smart Sensors, it adapts the operation of the refrigeration system to a variety of environments & usage patterns. The Smart Control also offers a complete set of visual alarms designed to alert the user to critical events such as power outages or a prolonged door opening. In the event of an alarm, a dedicated Alarm LED will illuminate, informing the user of the critical event and duration.

INTERIOR

The interior includes three factory installed pin-mounted, full-width coated wire shelves per section with no large gaps. Each shelf can support up to 225 lbs. Factory installed optional trayslides may be purchased in combination with, or in lieu of these.

WARRANTY

Both a six year parts & labor warranty and a seven year compressor warranty (self-contained models only) are provided standard.

NOTES: Figures in parentheses reflect metric equivalents.

1. Based on a 90°F ambient and 20°F evaporator.
2. 12" Top clearance preferred for optimum performance & service access.
3. Area of standard shelf compliment only, does not include storage area of additional shelves or available on cabinet bottom.
4. MDEC = Maximum Daily Energy Consumption

When ordering please specify: Voltage, Hinging, and Options

Equipped with one NEMA 5-15P Plug



CONTINUED PRODUCT DEVELOPMENT MAY NECESSITATE SPECIFICATION CHANGES WITHOUT NOTICE.