

Elegance . . . the most petite GrandFlame

GRANDFLAME REF: GF-ELEGANCE



The most petite rotisserie in our GrandFlame line, the Elegance cooks with dramatic flames while providing a space-saving solution for small venues and those whose menu requires roasting only a few pieces at a time.

- All- stainless steel with brass trim & roof
- Available in Natural Gas and can be converted to propane
- 2 spits with separate motor
- Optional cabinet on casters with pull-out working surface

What can the various spits enable you to cook?: Any poultry from quail to a 20 lb turkey, steaks, roasts, leg of lamb, prime rib, fish, chicken breast, portobello mushrooms, halved squash or eggplant, pineapple, potatoes - almost anything you can think of roasting!

When it comes to rotisseries, Rotisol is your indispensable partner!

STANDARD FEATURES

- | | | | | |
|--|---|--|--|--|
| <input checked="" type="checkbox"/> All-Stainless Steel Finish with Brass or Chrome Trim | <input checked="" type="checkbox"/> 2 spits for cooking with individual motors | <input checked="" type="checkbox"/> 2 V-shaped non-piercing chicken spits | <input checked="" type="checkbox"/> Lightweight SS decorative roof | <input checked="" type="checkbox"/> Spit positions adjustable in depth |
| <input checked="" type="checkbox"/> Bottom drip pan with drain plug | <input checked="" type="checkbox"/> Doors are self-blocking and of tempered "K-glass" | <input checked="" type="checkbox"/> Removable inside panels for ease of cleaning | <input checked="" type="checkbox"/> Powerful halogen lamp | <input checked="" type="checkbox"/> 2 spit movers |

ACCESSORIES & OPTIONS

- | | | |
|---|--|--|
| <input type="checkbox"/> Base Cabinet with retractable table | <input type="checkbox"/> Prongless V-Spit | <input type="checkbox"/> Rectangular Basket Spit |
| <input type="checkbox"/> Heated Base Cabinet with retractable table | <input type="checkbox"/> Complete Chicken Spit (traditional style) | <input type="checkbox"/> Roast Clamp Spit |
| <input type="checkbox"/> Spit Racks - Wall-mounted or Wheeled | <input type="checkbox"/> Ham/Turkey Spit | <input type="checkbox"/> Lamb/Suckling Pig Spit |
| <input type="checkbox"/> Gloves, Foam Plus Cleaner | | |

CAPACITY

4 to 6 chickens

POWER

Natural Gas

Propane Gas



Rotisol-France, Inc 415 W. Walnut Street, Gardena, CA 90248 | Tel/ 800-651-5969 310-671-7254 | Fax/ (310) 671-8171

www.rotisolusa.com info@rotisolusa.com

SPECIFICATION ELEGANCE GAS

FRONT VIEW

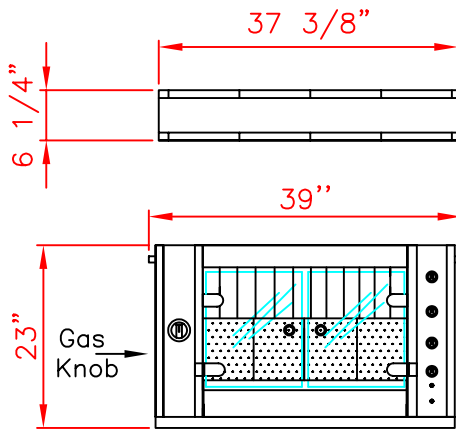

SIDE VIEW

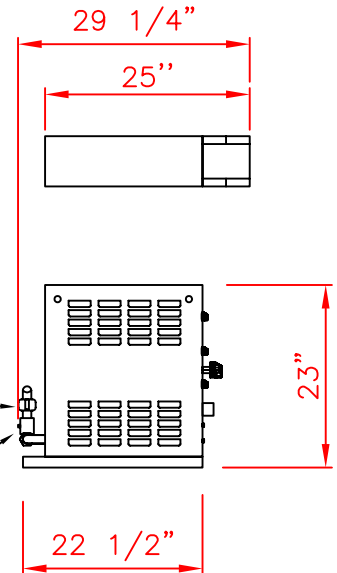

← **ROOF**
Optional →

Electrical Connection
220 Volts
Left side (rear)

Shut off valve
(3/4" pipe connection)
Right side (rear)

Master Switch

Regulator

TOP VIEW

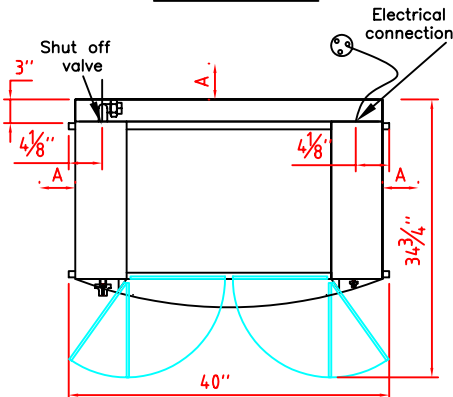

A :6" clearance between Gaz Rotisserie & wall

DIMENSION (inches)				GAS CONNECTION	
	WIDTH	HEIGHT	DEPTH	- pipe ; 3/4", non corrugated flexible quick disconnect recommended - Consumption : 28,000 Btu/h (natural) 25,000 Btu/h (propane) - Minimum pressure : 7" WC	
1-rotisserie	39	23	22 1/2	ELECTRICAL CONNECTION	
2-roof	37 3/8	6 1/4	25	- Standard : 750 W/ 220V/ 1 phase/ 3.5 Amps 1 Electrical cable : 78" length the plug is not provided	
1+2	39	29 1/4	29 1/4	WEIGHT	NOTE
VENTILATION REQUIREMENTS				- Roof : 40 Lbs - Rotisserie : 288 Lbs - Packing : 50 Lbs	- Nb of motors: 2 - Nb of burners: 1 - Nb of spits: 2 - Nb of glass doors: 2 - Nb of halogen lamps: 1
A type 1 hood is required. Hood and ventilation system could be installed and maintained in accordance with NFPA 96, and all relevant national and local codes. Solid-fuel cooking equipment must be vented separately from equipment that is not fired by solid-fuel. A minimum dimensions enclosure are as follows: 52" width , 42" Depth					

NOTE: Specifications, design and features are subject to change without notice.

WARRANTY CONDITIONS :

rotisol warrants its equipment to be free from defects in material and workmanship. the warranty covers parts for one year and labor for 6 months. repairs must be performed by an authorized service company and it is the responsibility of the customer to return the defective parts to rotisol france, inc. within 15 days(otherwise, the warranty will not be honored). the shipping charges for replacement parts, other than ground, will be at the customer's expense. this warranty does not cover glass door breakage and quartz or halogene lamp breakage, neither does it cover a mechanical parts. this warranty does not apply to damages by accident, incorrect line voltage, fire, water, or other acts or god.

GRANDFLAME ACCESSORIES

GRANDE FLAMME ACCESSORIES	PRODUCT	MODEL	Overall length	Usable length	Weight	Reference
 <p>Traditional Chicken Spit with prongs (2 singles and one double for 950 model, 2 singles and two doubles for 1350 model and 2 singles and 3 doubles for 1650 model)</p>	<ul style="list-style-type: none"> • Chicken • Quail • Family size • Chicken 	950/x	26 ¼"	21 ½"	1.9 lbs.	BP9
		1350/x	42"	37"	2.9 lbs.	BP13
		1650/x	53 ¾"	49"	4.6 lbs.	BP16
		GF975	27"	23"	1.9 lbs.	BP975
		GF1375	42 ¾"	39"	2.7 lbs.	BP1375
		GF1675	54 ½"	50"	4.7 lbs.	BP1675
 <p>Prongless chicken Spit</p>	<ul style="list-style-type: none"> • Chicken • Does not pierce the skin 	950/x	26 ¼"	21 ½"	1.1 lbs.	CUI9
		1350/x	42"	37"	1.7 lbs.	CUI13
		1650/x	53 ¾"	49"	2.3 lbs.	CUI16
		GF975	27"	21 ½"	2.0 lbs.	CUI975
		GF1375	42 ¾"	37"	1.9 lbs.	CUI1375
		GF1675	54 ½"	49"	2.1 lbs.	CUI1675
 <p>Turkey Spit with prongs (2 singles for 950 model, 2 singles and one double for 1350 model ; 2 singles and 2 doubles for 1650)</p>	<ul style="list-style-type: none"> • Whole Turkey • Ham 	950/x	26 ¼"	21 ½"	2.0 lbs.	BS9
		1350/x	42"	37"	3.3 lbs.	BS13
		1650/x	53 ¾"	49"	4.5 lbs.	BS16
		GF975	27"	23"	1.9 lbs.	BS975
		GF1375	42 ¾"	35"	3.3 lbs.	BS1375
		GF1675	54 ½"	46 ½"	4.6 lbs.	BS1675
 <p>Roast basket Spit (Max 5 ½" height)</p>	<ul style="list-style-type: none"> • Roasts • Fish • Turkey Breast • Small Prime Rib 	950/x	26 ¼"	21 ½"	4.2 lbs.	BRRO9
		1350/x	42"	37"	6.3 lbs.	BRRO13
		1650/x	53 ¾"	49"	7.5 lbs.	BRRO16
		GF975	27"	21"	4.3 lbs.	BRRO975
		GF1375	42 ¾"	36"	5.9 lbs.	BRRO1375
		GF1675	54 ½"	47"	7.3 lbs.	BRRO1675
 <p>Rectangular basket Spit (5" depth x 2 ½" height)</p>	<ul style="list-style-type: none"> • Small Parts • Chicken legs • Fish • Vegetables • Sausages 	950/x	26 ¼"	21 ½"	4.3 lbs.	BRC9
		1350/x	42"	37"	6.3 lbs.	BRC13
		1650/x	53 ¾"	49"	7.9 lbs.	BRC16
		GF975	27"	21"	4.3 lbs.	BRC975
		GF1375	42 ¾"	35"	6.3 lbs.	BRC1375
		GF1675	54 ½"	47"	7.5 lbs.	BRC1675
 <p>Lamb Spit (8 ½" Deep)</p>	<ul style="list-style-type: none"> • Lamb • Suckling pig • Large Prime Rib • Deboned turkey 	950/x	26 ¼"	21 ½"	6.4 lbs.	BA9
		1350/x	42"	37"	9.7 lbs.	BA13
		1650/x	53 ¾"	49"	12.1 lbs.	BA16
		GF975	27"	17"	6.4 lbs.	BA975
		GF1375	42 ¾"	32"	9.7 lbs.	BA1375
		GF1675	54 ½"	44"	12 lbs.	BA1675



ENVIRONMENT ACCESSORIES	PRODUCT	MODEL	Overall length	Weight	Reference
	<u>Stainless Steel Tray for Unspitting</u>	950/x & GF975	23"	lbs.	PID975
		1350/x & GF1375	38 ¾"		PID1375
		1650/x & GF1675	50 ½"		PID1675
	Stainless steel wall-mounted spit holder	any	30 ¼" W x 3" H With 5 hooks	4.5 lbs.	SMIB
	<u>Spit Rack for 10 spits in all stainless steel</u>	950/x & GF975	31 ¾" W x 19 7/8" D x 53 1/8" H	80 lbs.	RACK10 975
		1350/x & GF1375	47 1/4" W x 19 7/8" D x 53 1/8" H	110 lbs.	RACK10 1375
		1650/x & GF1675	59 1/4" W x 19 7/8" D x 53 1/8" H	140 lbs.	RACK10 1675
	<u>Plastic cover for 10-spit rack</u>	950/x & GF975	to fit rack	5 lbs.	BACHE10 975
		1350/x & GF1375	to fit rack	6.5 lbs.	BACHE10 1375
		1650/x & GF1675	to fit rack	10 lbs.	BACHE10 1675
	<u>Spit Rack for 20 spits in all stainless steel</u>	950/x & GF975	31 1/2" W x 31" D x 53 3/8" H	80 lbs.	RACK20 975
		1350/x & GF1375	47 1/2" W x 31" D x 53 3/8" H	110 lbs.	RACK20 1375
		1650/x & GF1675	59 1/8" W x 31" D x 53 3/8" H	140 lbs.	RACK20 1675
	<u>Plastic cover for 20-spit rack</u>	950/x & GF975	to fit rack	10 lbs.	BACHE20 975
		1350/x & GF1375	to fit rack	13 lbs.	BACHE20 1375
		1650/x & GF1675	to fit rack	19 lbs.	BACHE20 1675
	<u>Foam Plus cleaner (formerly "Hot & Foamy")</u> 1 case of 6 bottles	all	6 bottles of 32 ounces each	9.5 lbs.	0420
	<u>T&S Brass HG-4D-48K Sate-T-Link Gas Connector kit</u>	All gas units	¾" Connection, Coated, 48" Long – Furnished with Quick Disconnect, Street "EI" ball valve, Restraining Cable adj. for 3' to 5'	3 lbs.	0080
	<u>3 Finger with VaporGuard Quicklean Gloves</u>	all	BurnGuard™ 15" 3-Finger Gloves Poly-Cotton (insulation to 650 °F)	1 lbs.	GROT

