

Specification
ER10(1B)
Countertop Food Warmer



- Waterless design allow your convenient & safety Operation.
- No need water pan & water.
- Reduce operation & maintenance cost, unlike Traditional dry wells or steam table with water
- Stainless Steel Construction.
- Easy to clean.
- 6" deep open waterless pan.
- Individually controlled heating elements.
- Thermostatic heat controls and indicator lights.
- Limited manufacturers warranty .



NOTE: Dimensions and Specification are subject to change without notice

Specification
ER10(1B)
Countertop Food Warmer

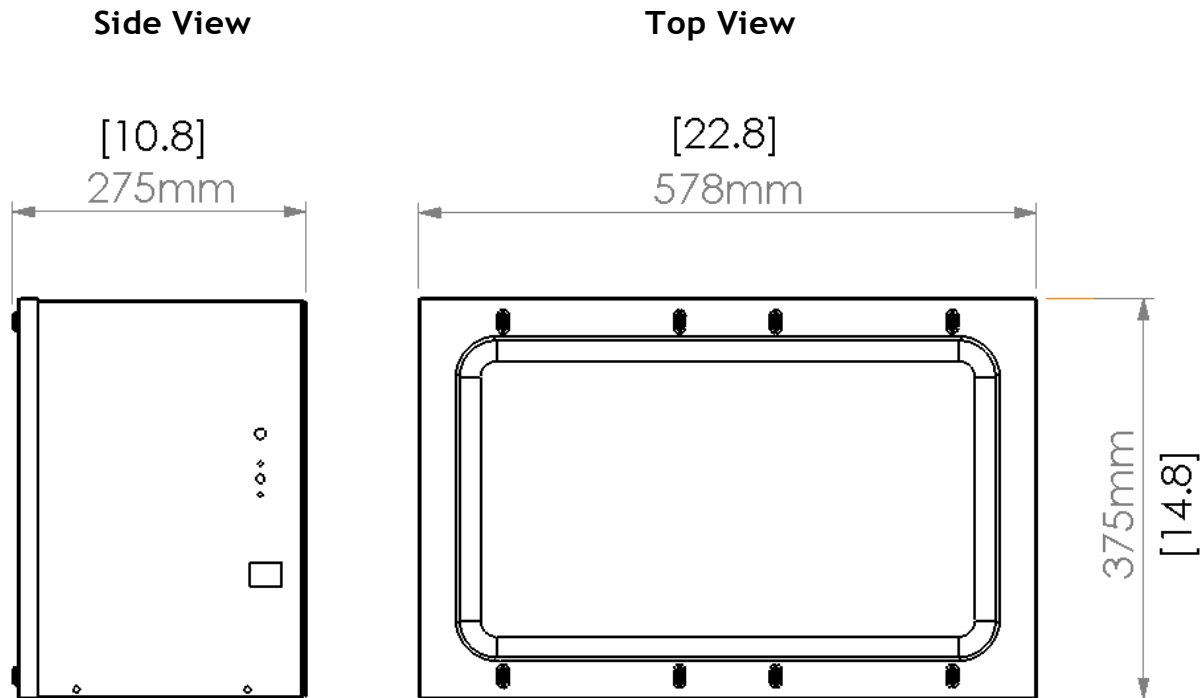

Pan Capacity 20" x 10" x 6"

Electrical 120 Volts, 4 Amps,60Hz

Power 550 Watts

Cord NEMA 5-15P

Net Weight 33 lbs(15 Kg)

Gross shipping weight 40 lbs(18 Kg)

Class 85

Dimensions 25.1" W x 16.9" D x 12.5" H

Package 26" W x 17" D x 13.5" H

Warranty 1 Year Manufactures limited Warranty