

A-1F BROILER / GRIDDLE COMBINATION

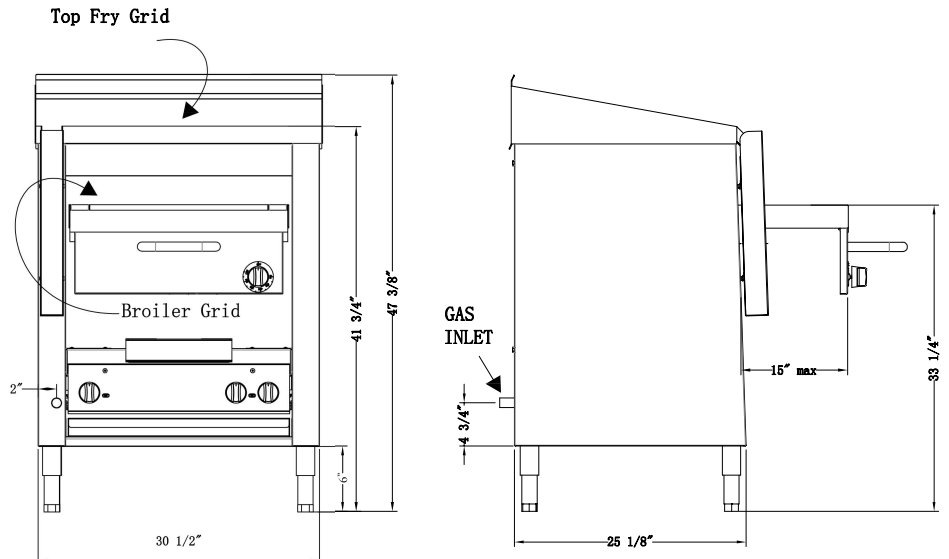

SPECIFICATIONS:

Overall Width:	31 1/4"
Overall Depth (body):	25"
Overall Height:	47 3/8"
Top Fry Grid Height:	41 3/4"
Broiler Grid Up:	30"
Broiler Grid Down:	26"
Legs (S/S) :	6"
Broiler Grid pulls out:	15"
Broiler Grid:	17 3/4" x 23 1/2"
Top Fry Grid:	22" x 31"
Gas Inlet:	3/4" pipe
Maximum BTU:	102,000
Crated Weight (approx):	500 lbs.

- Heavily insulated, all stainless steel body with stainless steel inner body lining and stainless steel removable side and back liners for easier cleaning
- All welded frame with stainless steel legs and adjustable feet
- Cast iron top burners with ceramic radiants
- Broiler griddle mechanism assembly removable for easier cleaning
- Broiler mechanism moves in and out with ease on our specially designed, heavy-duty ball bearing rollers for loading and unloading of product

PRODUCT SPECIFICATIONS:

BODY:	18 Gauge #304 Stainless Steel
INNER LINER:	24 Gauge #304 Stainless Steel
GRIDDLE PLATES:	Top -- 1/2" Highly Polished Steel Plate Bottom -- 5/8" Highly Polished Steel Plate
SPLASH:	14 Gauge #304 Stainless Steel
BURNERS:	Top -- Cast Iron w/ Ceramic Radiants Bottom -- Stainless Steel
DRIP PAN:	18 Gauge #304 Stainless Steel
VALVES:	Heavy Duty Brass
GAS INLET:	3/4" NPT
GAS PRESSURE:	4.0" Natural, 11.0" Propane (Inches Water Column)

Available Options:

- Casters (6" Locking)
- Grooved Grid plate
- Chromed Grid plate
- Charbroiled on top as sperate unit
- Castor & Legs extensions 2" Height

Gas Pressure Regulator is supplied and must be installed Combustible Locations: 6" Clearance sides and back Non-Combustible Locations Only: 0" Clearance sides and back Specify type of gas and altitude if over 2,000 feet

Connerton reserves the right, without notice, to make changes and revisions in product specifications, materials and design, which in our opinion will provide better performance, durability and efficiency.

